

EE4435 Fall 2001
Design Project 2
An Analog Voice Scrambler

Object

The object of this experiment is to design, implement, and test an analog voice scrambler. Such a circuit might be used for secure voice communications, e.g. over telephone lines or via short wave transmission.

Background

The telephone band is defined as the band from 300 Hz to 3000 Hz. Voice limited to this range is intelligible and the talker can be recognized by the listener. A method of scrambling a voice signal that has been limited to the telephone band is to invert the frequencies in the signal spectrum. That is, 300 Hz becomes 3000 Hz and vice versa. When speech is scrambled in this way, it is unintelligible unless a descrambler is used to restore the frequencies to their original values.

A possible speech scrambler circuit is diagrammed in Figure 1. The input signal is a voice signal from the output of a microphone preamplifier. A band-pass filter limits the bandwidth of the signal. The output of the filter is applied to a balanced modulator which multiplies the signal by the output signal from an oscillator. The output of the balanced modulator consists of two sidebands, a lower sideband and an upper sideband. A low-pass filter passes the lower sideband to the output, which is the scrambled speech signal.

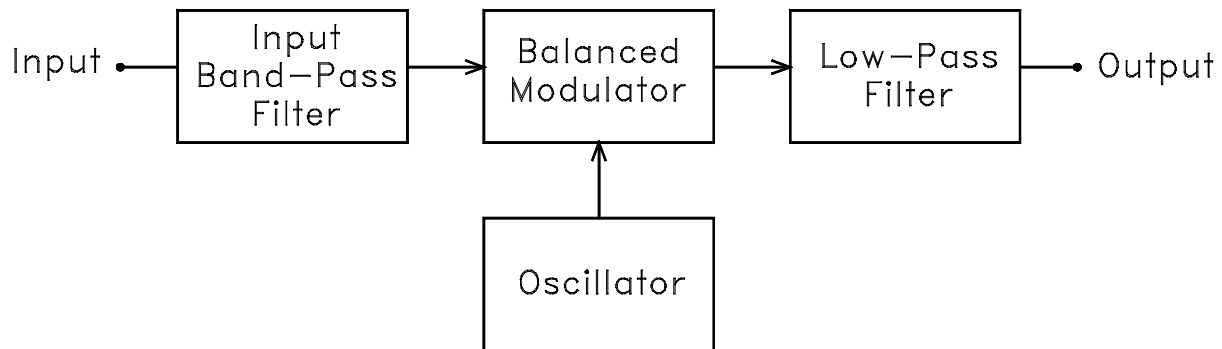

Figure 1: Block diagram of the voice scrambler.

The Balanced Modulator

A balanced modulator is a circuit which multiplies two signals. A four-quadrant multiplier is an example circuit which can be used for this. For this design project, a simpler circuit consisting of a switch hitter with a JFET switch is to be used. An example circuit is shown in Figure 2. The audio input signal is applied to the V_i input. A square-wave is applied to the V_{sq} input. The square wave causes JFET J_1 to alternately switch between a short circuit and an open circuit. When J_1 is an open circuit, the gain is $V_o/V_i = +1$. When J_1 is a short circuit, the gain is $V_o/V_i = -1$. Thus the polarity of the audio signal is reversed

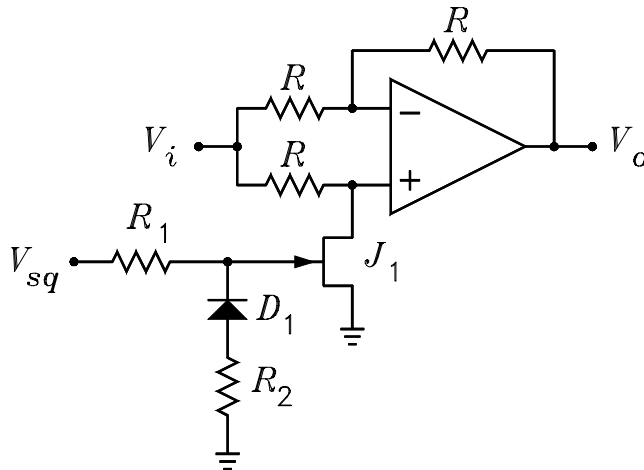

Figure 2: Example balanced modulator circuit.

each time the square wave switches states. This effectively multiplies the audio signal by a square wave.

If the output signal V_o is low pass filtered with a filter having a cutoff frequency less than the frequency of the square wave, it can be shown that V_o is the same as if V_i were multiplied by a sine wave having the same frequency as the square wave. Thus the combination of the square wave multiplier and a low pass filter does the same thing as a four-quadrant multiplier driven by the audio signal and a sine wave oscillator. Resistors R_1 and R_2 and diode D_1 in Figure 2 prevent the gate of J_1 from being overdriven. When V_{sq} is positive, the gate-channel diode is forward biased and R_1 limits the current. When V_{sq} is negative, D_1 is forward biased and voltage division between R_1 and R_2 limit the negative voltage applied to the gate of J_1 to prevent breakdown of the gate-channel diode. The 2N5457 JFET is specified for J_1 . When the square wave goes positive, R_1 should be chosen to limit the gate current to approximately 0.2 mA. When the square wave goes negative, R_2 should be chosen to limit the gate voltage to approximately -5 V. The resistors labeled R in the circuit should be in the range from 10 k Ω to 100 k Ω .

Frequency Considerations

Let the audio input signal be filtered to the band $f_1 < f < f_2$ and let the square wave have the frequency f_0 . When the audio signal is multiplied by the square wave, the frequency components that lie below f_0 are in the band $f_0 - f_2 < f < f_0 - f_1$. The next band of frequencies are in the range $f_0 + f_1 < f < f_0 + f_2$. The output of the scrambler is to be the lower of these two bands. Thus the bandwidth that lies between them is $(f_0 + f_1) - (f_0 - f_1) = 2f_1$. A target value for f_1 is 300 Hz. This gives a bandwidth between the bands of 600 Hz. The low-pass filter at the output must have a very sharp cutoff in order to filter out the upper band with such a small bandwidth between the bands. An elliptic low-pass filter is a good choice for this.

Specifications

- The input band-pass filter is to have the target lower and upper -3 dB cutoff frequencies of 300 Hz and 3000 Hz.

- The square wave oscillator is to have the target frequency of 3300 Hz.
- The output low-pass filter is to have a response that is as flat as possible to 3000 Hz and roll off as fast as possible above that frequency. An odd-order elliptical filter is suggested for this filter. The elliptical filter exhibits nulls in its response. The first null in the elliptical filter should be in the band from 3000 to 3600 Hz.

Schedule

- A preliminary design for each block in the system is due in lab on October 4.
- A preliminary SPICE simulation of at least one block in the system is due in lab on October 11.
- You should complete the project and have it checked off by the lab instructor in lab on October 18.
- The lab report is due in lab on October 25. A SPICE simulation of each block should be included in the report.