

A Low Voltage, Dynamic, Noninverting, Synchronous Buck-Boost Converter for Portable Applications

Biranchinath Sahu, *Student Member, IEEE*, and Gabriel A. Rincón-Mora, *Senior Member, IEEE*

Abstract—With the increasing use of low voltage portable devices and growing requirements of functionalities embedded into such devices, efficient power management techniques are needed for longer battery life. Given the highly variable nature of batteries (e.g., 2.7–4.2 V for Li-ion), systems often require supply voltages to be both higher and lower than the battery voltage (e.g., power amplifier for CDMA applications), while supplying significant current, which is most efficiently generated by a noninverting buck-boost switching converter. In this paper, the design and experimental results of a new dynamic, noninverting, synchronous buck-boost converter for low voltage, portable applications is reported. The converter's output voltage is dynamically adjustable (on-the-fly) from 0.4 to 4.0 V, while capable of supplying a maximum load current of 0.65 A from an input supply of 2.4–3.4 V. The worst-case response time of the converter for a 0.4 to 4 V step change in its output voltage (corresponding to a 0.2 to 2 V step at its reference input) is less than 300 μsec and to a load-current step of 0 to 0.5 A is within 200 μsec , yielding only a transient error of 40 mV in the output voltage. This paper also presents a nonmathematical, intuitive analysis of the time-averaged, small-signal model of a noninverting buck-boost converter.

Index Terms—Dynamic converter, noninverting buck-boost converter, time-averaged modeling.

I. INTRODUCTION

CURRENT trends in consumer electronics demand progressively lower supply voltages due to the unprecedented growth and use of wireless appliances. Portable devices, such as laptop computers and personal communication devices require ultra low-power circuitry to enable longer battery operation. The key to reducing power consumption while maintaining computational throughput and quality of service is to use such systems at the lowest possible supply voltage. The terminal voltage of the battery used in portable applications (e.g., NiMH, NiCd, and Li-ion) varies considerably depending on the state of their charging condition. For example, a single NiMH battery cell is fully charged to 1.8 V but it drops to 0.9 V before fully discharged [1]. Therefore, systems designed for a nominal supply voltage (say, 1.5 V with a single NiMH

battery cell) require a converter capable of both stepping-up and stepping-down the battery voltage.

While both buck (step-down) and boost (step-up) converters are widely used in power management circuits, little attention has been given to integrated buck-boost converters for portable applications. Inverting buck-boost converters and Cuk converters [2] are capable of converting supply voltages to both higher and lower voltages, but the polarity of the output voltage is opposite to the supply voltage. While these converters are suitable to generate the required noninverting buck-boost voltage with the battery terminals interchanged (i.e., positive terminal connected to ground and negative terminal connected to the converter input supply), the same battery cannot be used to supply power for other subsystems in a system-on-chip (SOC) environment, thereby finding limited application. Isolated converter topologies such as Flyback converters [2], [3], are not suitable for low voltage, portable applications because they use a transformer, which increases the board space and overall weight of the devices, not to mention cost and poor efficiency. Alternatively, a boost converter followed by a linear regulator [4] can be used for generating higher and lower voltages from a single supply. However, linear regulators are considerably less efficient and not suitable for applications where load current is high and battery lifetime is critical. Therefore, the only two plausible topologies left for generating a voltage higher and lower than the supply are: (a) noninverting buck-boost converter [2], [5], which is essentially achieved by cascading a buck with a boost converter, and (b) single-ended primary-inductance converter (SEPIC) [2]. The trend in portable applications is to use the topologies that incorporate less number of external components and move closer to cost effective SOC designs. Because SEPIC uses two inductors and two capacitors to transform energy from the battery to the load, the single-inductor, noninverting buck-boost converter, irrespective of its complexity, is clearly the most suitable topology for a portable, cost-effective, low-power environment. The ability to work over a wide range of input voltage to generate both higher and lower voltages while supplying high current makes this topology an attractive choice [6]. While the reported design in [5] is claimed to be the power industry's first buck-boost dc/dc converter [7], its ability to respond to dynamically adaptive reference control signal has not been reported. Furthermore, the minimum output voltage of the converter is 2.5 V, which is not suitable for applications requiring lower supply voltages.

Manuscript received January 27, 2003; revised August 22, 2003. This work was supported by the National Semiconductor Corporation through the Yamacraw Research Initiative at the Georgia Institute of Technology. Recommended by Associate Editor C. A. Canessin.

The authors are with the Analog Integrated Circuits Laboratory, Georgia Tech Analog Consortium, School of Electrical and Computer Engineering, Georgia Institute of Technology, Atlanta, GA 30332 USA (e-mail: bsahu@ece.gatech.edu; rincon-mora@ece.gatech.edu).

Digital Object Identifier 10.1109/TPEL.2003.823196

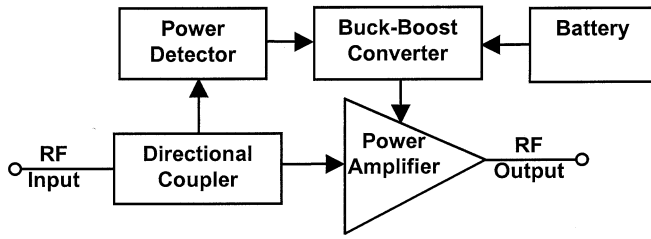

Fig. 1. Block diagram of a linear power amplifier system with dynamic supply.

An application where noninverting buck-boost converters are in high demand is dynamically adaptive supplies for efficient, linear power amplifiers (PAs) in radio frequency (RF) transceivers used for communicating with base stations in portable wireless devices [8]. To prolong battery life, the power efficiency of the PA is improved by dynamically changing the supply voltage and current, on-demand. An efficient linear PA scheme with a dynamic buck-boost converter supply voltage is shown in Fig. 1. The buck-boost converter, depending on a reference control signal adjusts the supply voltage to the PA. To implement closed-loop power control in modern communication systems [9], based on its distance from the base station, the transmitter adjusts the strength of the RF signal at the antenna. Since the gain of the PA is constant for the entire output power range, depending on the input RF power, which is also representative of the power handled by the PA, the reference control signal of the buck-boost converter is generated—a detailed description of this scheme is found in [8]. Since the transmitted power is adjusted in real time, a dynamically adaptive buck-boost converter is required, the design and implementation of which is the subject of this paper. Other applications, such as MPEG-4 codecs [10] and dynamic voltage scaling (DVS) processors [11] require variable supply voltages, depending on the workload, to enable longer battery operation in portable devices.

The paper is organized as follows. The single-inductor, noninverting synchronous buck-boost converter is discussed and its key waveforms are presented in Section II. In Section III, an intuitive, nonmathematical explanation of the time-averaged small-signal model of the power stage of the buck-boost converter is discussed. Analysis for different loading conditions and design considerations, including stability and frequency compensation, of a voltage-mode buck-boost converter are presented. Analytical expressions for critical power loss mechanisms in the converter are highlighted. Section IV describes the details of the hardware design and implementation of the experimental prototype converter. In Section V, results of the prototype converter and discussions are offered. Finally, the paper is concluded in Section VI.

II. BACKGROUND

A noninverting buck-boost converter is essentially a cascade combination of a buck converter followed by a boost converter, where a single inductor-capacitor is used for both [2], [6]. For low voltage implementations, the efficiency of the converter is improved by replacing the rectifier diodes with switches, which results in a synchronous converter

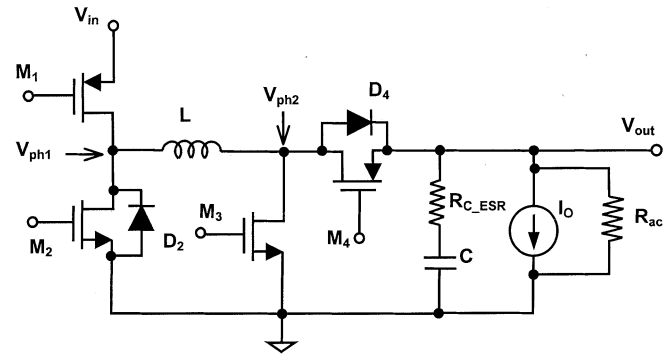

Fig. 2. Noninverting synchronous buck-boost dc-dc converter.

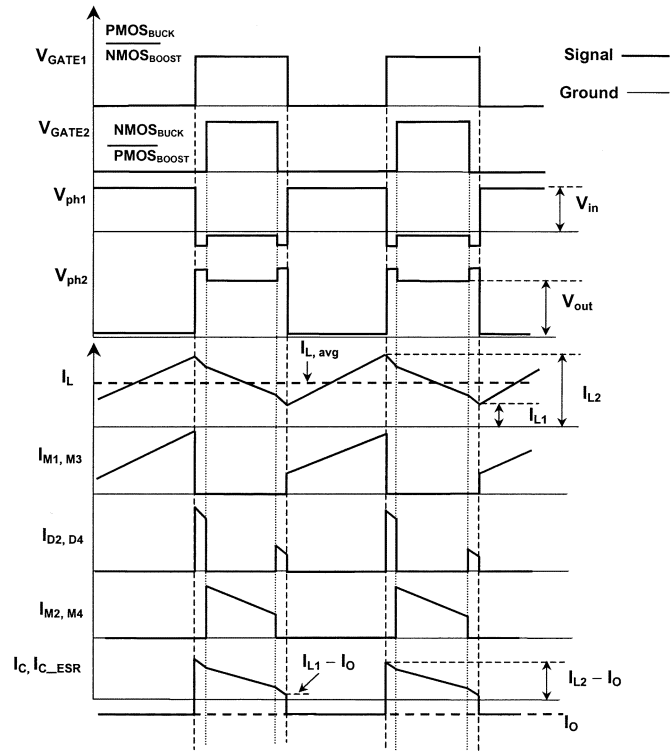

Fig. 3. Important waveforms of the noninverting, synchronous buck-boost dc-dc converter.

topology. The schematic of a synchronous buck-boost converter power stage is shown in Fig. 2. The notations used for the schematic are as follows. V_{in} = Supply voltage, V_{out} = Steady state output voltage, I_O = Output current, L = Inductor value, C = Capacitor value, R_{C_ESR} = Equivalent series resistance (ESR) of the capacitor, and R_{ac} = Resistance of the load during change in output voltage (ac condition). The key voltage and current waveforms of the converter are presented in Fig. 3.

During the T_{ON} period of the cycle, switches M_1 and M_3 are ON and the input voltage is impressed across the inductor. Since the load current is instantaneously provided by the output capacitor during this interval, the capacitor voltage (output voltage) decreases. During the other interval of the switching period (T_{OFF}), switches M_2 and M_4 are turned on and the inductor energy is transferred to the output, providing both the load current and also charging the output capacitor. There is

a time delay (known as *dead-time*) between turning off M_1 , M_3 and turning on M_2 , M_4 to prevent shoot-through current. During this period, the inductor current flows through body diodes D_2 and D_4 , from transistors M_2 and M_4 , respectively. The duty cycle (D) of the converter is given by

$$D = \frac{T_{ON}}{T_{ON} + T_{OFF}} = \frac{T_{ON}}{T} \quad (1)$$

where T is the switching time period of the converter.

Since the node V_{ph1} is connected to V_{in} for DT time over a period of T , the average voltage $V_{ph1,avg} = DV_{in}$. Similarly, the average node voltage of V_{ph2} can be given by $V_{ph2,avg} = D'V_{out}$ ($D' = 1 - D$). Under steady-state operating condition, the inductor can be treated as short, and the average voltage of V_{ph1} and V_{ph2} are equal

$$DV_{in} = D'V_{out} \Rightarrow \frac{V_{out}}{V_{in}} = \frac{D}{1-D}. \quad (2)$$

For the duty cycle of 0.5, the output voltage is equal to the input voltage. When duty cycle is less than 0.5, the output voltage is lower than the input (*buck mode*), and for duty cycle greater than 0.5, the output voltage is higher than the input (*boost mode*).

For low output voltages below the threshold voltage of the PMOS (M_4 in the schematic), the transistor never turns ON, leaving only the diode D_4 as the switch resulting in asynchronous operation of the converter, which is inefficient because of the large voltage drop across the body diode. A transmission gate, which is a parallel combination of a PMOS and a NMOS with complimentary logic inputs to their gates, can be used in place of PMOS boost transistor (M_4) to operate the converter in synchronous mode. For output voltages below the threshold voltage of PMOS, the NMOS acts as switch, and for higher output voltages, NMOS turns-off while PMOS act as a switch. For intermediate output voltages, both PMOS and NMOS of the transmission gate remain ON to share the current during the switching interval in which the inductor is connected to the output.

III. SYSTEM DESIGN CONSIDERATIONS

A. Time-Averaged Small-Signal Model Intuitive Explanation

Feedback control system is employed in dc-dc converters to regulate the output voltage, regardless of the changes in input voltage or loading conditions. To design the feedback control loop of dc-dc switching regulators, an equivalent small-signal model of the power stage is required that is valid for low frequency perturbation of the duty cycle. To model the power stage of converters, techniques such as state-space averaging and circuit averaging [2], [12] have been used extensively. However, the derivation is mathematically complex and difficult to relate to intuitive operation. In this section, a time-averaged model for a synchronous buck-boost converter power stage is explained intuitively with precise one-to-one mapping with the operation of the circuit.

1) *Small Signal Model of the Power Stage With Respect to Change in Duty Cycle (D)*: When the duty cycle changes (e.g., from steady-state value D to $D + d$, where d is the change in the duty cycle), the following changes occur in the circuit, which can be directly associated with the small-signal model [shown in

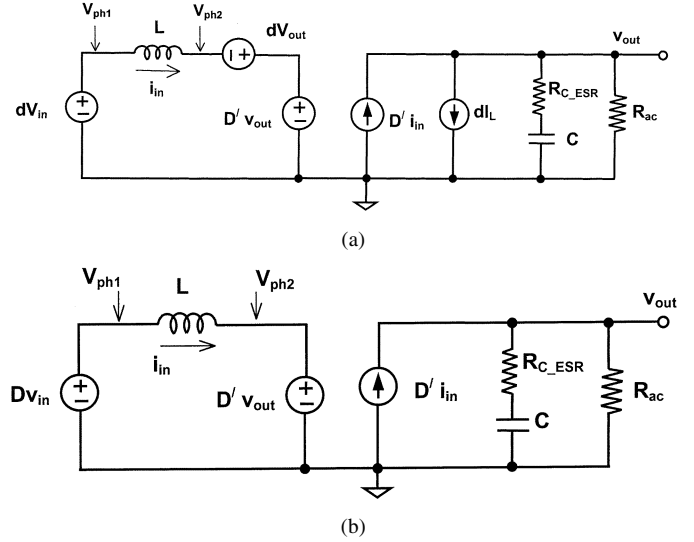

Fig. 4. Time-averaged small-signal model of the buck-boost converter power stage with respect to change in (a) duty cycle and (b) line (input) voltage.

Fig. 4(a)]. Upper-case letters (e.g., V_{out} , V_{in} , D , etc.) are used to represent state-state values and lower-case letters (e.g., v_{out} , v_{in} , d , etc.) are used for small-signal (ac) parameters throughout the text.

Since the node V_{ph1} (DV_{in} in steady-state) is connected to V_{in} for an interval dT more often in the period T , the node voltage increases to $V_{ph1} + dV_{in}$, which is represented by a voltage source dV_{in} in the small signal model [Fig. 4(a)]. Since node V_{ph2} is connected to ground for an interval dT more often in the period T (and to V_{out} dT interval less often), the node voltage decreases to $V_{ph2} - dV_{out}$. This decrease in voltage is represented by a voltage source dV_{out} of opposing polarity. Inductor current I_L flows into the output node d times less than that in the steady state, which is replaced by a current source dI_L flowing out of output node v_{out} . Because of the increase in voltage across the inductor, there is a net increase in inductor current, i_{in1} . Part of this current, $\{(D' - d)i_{in1} \approx D'i_{in1}$, $d \ll D$ is assumed for small-signal conditions} flows into the output node. Therefore, the net current $D'i_{in1} - dI_L$ flowing into the output node increases the output voltage to $V_{out} + v_{out1}$. Due to the increase in output voltage, node voltage V_{ph2} increases by $(D' - d)v_{out1} \approx D'v_{out1}$, which reduces the inductor current from i_{in1} to i_{in} and settles down the output voltage increase to v_{out} . The equivalent circuit model shown in Fig. 4(a) represents these parameters.

The control-to-output transfer function, without considering R_{C_ESR} , is given by

$$\frac{v_{out}}{d} = \frac{V_{out}}{DD'} \left(\frac{1 - \frac{s}{\left(\frac{D'^2 V_{out}}{DLI_O}\right)}}{1 + \frac{s}{\frac{D'^2 R_{ac}}{L}} + \frac{s^2}{\frac{L}{LC}}} \right) \quad (3)$$

which is consistent with the equation for the inverting buck-boost converter [2].

2) *Small-Signal Model of Power Stage With Respect to Change in Line (Input) Voltage*: When the input voltage changes from V_{in} to $V_{in} + v_{in}$, the following changes occur in the power stage (Fig. 2). Node voltage V_{ph1} increases by Dv_{in} and can be represented by a voltage source [Fig. 4(b)].

TABLE I
SMALL-SIGNAL TRANSFER FUNCTION PARAMETERS OF THE NONINVERTING BUCK-BOOST CONVERTER

	Change in duty cycle	Change in line voltage	Units
DC Gain	V_{out} / DD'	D / D'	-
Center frequency	$D' / 2\pi\sqrt{LC}$	$D' / 2\pi\sqrt{LC}$	Hz
Denominator Q	$D'R_{ac} / \sqrt{L/C}$	$D'R_{ac} / \sqrt{L/C}$	-
Right-half plane zero	$D'^2 (V_{out} / I_O) / 2\pi DL$	∞	Hz
Left-half plane zero	$1 / 2\pi R_{C_ESR} C$	$1 / 2\pi R_{C_ESR} C$	Hz

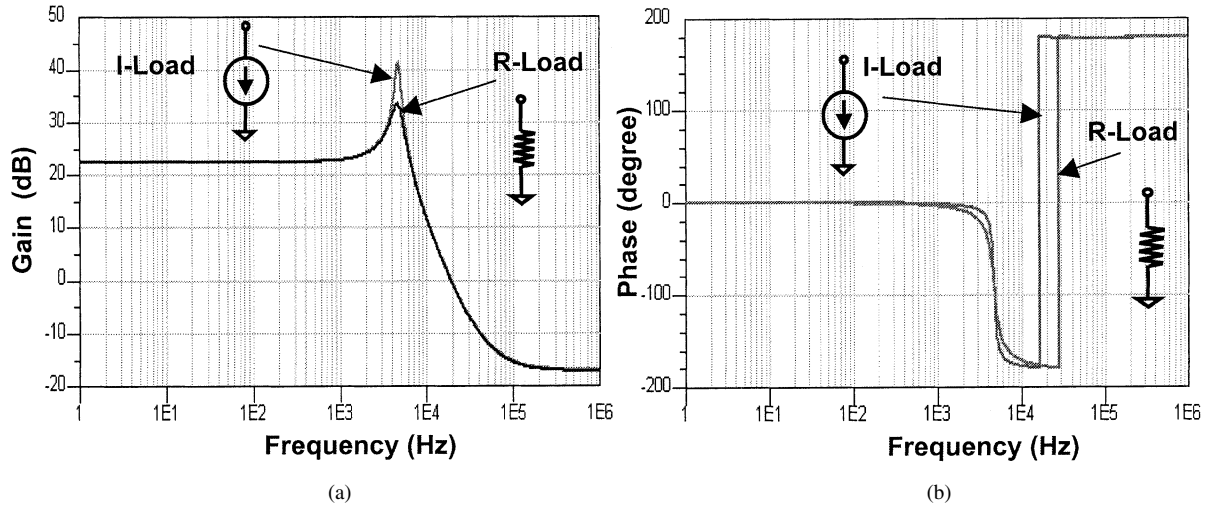

Fig. 5. Frequency response: (a) gain and (b) phase plots of the time-averaged, power stage control-to-output small-signal model for resistive and current sink loads.

Due to the increase in voltage across the inductor, the inductor current increases by i_{in1} , part of which flows into the output node as $D'i_{in1}$, increasing the output voltage by v_{out1} . The increase in output voltage increases the node voltage V_{ph2} by $D'v_{out1}$, which reduces the inductor to i_{in} , and ultimately settles down the output voltage to v_{out} . These parameters are represented in the equivalent circuit model shown in Fig. 4(b).

The line-to-output transfer function, without considering R_{C_ESR} , is given by

$$\frac{V_{out}}{V_{in}} = \frac{D}{D'} \left(\frac{1}{1 + \frac{s}{\frac{D'^2 R_{ac}}{L}} + \frac{s^2}{\frac{D'^2}{LC}}} \right). \quad (4)$$

Equations (3) and (4) are compared with the standard second order transfer function [2], and expression for dc gain, poles and zeros are presented in Table I. Also, the effect of the output capacitor ESR, which introduces a left-half plane (LHP) zero in both the transfer functions is shown.

B. Analysis of the Transfer Functions for Different Loads

The load at the converter output can vary significantly depending on the application. To design the converter's control-loop compensation that is stable across all loading conditions, the transfer functions (derived earlier in Section III-A) are analyzed for the two extremes: a) a pure current source load with high ac output impedance and b) a simple resistive load with relatively low impedance (equal to value of the resistor). For loads with equal current, the ac impedance (R_{ac}) modulates

the quality factor (Q-factor) of the second-order denominator of both the transfer functions [(3) and (4)] between the two extremes identified. The gain and phase plots comparing the control-to-output transfer function frequency response for the two loads are presented in Fig. 5. The parameters used for generating the plots are: $D = 0.75$, $R = 10 \Omega$ (resistive load), $I_O = 0.4 \text{ A}$ (current source load), $L = 2.2 \mu\text{H}$, $C = 47 \mu\text{F}$, $R_{C_ESR} = 70 \text{ m}\Omega$, $R_{ac} = 10 \Omega / 1 \text{ M}\Omega$ (resistive/current source load), and $V_{in} = 3.0 \text{ V}$. For a resistive load, a change in the output voltage directly translates to a change in the load current, thereby absorbing the extra energy during the peak, which is ultimately reflected as degraded Q-factor. For a current-source load, a change in the output voltage does not affect its current (because of its high impedance); consequently Q is higher. The real part of the complex-conjugate poles, the right- and left-half plane (capacitor ESR) zeros remain unchanged under both loading conditions.

C. Control Scheme and Frequency Compensation

While other controlling schemes [13] can be used for closed-loop control, voltage mode was considered for this design because of its simplicity (no inductor current information is required). Voltage-mode control enjoys popularity in the industry for simple, point-of-load dc-dc converter applications [14]. As with the boost converter, the right-half plane (RHP) zero limits the unity-gain frequency (UGF) of the closed-loop performance of the buck-boost converter. Therefore, the RHP zero is designed to reside far beyond the UGF. Considering the expression given

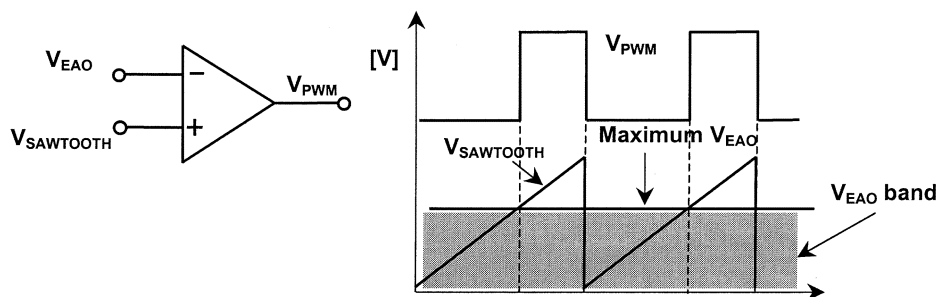

Fig. 6. Illustration of the buck-boost converter duty-cycle limiting.

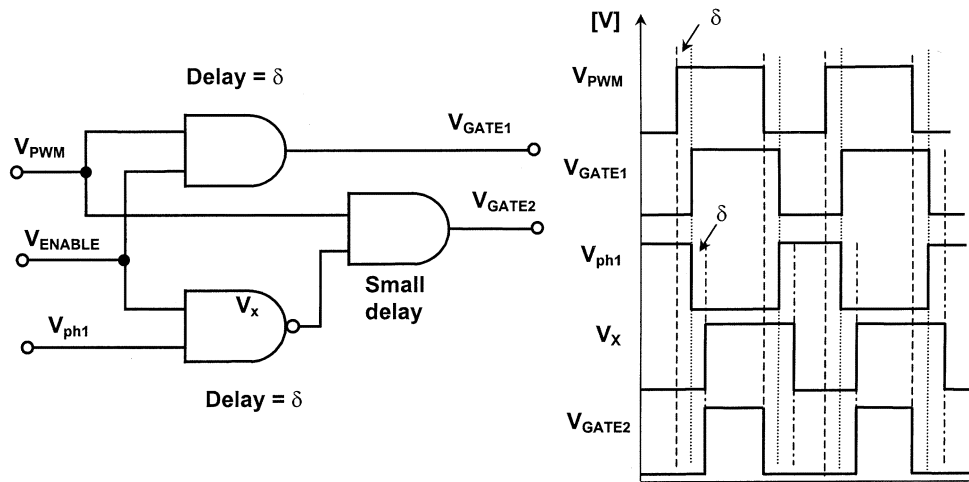

Fig. 7. Fixed dead-time control scheme and relevant waveforms of the buck-boost converter.

in Table I, the RHP zero is at the lowest frequency when the duty cycle is at its peak, which corresponds to the highest output voltage value. For a specified V_{out} , load current I_O , and input voltage V_{in} combination, a smaller inductor pushes out the RHP zero, which results in higher peak-current rating requirements for the switching devices and induces more RMS power losses in the current-flowing path.

Therefore, the compensation design depends on the location of the left-half plane (LHP) zero arising as result of the ESR of the output capacitor. Feedback-loop compensation design for the two cases: a) when the ESR zero is located within the desired UGF and b) when the ESR zero is far from the desired UGF have been explained in [3], [15]. Since the location of the transfer function poles and zeros vary with the duty cycle, the converter is compensated for the lowest frequency poles and zeros, which occurs when the duty cycle is at its peak.

D. Duty-Cycle Limiting

During start-up and transient (load and control voltage) events, the duty cycle changes between extremes. For example, during start-up, the reference voltage can be higher than the feedback voltage, especially if considering an independent, dynamic voltage reference. Consequently, the error amplifier's output goes to the positive rail, in other words, equal to or greater than the peak sawtooth voltage, which results in the PWM comparator's output reaching the negative rail throughout the entire switching period. The transistors M_1

and M_3 (Fig. 2) are therefore turned on, impressing the input voltage upon the inductor. The inductor current never flows into the output during this interval; therefore, the output voltage remains unchanged. However, the inductor current continues to increase until the resistance of the path limits it, but such a high current can damage the inductor and power switches, even before reaching the limit. This phenomenon is avoided by choosing the positive rail supply voltage of the error amplifier to be less than the peak value of the sawtooth waveform, as shown in Fig. 6, thereby limiting the duty cycle to less than unity.

E. Dead-Time Control

Dead-time control in synchronous converters is required to prevent "shoot-through current" which is an unnecessary power loss resulting when the rectifier and pass transistors are both conducting current simultaneously. A simple fixed-delay dead-time control scheme is adopted for the discrete prototype presented in this paper. The schematic of the control scheme and the relevant waveforms are shown in Fig. 7. The delay time of the logic gates 1 and 2, δ , is assumed to be much larger than signal delay in the power transistors and in gate 3. In the prototype implementation, RC circuits are used in conjunction with logic gates 1 and 2 to realize these delays. Advanced schemes (e.g., adaptive and predictive dead-time controls [16]) may be implemented to reduce body-diode conduction, gate-drive and switching losses in the converter.

TABLE II
SUMMARY OF POWER LOSSES IN THE BUCK-BOOST CONVERTER

Mechanism	Expression
CONDUCTION LOSSES	
Buck-PMOS and Boost NMOS	$DI_{L,rms}^2 (R_{DS_PMOS} + R_{DS_NMOS})$
Buck-NMOS and Boost PMOS	$(1-D-(2t_{dead}/T_s))I_{L,rms}^2 (R_{DS_NMOS} + R_{DS_PMOS})$
Body diodes	$(2t_{dead}/T_s)I_{L,rms} V_{DIODE}$
Inductor resistive loss	$I_{L,rms}^2 R_{L_ESR}$
Capacitor ESR loss	$(DI_{OUT}^2 + (1-D)(\Delta I_L^2/12))R_{C_ESR}$
SWITCHING LOSSES and CORE LOSSES	
V-I overlap for V_{ph1}	$I_L V_{IN} t_X f_s$
V-I overlap for V_{ph2}	$I_L V_{OUT} t_Y f_s$
NMOS gate-drive losses	$2C_{ISS,NMOS} V_{GATE}^2 f_s$
PMOS gate-drive losses	$C_{ISS,PMOS} (V_{IN}^2 + V_{OUT}^2) f_s$
Core loss	$k I_{L,peak}^2 f_s$

F. Power Loss Analysis

Theoretical estimation of power losses in the converter is required to determine the efficiency limit and improve its efficiency further using power saving techniques. Mathematical expressions for power loss mechanisms in switching converters are found in [2], [3], [17]. The power loss equations for a buck-converter given in [18] are extended for the buck-boost converter, and are summarized in Table II. Various notations used in the table are as follows. $I_L/I_{L,rms}/\Delta I_L$ = Average/RMS/peak-to-peak inductor current, t_{dead} = Dead time, R_{DS} = Transistor ON resistance, V_{DIODE} = Body-diode voltage drop, R_{L_ESR} = Inductor, I_{OUT} = Output current, $f_s = 1/T_s$ = Switching frequency, C_{ISS} = Input capacitance of the switching transistor, t_X/t_Y = Voltage and current overlap time during switching on and off at V_{ph1}/V_{ph2} node, V_{GATE} = NMOS gate-drive voltage, k = Core loss factor of the inductor.

IV. HARDWARE DESIGN AND IMPLEMENTATION

To realize a dynamic, noninverting, buck-boost converter for the efficient linear power amplifier (PA) system (Fig. 1), the output voltage is chosen to vary from 0.4–4.0 V, and input voltage of 2.4–3.2 V is selected to illustrate converter's ability to regulate under varying input supply. A switching frequency of 500 kHz is chosen for smaller inductor and capacitor and sufficient open-loop bandwidth (20 kHz, in this case) to meet the transient requirements of the PA application. Details of the converter specifications are presented in Table III.

A. Power Stage Design

1) *Selection of Inductor:* The maximum value of duty cycle (D_{max}) is calculated to be 0.62, using the expression

$$D = \frac{V_{out} + 2V_{SW}}{V_{in} + V_{out} - 2V_{SW}} \quad (5)$$

where the voltage drops across the switches (V_{SW}) is assumed to be 0.1 V, output voltage V_{out} is substituted with its maximum

TABLE III
PROTOTYPE BUCK-BOOST CONVERTER SPECIFICATIONS

Parameter	Value
Input voltage	2.5 - 3.2 V
Output voltage	0.4 - 4.0 V
Load current	0.05 - 0.8 A
Ripple voltage	≤ 100 mV
Load resistance	5 - 7 Ohms
Switching frequency	500 kHz

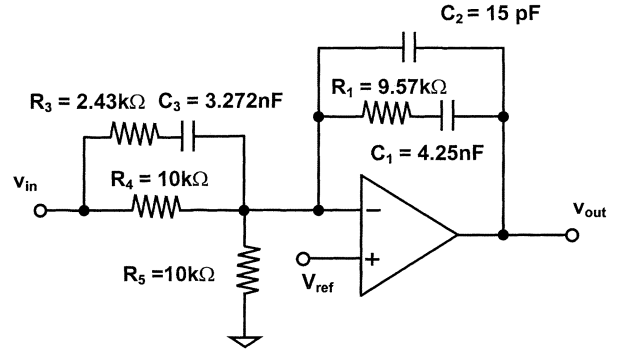

Fig. 8. Type-III network (2-zeros and 3-poles) designed for compensating the buck-boost converter.

value 4.0 V, and input voltage V_{in} of 3.0 V. The maximum average inductor current is given as: $I_{L(avg),max} = I_{O,max}/1 - D_{max} = 2.1$ A. Assuming peak-to-peak inductor ripple current to be 1.47 A $\{\Delta I_L = 0.7I_{L(avg)}\}$, the peak current is calculated to be 2.84 A $\{I_{L(peak)} = I_{L(avg)} + \Delta I_L/2\}$. Consequently, the maximum RMS inductor current is 2.14 A $\{I_{L(rms),max} = \sqrt{I_L^2 + \Delta I_L^2/12}\}$, and the value of the inductor is calculated to be 2.36 μ H using

$$L = \frac{(V_{in} - 2V_{SW})D_{max}}{f_s \Delta I_L} \quad (6)$$

For the prototype, an inductor of 2.2 μ H with dc current rating 3.5 A and ripple current rating of 2 A was selected.

2) *Selection of the Output and Input Capacitors:* Since there is no inductive element between the output diode (switch) and the capacitor, large instantaneous values of currents flowing in and out of the output capacitor generates an output ripple voltage which is dependent on its ESR and equivalent series inductance (ESL), which is a parasitic element in series with the capacitor. Assuming the capacitor has a very small ESL, the output ripple voltage (ΔV_O) is given by

$$\Delta V_O = \Delta V_{O,CAP} + \Delta V_{O,ESR} = \frac{I_O D}{f_s C_O} + I_{peak} R_{C_ESR} \quad (7)$$

where $\Delta V_{O,CAP}$ and $\Delta V_{O,ESR}$ are ripple voltages due to the capacitor and its ESR, respectively. For a maximum output ripple voltage of 100 mV, assuming the maximum capacitive ripple voltage is 25 mV and its ESR ripple voltage is 75 mV, the capacitor value is found to be 39.6 μ F with an expected ESR of 27 m Ω . However, because of cost and availability considerations, a tantalum capacitor of 47 μ F with an ESR of 70 m Ω and a voltage rating of 6.3 V was chosen for the prototype design. Consequently, the expected maximum output peak-to-peak ripple is 220 mV for an ideal converter (i.e., 100%

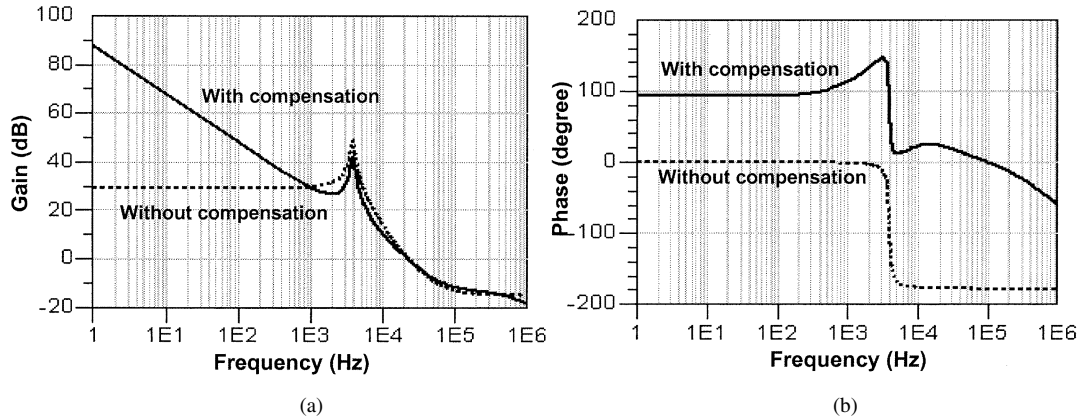

Fig. 9. Frequency response: (a) gain and (b) phase plots of the open-loop control-to-output transfer function of the buck-boost converter with and without error amplifier compensation.

efficient). However, due to the power losses in the converter a higher value of inductor current can be expected, which results in a higher peak-to-peak current flowing out of the output capacitor ESR yielding a higher output ripple.

Similar to the output, the instantaneous value of current coming in and out of the battery is very high in buck-boost converter. To limit the ripple in the line voltage within 100 mV, an input capacitor of 100 μ F (ESR of 70 m Ω) and output voltage rating of 6.3 V is therefore chosen.

3) *Power Transistor Selection*: The peak current rating of the power transistors is equal to the peak inductor current (3.0 A, in this case). The maximum average current flowing through the power switches is the higher of currents $(1 - D_{\min})I_{L,avg}$ and $D_{\max}I_{L,avg}$. Fairchild Semiconductor's NDS9933A dual-PMOS and NDS9958 dual-NMOS transistors are chosen for the prototype.

B. Compensation Design

The converter is designed to be stable for a maximum duty cycle of 0.75 and to achieve a closed-loop, unity-gain frequency (UGF) of 20 kHz. The LC-double poles, capacitor-ESR zero, and RHP zero are calculated (using expressions in Table I) to be 3.912 kHz, 48.37 kHz, and 30.143 kHz, respectively. The dc gain of the power stage and PWM modulator are 26.58 dB and -12.04 dB (corresponding to a peak saw tooth voltage of 4 V), which results in a total open-loop dc gain of 14.54 dB.

A Type-III compensation scheme [4], [15] is chosen, along with the component values shown in Fig. 8. Resistors R_4 and R_5 set the dc filter gain

$$\frac{V_{out}}{V_{ref}} = 1 + \frac{R_4}{R_5}. \quad (8)$$

Two zeros [from R_1C_1 , and the other from $(R_4 + R_3)C_3$] are added at the same frequency as the LC double pole to compensate for the gain and sharp phase change. Assuming C_1 is much larger than C_2 , capacitor C_1 is selected to ensure the open-loop gain of the system (modulator, LC filter, and error amplifier) is 0 dB at the UGF. The values of R_3 and C_3 are chosen to place a pole at the desired UGF, 20 kHz. Capacitor C_2 sets the dominant pole and ensures 20 dB/dec roll-off (detailed expressions can be found in [15]). The gain and phase of the control-to-output

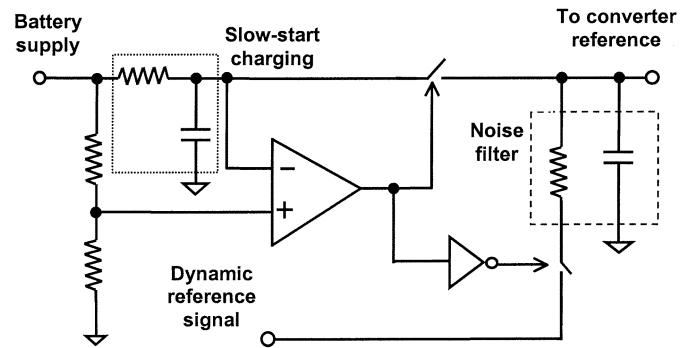

Fig. 10. Slow start and dynamic control reference bypass circuit.

open-loop transfer function with and without compensation are shown in simulation results presented in Fig. 9.

C. Slow-Start and Dynamic Reference Control Signal Bypass Circuit

To reduce initial transients, and prevent catastrophic failures, a start-up circuit was incorporated into the design of the prototype converter (shown in Fig. 10). When the supply is turned on, the comparator output is high and the slowly charging capacitor output voltage is used as a reference voltage for the converter. After the converter reaches a predetermined threshold, the comparator output goes low and the dynamic control signal enables the reference signal to control the dc-dc converter.

V. EXPERIMENTAL RESULTS AND DISCUSSIONS

The node voltage V_{ph1} , output ripple voltage and inductor current waveforms shown in Fig. 11(a) illustrate the functionality of the converter. Gate-drive signals for the PMOS and NMOS of the buck stage and the inductor current waveform shown in Fig. 11(b) verify the functionality of the dead-time control scheme.

Fig. 12(a) and (b) illustrate the variation of percentage error in the output voltage (maximum of 2.8% at 0.4 V with a current source load of 0.4 A) and peak-to-peak ripple (maximum of 275 mV for a load current of 0.65 A) with the output voltage, respectively. The error in the output voltage is attributed to the finite loop gain of the control loop, the parasitic resistance in

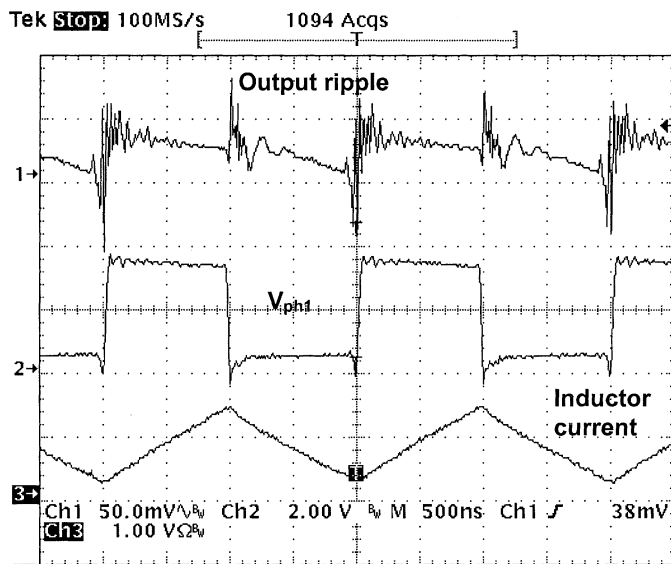

(a)

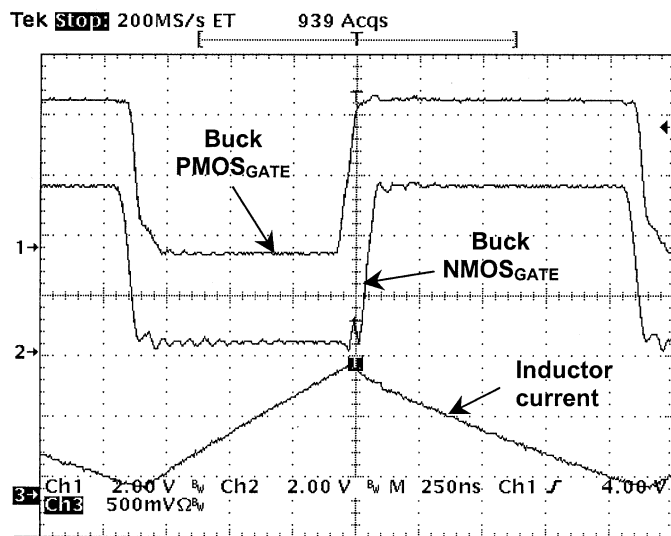

(b)

Fig. 11. Experimental buck-boost converter: (a) output ripple, node voltage V_{ph1} , and inductor current waveforms and (b) gate-drive signals.

the switching-current-flowing path and the offset voltage of the error amplifier. The absolute value of error voltage (which is the product of current and parasitic resistance) is the same for equal load currents—the percentage error decreases with higher output voltage. The ripple in the output is as a result of peak-to-peak ripple current flowing through the ESR and ESL of the output capacitor. For constant load currents, although the average inductor current is constant, ripple inductor current increases for higher output voltages (larger duty cycles). For resistive loads, with higher output voltages the load current increases, leading to higher peak-to-peak ripple currents and consequently higher ripple voltage. Although, the maximum peak-to-peak ripple voltage was estimated for a maximum load current of 0.8 A, due to the power losses in the converter ripple measurement was possible up to 0.65 A for which the theoretically estimated ripple is 188 mV. The error between estimated ripple (188 mV) and measured ripple (275 mV) can

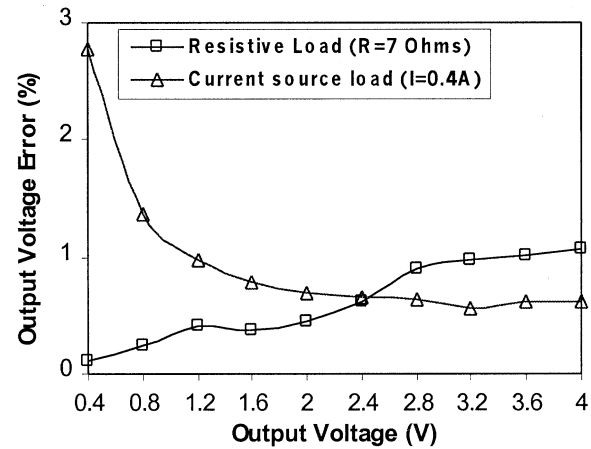

(a)

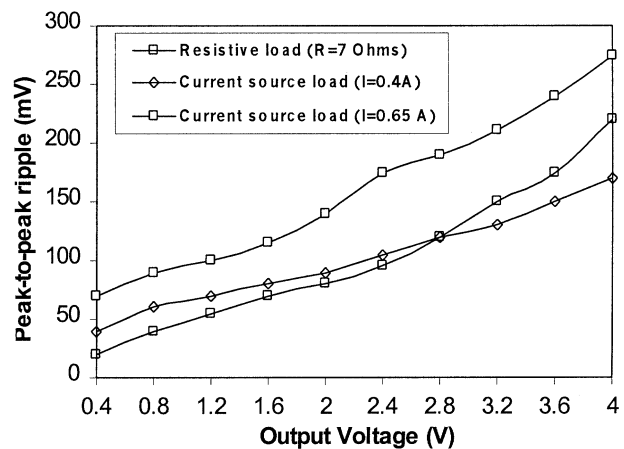

(b)

Fig. 12. (a) Percentage output voltage error and (b) variation of the output ripple voltage of the prototype buck-boost converter.

be attributed to several factors: a) difference between actual current and estimated current flowing through the capacitor ESR because of the power losses in the converter, b) measurement uncertainty because of the capacitor and instrument ESL generated spikes, and c) deviation of actual ESR value of the capacitor from the data sheet specifications.

Efficiency curves of the converter at various load currents and different output voltages are presented in Fig. 13(a) showing higher efficiency at higher load current and output voltage. The efficiency is not very high because the discrete switches used in the prototype are not customized for low voltage applications—they have a much higher ON resistance due to their reduced gate drive. For the same output power with higher current and lower voltage, conduction loss is more than with lower current and higher voltage, resulting in a degraded efficiency. Like other switching converters, the switching loss is dominant at light loading conditions. Theoretical estimation of the converter efficiency for an output voltage of 3.6 V exhibits a reasonable match with the experimental results, as shown in Fig. 13(b).

The line (LNR) and load (LDR) regulation of the converter is limited to 0.3% and -1% , respectively. Fig. 14(a) shows the change in output voltage with a step change in the reference control signal. The converter takes approximately 300 μsec to reach

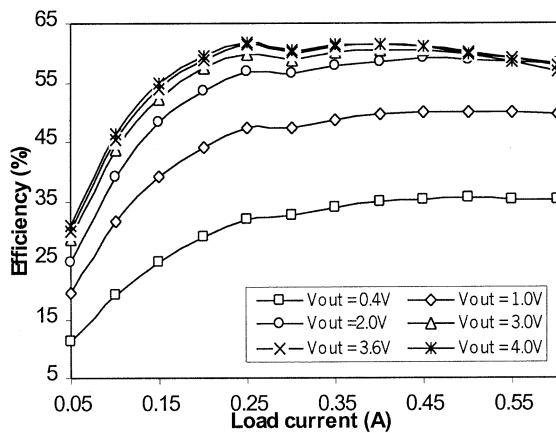

(a)

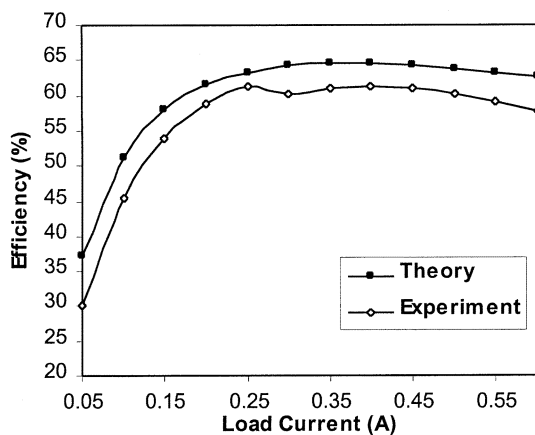

(b)

Fig. 13. (a) Efficiency of the prototype converter under various load currents and at different output voltages and (b) comparison of theoretical and experimental efficiency profiles of the buck-boost converter for an output voltage of 3.6 V.

TABLE IV

EXPERIMENTAL RESULTS OF THE PROTOTYPE BUCK-BOOST CONVERTER

Specifications	Target	Experimental
Input voltage	2.5-3.2 V	2.4-3.4 V
Output voltage	0.4-4.0 V	0.4-4.0 V
Output voltage accuracy	-	0.5-3 %
Peak-to-peak ripple	≤ 100 mV	≤ 275 mV
Line regulation (Range: 2.4-3.4 V)	-	≤ 0.3 %
Load regulation (Range: 0.05-0.6 A)	-	≤ -1.0 %
Efficiency	-	10-62 %
Worst case response to reference signal	≤ 300 μ sec	300 μ sec
Response to load step change	≤ 300 μ sec	200 μ sec

4 V, from its initial condition of 0 V. Fig. 14(b) shows the transient response of the output voltage with a step change in load current of 0.5 A, which exhibits having transient and steady-state error of 40 and 50 mV, respectively, and a response time of 200 μ s. Experimental results of the converter are compared with the targeted values in Table IV, which shows that the converter meets the desired specifications except output ripple voltage, because of the higher value of output capacitor ESR used in the prototype than that is expected from theoretical considerations.

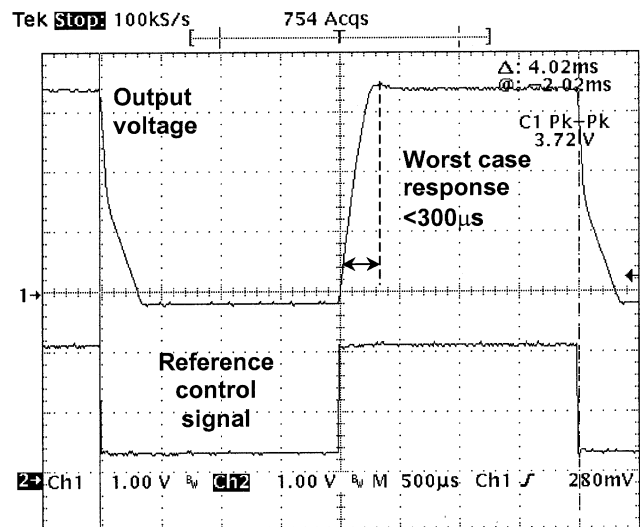

(a)

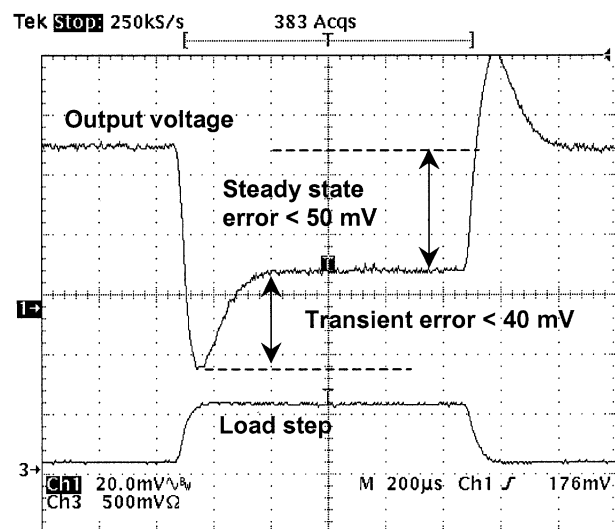

(b)

Fig. 14. Converter response to: (a) worst-case step change in control reference signal and (b) step change in load current.

VI. CONCLUSION

The design and experimental results of a dynamic, noninverting, synchronous, buck-boost converter with wide input supply and output voltage range is presented in this paper. The converter output voltage is dynamically adjustable (on the fly) from 0.4 to 4.0 V, while supplying a load current up to 0.65 A from an input supply of 2.4-3.4 V. The worst-case response times of the converter for a 0.4 to 4 V step and a load-current step of 0 to 0.5 A are less than 300 and 200 μ s, respectively, yielding only an output transient error voltage of 40 mV. The maximum measured output voltage error and peak-to-peak ripple are 2.8% and 275 mV, respectively. The measured ripple is higher than the desired ripple because of the output capacitor used in the prototype has a higher ESR than the expected value. Although the prototype was not optimized for efficiency, its efficiency can be improved by using power transistors with lower ON-resistance values.

An intuitive derivation of the time-averaged model of the power stage of the converter is also discussed, which reveals the characteristics of the system under extreme, worst-case loading conditions from pure current source to a pure resistive load. A pure current source load (infinite output impedance) shows a higher Q at the resonant LC poles frequency. Overall, with the increasing use of battery-operated portable devices, to run the systems at their peak performance levels (even when the battery is close to fully discharged), noninverting buck-boost converters play a pivotal role in the next generation power management circuits, especially as it pertains to SOC implementations.

REFERENCES

- [1] C. Simpson. (2003) Characteristics of Rechargeable Batteries. National.com. [Online]. Available: <http://www.national.com/appinfo/power/files/fv.pdf>.
- [2] R. W. Erickson, *Fundamentals of Power Electronics*, 1st ed. New York: Chapman and Hall, 1997.
- [3] A. Pressman, *Switching Power Supply Design*, 2nd ed. New York: McGraw-Hill, 1998.
- [4] (2003) Maxim Semiconductors' Application Note. [Online] http://www.maxim-ic.com/appnotes.cfm/appnote_number/312
- [5] "Design Applications Notes," Tech. Rep., Linear Technology, Oct. 2001.
- [6] R. Lenk, *Practical Design of Power Supplies*. New York: McGraw-Hill, 1998.
- [7] LTC3440: The power industries first buck-boost dc/dc converter. Tech. Rep., Linear Technology. [Online]. Available: <http://www.soanar.com.au/newsandinfo.cfm?newsid=232&archive=1>
- [8] B. Sahu and G. A. Rincón-Mora, "A high-efficiency, linear RF power amplifier with a power-tracking, dynamically adaptive buck-boost supply," *IEEE Trans. Microwave Theory Tech.*, to be published.
- [9] S. C. Yang, *CDMA RF Systems Engineering*. Norwood, MA: Artech House, 1999.
- [10] F. Ichiba, K. Suzuki, S. Mita, T. Kuroda, and T. Furuyama, "Variable supply-voltage scheme with 95% efficiency DC-DC converter for MPEG-4 codec," in *Proc. Int. Symp. Low Power Electron.*, 1999, pp. 54–59.
- [11] A. Sinha and A. Chandrakasan, "Dynamic power management in wireless sensor networks," *IEEE Design Test Comput.*, vol. 18, pp. 62–74, Mar./Apr. 2001.
- [12] Y. Lee, *Computer-Aided Analysis and Design of Switch-Mode Power Supplies*. New York: Marcel-Dekker, Inc., 1993.
- [13] G. A. Rincón-Mora, "Self-oscillating hysteretic V-mode DC-DC controllers: from the ground up," in *Proc. IEEE Power Electron. Spec. Conf. (PESC) Tutorial*, 2001.
- [14] B. Shaffer, "Internal compensation—Boon or Bane," in *Proc. Power Supply Design Sem. (SEM 1300)*, 2000.
- [15] Texas Instruments, "Designing With the TL5001 PWM Controller," Applicat. Rep. SLVA034A, Texas Instruments, 1995.
- [16] B. Lynch and K. Hesse, "Under the hood of low-voltage dc/dc converters," in *Proc. Power Supply Design Seminar (SEM 1500)*, 2002.
- [17] L. Balogh, "Design and application guide for high speed MOSFET gate drive circuits," in *Proc. Power Supply Design Seminar (SEM 1400)*, 2001.
- [18] G. A. Rincón-Mora, "Integrated dc–dc converters: a topological journey," in *Proc. Midwest Symp. Circuits Syst (MWCAS'02) Tutorial*, 2002.



Biranchinath Sahu (S'01) was born in Nodhana, Orissa, India. He received the B.E. degree (with highest honors) from the University College of Engineering, Burla, India, in 1997 and the M.Tech. degree from the Indian Institute of Technology, Kanpur, India, in 1999, both in electrical engineering, and is currently pursuing the Ph.D. degree in the School of Electrical and Computer Engineering, Georgia Institute of Technology, Atlanta.

His research interests are in the area of mixed-signal circuits and system design, more specifically, integrated power management, and design of energy-efficient, linear RF power amplifiers for battery-powered, portable applications. During Summer 2001, he was an Intern at Analog Devices, Inc., Wilmington, MA, working on the design and simulation of delta-sigma converters for GSM wireless applications. He was a full-time member of the Microelectronics Group, Lucent Technologies, Inc. (now Agere Systems, Inc.), India, in 2000, where he had worked on the development of reduced-order modeling and simulation tools for high-speed interconnects and RF circuits.



Gabriel A. Rincón-Mora (S'91–M'97–SM'01) was born in Caracas, Venezuela. He received the B.S.E.E. degree (with high honors) from Florida International University, Miami, in 1992 and the M.S.E.E. and Ph.D. degrees in electrical engineering from the Georgia Institute of Technology (Georgia Tech), Atlanta, in 1994 and 1996, respectively.

In 1994, he started working with Texas Instruments as a Design Engineer, eventually becoming a Senior IC Designer, Design Team Leader, and Member of Group Technical Staff. In 1999, he was appointed Adjunct Professor for the School of Electrical and Computer Engineering, Georgia Tech. He is presently a full-time member of the faculty at Georgia Tech and the Director of the Georgia Tech Analog Consortium. His research is on analog and mixed-signal integrated circuit design and, more specifically, on low voltage, low power consumption, low/high output power, high efficiency, system-on-chip solutions for power management and other analog system applications, in portable battery-powered and nonportable electronic equipment. His work has focused on the research, design, and development of device physics, circuits, and systems, in different flavors of Bipolar, CMOS, and BiCMOS process technologies. He has numerous patents as well as publications in the field. He also teaches short courses, seminar, and tutorial on the subject of integrated power management. He authored *Voltage References: From Diodes to Precision High-Order Bandgap Circuits* (New York: Wiley, 2001).

Dr. Rincón-Mora received the "National Hispanic in Technology Award" from the Society of Professional Hispanic Engineers, was inducted into the "Council of Outstanding Young Engineering Alumni" by Georgia Tech, received the "Charles E. Perry Visionary Award" from Florida International University, received a "Commendation Certificate" from the Lieutenant Governor of California, and is listed in Marquis' *Who's Who in America*. He is a member of Tau Beta Pi, Eta Kappa Nu, Phi Kappa Phi, and the Society of Hispanic Professional Engineers.