



US007339416B2

(12) **United States Patent**
Rincon-Mora et al.

(10) **Patent No.:** **US 7,339,416 B2**
(45) **Date of Patent:** **Mar. 4, 2008**

(54) **VOLTAGE REGULATOR WITH LOW DROPOUT VOLTAGE**

(75) Inventors: **Gabriel Alfonso Rincon-Mora**, Atlanta, GA (US); **Matthias Arnold**, Moosburg (DE)

(73) Assignee: **Texas Instruments Incorporated**, Dallas, TX (US)

(*) Notice: Subject to any disclaimer, the term of this patent is extended or adjusted under 35 U.S.C. 154(b) by 0 days.

(21) Appl. No.: **11/464,587**

(22) Filed: **Aug. 15, 2006**

(65) **Prior Publication Data**

US 2007/0152742 A1 Jul. 5, 2007

(30) **Foreign Application Priority Data**

Aug. 18, 2005 (DE) 10 2005 039 114

(51) **Int. Cl.**

G05F 1/10 (2006.01)

(52) **U.S. Cl.** **327/538; 327/541; 327/543**

(58) **Field of Classification Search** **327/538, 327/540, 541, 543, 544, 427, 434; 323/265, 323/268, 277, 280**

See application file for complete search history.

(56) **References Cited**

U.S. PATENT DOCUMENTS

6,046,577 A * 4/2000 Rincon-Mora et al. 323/282
6,373,233 B2 * 4/2002 Bakker et al. 323/282

(Continued)

FOREIGN PATENT DOCUMENTS

EP 1280032 1/2003

(Continued)

Primary Examiner—N. Drew Richards

Assistant Examiner—Hai L. Nguyen

(74) *Attorney, Agent, or Firm*—William B Kempler; W. James Brady, III; Frederick J. Telecky, Jr.

(57) **ABSTRACT**

A low dropout voltage regulator (100; 300) comprises a supply input terminal (102; 302) for connecting a supply voltage (V_{DD}) and an output terminal (104; 304) for providing a regulated output voltage (V_o), a reference voltage source (130; 330); and an output voltage monitor (120; 320). An error amplifier (132; 332) has an output (138; 338) supplying an error signal (V_{err}) in response to deviations of the regulated output voltage (V_{out}) from a desired target output voltage value (V_o) at the output terminal (104; 304). A power output FET (110; 310), has a drain-source channel connected between the supply input terminal (102; 302) and the output terminal (104; 304) of the voltage regulator, and a gate terminal (116; 316). The gate terminal of the power output FET (110; 310) is controlled by the error amplifier (132; 332) via a driver FET (140; 340) in such a way that any deviations of the regulated output voltage (V_{out}) from a desired target output voltage value (V_o) are minimized. The regulator further comprises a bypass FET (150; 350) of an n-conductivity type, which has a source terminal (154; 354) connected to the gate terminal (142; 342) of the driver FET (140; 340), a drain terminal (156; 356) connected to the source terminal (112; 312) of the driver FET (140; 340), and a gate (152; 352) connected to a bias voltage source (158; 358). The bias voltage is determined such that the bypass FET (150; 350) begins conducting when the source voltage of the driver FET (140; 340) cannot be further reduced by application of the error signal (V_{err}) to its gate towards the drain potential, due to the inherent gate-source voltage drop (V_{gs}) of the driver FET (140; 340).

4 Claims, 4 Drawing Sheets

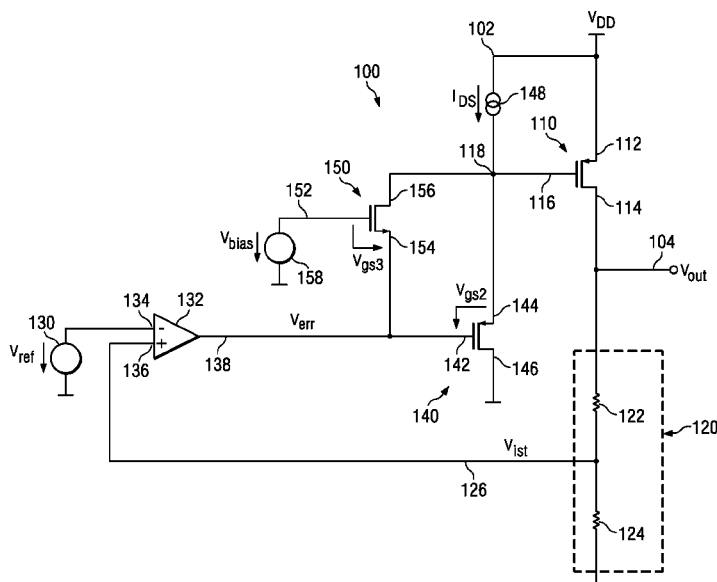

US 7,339,416 B2

Page 2

U.S. PATENT DOCUMENTS

6,414,537 B1 * 7/2002 Smith 327/540
6,465,994 B1 * 10/2002 Xi 323/274
6,501,305 B2 * 12/2002 Rincon-Mora et al. 327/108
6,518,737 B1 * 2/2003 Stanescu et al. 323/280
6,541,946 B1 * 4/2003 Chen et al. 323/280
6,573,694 B2 * 6/2003 Pulkin et al. 323/273
6,703,815 B2 * 3/2004 Biagi 323/280

6,847,260 B2 * 1/2005 Gupta et al. 330/257
2003/0184268 A1 10/2003 Perez et al.
2004/0164789 A1 8/2004 Leung et al.

FOREIGN PATENT DOCUMENTS

EP 1336912 8/2003

* cited by examiner

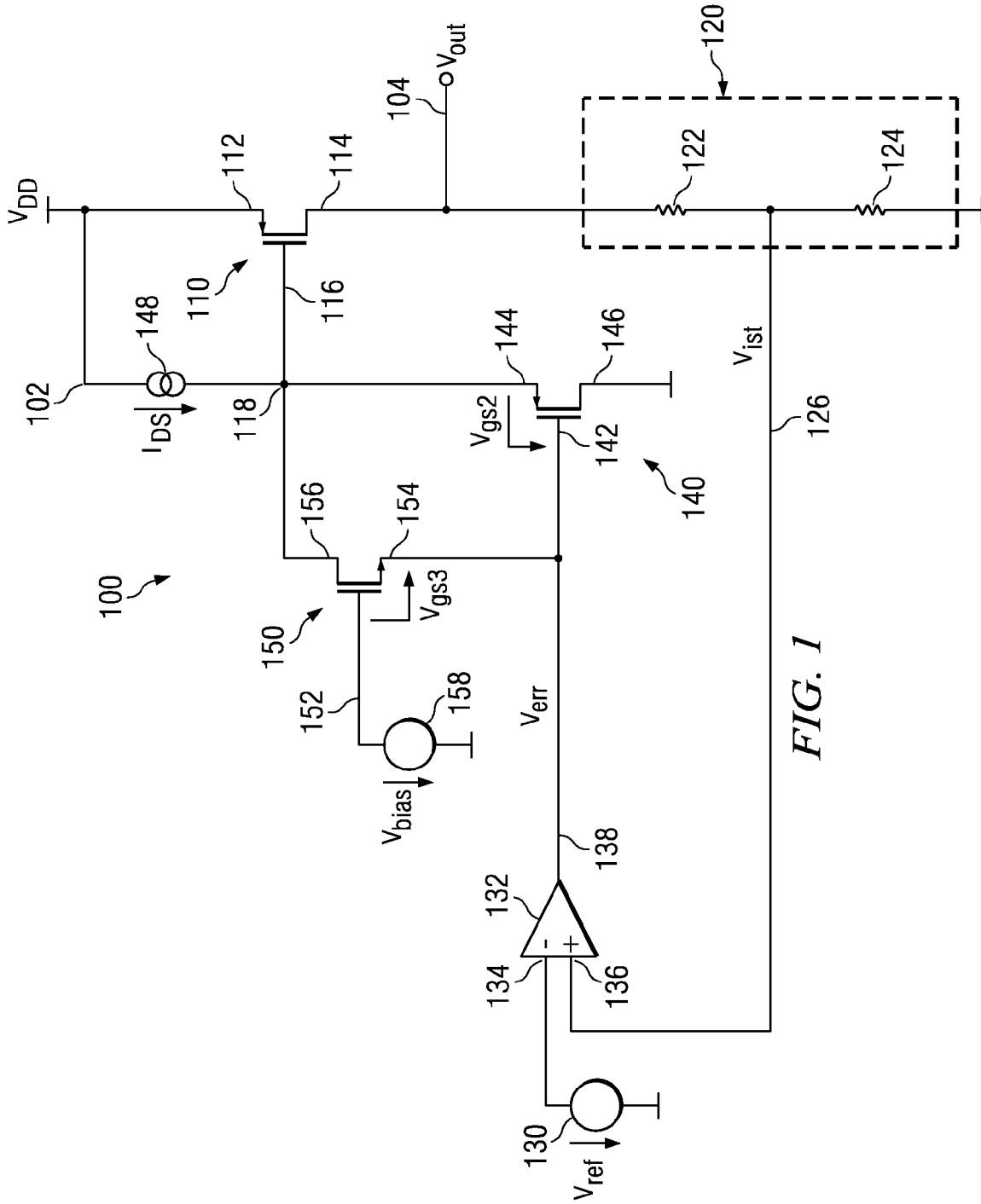

FIG. 1

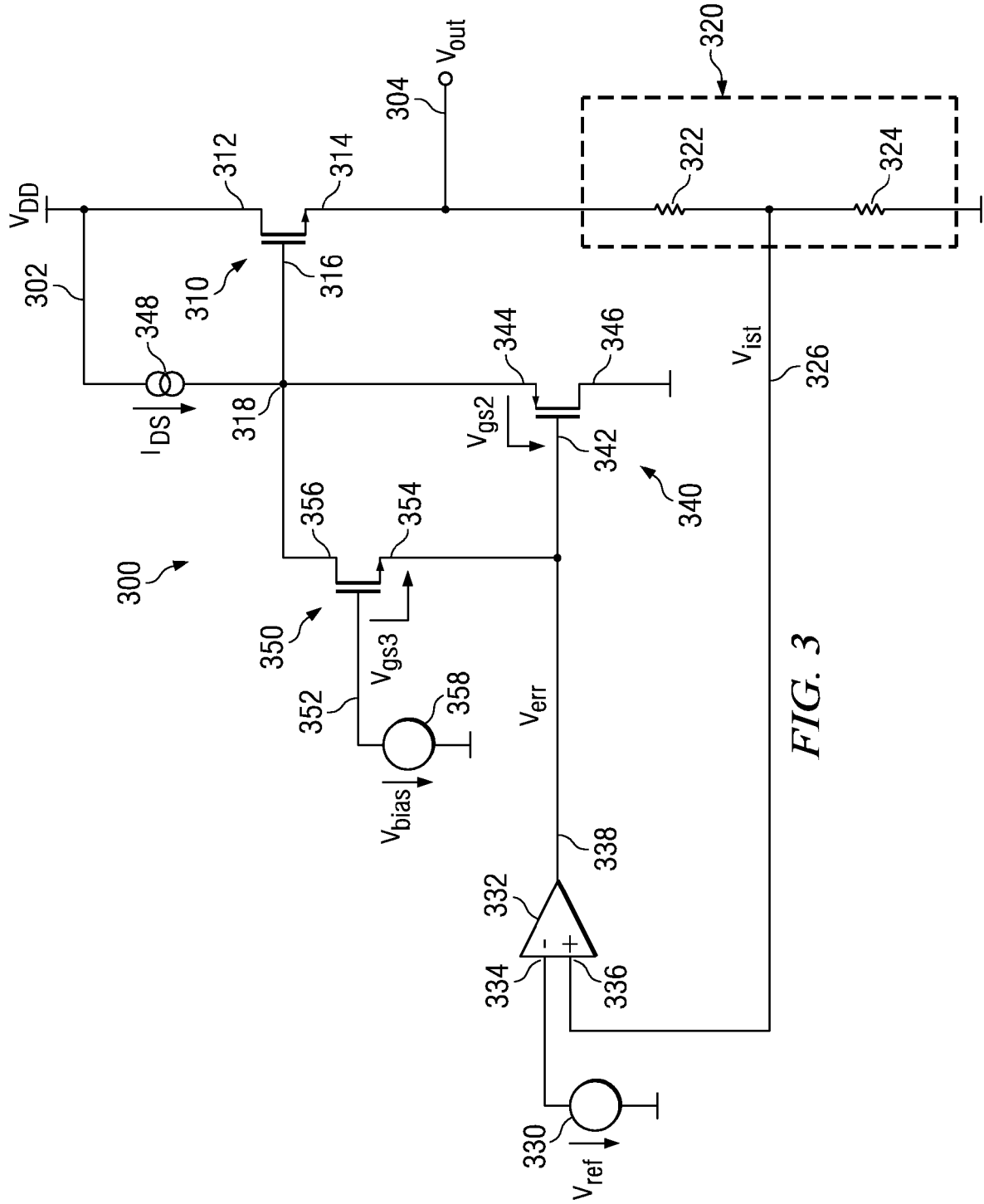

FIG. 3

VOLTAGE REGULATOR WITH LOW DROPOUT VOLTAGE

The invention relates to apparatus and methods for reducing the dropout voltage range in voltage regulator circuits.

BACKGROUND

The demand for voltage regulators having low dropout voltages is increasing because of the growing demand for low voltage applications of mobile electronic devices. For low voltage circuits (for example, rail-to-rail circuits or linear regulators wherein a power-MOS switch must be completely "off" at one extreme and be able to source large amounts of current at the other extreme), a high voltage swing capability is necessary for the output FET (Field-Effect Transistor) to provide an efficient regulation, that is, the output FET has to be driven within less than 500 mV of the positive supply voltage and down to within 500 mV of ground. A typical N-type source-follower, or even an N-type emitter follower, as driver for the output FET has the disadvantage of a high input-to-output voltage drop V_{gs} . A P-type follower, on the other hand, is not able to drive the output FET down close to ground. A differential amplifier in unity gain configuration may be able to drive a wider voltage range, but an extra OP-amp (operational amplifier) increases complexity, required footprint area and cost for the circuit. Further, with an OP-amp, an additional pole is introduced in the feedback loop which leads to stability problems, deteriorated speed and bandwidth performance.

SUMMARY

The invention provides a voltage regulator having low voltage dropout, with enhanced performance and stability. A bypass transistor is provided in the output voltage error control loop to extend the normal operating range of the output transistor at low voltages, beyond the previous limitation of the driving transistor gate-to-source voltage.

In described embodiments, a voltage regulator with low dropout voltage comprises a supply input terminal for connecting a supply voltage, an output terminal for providing a regulated output voltage, a reference voltage source, and an output voltage monitor. An error amplifier has a first input connected to the reference voltage source, a second input connected to the output voltage monitor and an output supplying an error signal in response to deviations of the regulated output voltage from a desired target output voltage at the output terminal of the voltage regulator. A power output FET, has a gate terminal and a drain-source channel connected between the supply input terminal and the output terminal of the voltage regulator. The regulator further comprises a driver FET, having a gate terminal connected to the control output of the error amplifier, a drain or source terminal connected to ground and a source or drain terminal connected to the gate of the power output FET. A current source supplies a drain-source current for the driver FET. The gate terminal of the power output FET is controlled by the error amplifier via the driver FET in such a way that any deviations of the regulated output voltage from a desired target output voltage value are minimized. In accordance with an aspect of the invention, a bypass FET has a source or drain terminal connected to the gate terminal of the driver FET, a drain or source terminal connected to the source or drain terminal of the driver FET, and a gate terminal connected to a bias voltage source. The bias voltage source provides a bias voltage set to switch the bypass FET on and

bypass the gate-source junction of the driver FET when the gate-to-source voltage of the driver FET becomes a limitation to maintaining normal operation of output voltage regulation.

In one example, the regulator comprises a driver FET of a p-conductivity type, having a gate terminal connected to the control output of the error amplifier, a drain terminal connected to ground and a source terminal connected to the gate of the power output FET. A current source supplies a drain-source current for the driver FET and is connected between the supply input terminal and the source terminal of the driver FET. A bypass FET of an n-conductivity type has a source terminal connected to the gate terminal of the driver FET, a drain terminal connected to the source terminal of the driver FET, and a gate terminal connected to a bias voltage source. The bias voltage source provides a bias voltage which is determined such that the bypass FET begins conducting when the source voltage of the driver FET cannot be further reduced towards the drain potential by application of the error signal to its gate, due to the inherent gate-source voltage drop of the driver FET. The conducting bypass FET bypasses the gate-source junction of the driver FET, allowing the error amplifier to drive the gate of the output FET even further down towards the drain potential. Thus, the driving range for the gate of the output FET is not narrowed by the gate-source voltage of the driver FET.

The invention thus provides a voltage regulator with a low dropout voltage and an extended normal operating range. The output of the regulator can be driven from near ground up to near the supply voltage. The invention combines the high output voltage swing and low output impedance capability of a p-type source-follower with the low output voltage capability of a source-grounded n-type FET. Implementation of the suggested circuit requires only very few components. As a result, the circuit has low power consumption and high error efficiency, while the circuit can be manufactured at low cost.

In an alternative embodiment, a low dropout voltage regulator comprises a supply input terminal for connecting a supply voltage, an output terminal for providing a regulated output voltage, a reference voltage source, and an output voltage monitor. An error amplifier has a first input connected to the reference voltage source, a second input connected to the output voltage monitor and an output supplying an error signal in response to deviations of the regulated output voltage from a desired target output voltage at the output terminal of the voltage regulator. A power output FET, has a gate terminal and a drain-source channel connected between the supply input terminal and the output terminal of the voltage regulator. The regulator further comprises a driver FET of an n-conductivity type, having a gate terminal connected to the control output of the error amplifier, a drain terminal connected to the supply input terminal and a source terminal connected to the gate of the power output FET. A current source supplies a drain-source current for the driver FET and is connected between the source terminal of the driver FET and ground. The gate of the power output FET is controlled by the error amplifier via the driver FET in such a way that any deviations of the regulated output voltage from a desired target output voltage value are minimized. A bypass FET of a p-conductivity type, has a source terminal connected to the gate terminal of the driver FET, a drain terminal connected to the source terminal of the driver FET, and a gate terminal connected to a bias voltage source. The bias voltage source provides a bias voltage which is determined such that the bypass FET begins conducting when the source voltage of the driver FET

cannot be further raised towards the drain potential by application of the error signal to its gate, due to the inherent gate-source voltage drop of the driver FET. The conducting bypass FET bypasses the gate-source junction of the driver FET, allowing the error amplifier to drive the gate of the output FET even further up towards the drain potential. Thus, the driving range for the gate of the output FET is not narrowed by the gate-source voltage of the driver FET. So, the low drop voltage regulator according to the invention provides an extended operating range.

BRIEF DESCRIPTION OF THE DRAWINGS

Further advantages and features of the invention will become apparent from the following detailed description with reference to the appended drawings. In the drawings:

FIG. 1 shows a schematic circuit according to a first embodiment of the invention;

FIG. 2 shows a schematic circuit according to a second embodiment of the invention;

FIG. 3 shows a schematic circuit according to a third embodiment of the invention; and

FIG. 4 shows a schematic circuit according to a fourth embodiment of the invention.

DETAILED DESCRIPTION OF EXAMPLE EMBODIMENTS

The low dropout voltage regulator **100** illustrated in FIG. 1 has an input terminal **102** for connecting the circuit to a supply voltage V_{DD} and an output terminal **104** to provide an output voltage V_{out} . A PMOS output FET **110**, has a source terminal **112**, a drain terminal **114** and a gate terminal **116**. The source terminal **112** is connected to the supply voltage terminal **102**, the drain terminal **114** is connected to the output terminal **104** and the gate terminal **116** is connected to a node **118**.

A voltage divider comprising resistors **122** and **124**, serially connected between the output terminal **104** and ground, constitutes a voltage monitor **120**, providing at a tap terminal **126** a monitor voltage V_{ist} proportional to the output voltage V_{out} .

A reference voltage source **130** provides a reference voltage V_{ref} . An error amplifier **132** has a first input **134** connected to the voltage reference **130**, a second input **136** connected to the tap terminal **126** of the voltage monitor **120**, and an output **138**. The error amplifier **132** compares the actual voltage V_{ist} with the reference voltage V_{ref} and delivers at the output **138** a control voltage V_{err} for controlling the output FET **110**.

A PMOS driver FET **140** has a gate terminal **142** connected to the output **138** of the error amplifier **132**, a source terminal **144** connected to the node **118** and a drain terminal **146** connected to ground. A current source **148**, connected between the input terminal **102** and the source terminal **144** of the driver FET **140** provides a drain-source current I_{DS} for the driver FET **140**.

A bypass FET **150**, which is an NMOS FET, has a gate terminal **152**, a source terminal **154** and a drain terminal **156**. The drain terminal **152** is connected to node **118**, and the source terminal **154** is connected to the gate terminal **142** of the driver FET **140**. A voltage source **158** provides a bias voltage V_{bias} for the gate terminal **152** of the bypass FET **150**.

The operation of the voltage regulating circuit **100** is as follows:

The output FET **110** can be controlled via its gate terminal **116** to provide a regulated desired output voltage V_o at the output terminal **104**. Deviations of the actual output voltage V_{out} from the desired output voltage V_o due to load current swing caused by a load connected to the output terminal **104** or due to alterations in the supply voltage V_{DD} are monitored by the output voltage monitor **120**. The output voltage monitor **120** delivers a monitoring voltage V_{ist} proportional to the actual output voltage V_{out} .

A deviation in the output voltage V_{out} causes the error amplifier **132** to adapt the control voltage V_{err} in order to control the output FET **110** via the driver FET **140** in such a way that any deviations of the regulated output voltage V_{out} from the desired target output voltage V_o are minimized. If the actual output voltage V_{out} drops due to an increased load at the output **104**, the control voltage V_{err} will be reduced, and the driver FET **140** will drive the gate **116** of the output FET **110** down towards the drain potential. Therefore, the output FET **110** will increase current supply to the output **104** and the actual output voltage V_{out} will rise until the desired output voltage V_o is achieved. Increased demand for current from the supply, of course, causes a drop in the supply voltage V_{DD} .

As long as the output FET **110** can be driven by the driver FET **140** to supply enough current to the output to keep the output voltage V_{out} at the desired output voltage level V_o , the regulator **100** operates in a regulating load-current range. In this normal operating range, the regulator provides at its output a stable output voltage which is independent of the input voltage.

However, there is a limit for driving the gate **116** of the output FET **110**. Due to its inherent gate-source voltage V_{gs2} , the driver FET **140** cannot drive the gate **116** of the output FET **110** further towards the potential of the drain terminal than V_{gs2} above ground. At this point, the regulator has reached the end of the regulating load-current range and the potential difference between the supply voltage and the output voltage has reached its minimal value, which is defined as the "dropout" voltage. If the load current increases further or if the supply voltage drops further, the regulator can no longer maintain the desired output voltage level V_o . The regulator then enters the dropout range. In this dropout range, any further drop of the supply voltage leads to a drop in the output voltage.

In the proposed circuit, a bypass FET **150** is provided to bypass the gate-source junction of the driver FET **140** when the regulator is about to enter the dropout range. To this end, the bias voltage V_{bias} is determined to define a threshold voltage $V_{tr} = V_{bias} - V_{gs3}$, where V_{gs3} is the gate-source voltage of the bypass FET **150**. The bias voltage V_{bias} is determined so that the bypass FET **150** begins conducting when the source voltage of the driver FET **140** cannot be further reduced by application of the error signal V_{err} to its gate towards the drain potential, due to the inherent gate-source voltage drop V_{gs2} of the driver FET **140**. So, when the control voltage V_{err} drops below this threshold voltage V_{tr} , the bypass FET **150** starts conducting current and the bypass FET **150** gradually bypasses the gate-source junction of the driver FET.

Thus, node **118**, which is connected to the gate of the output PMOS FET **110**, can be pulled further towards ground. As a result, the dropout voltage of the regulator is reduced and the regulating load-current range is extended.

FIG. 2 shows a low dropout voltage regulator circuit **200** according to an alternative embodiment of the invention.

The arrangement of circuit **200** is similar to that of circuit **100** of FIG. **1**, described above. Therefore, corresponding elements are given corresponding reference numerals, augmented by **100**.

The primary difference from the previously described regulator circuit **100** is that the driver FET **240** and the bypass FET **250** are of an opposite conductivity type to the corresponding elements **140** and **150** in FIG. **1**. In the FIG. **2** arrangement, the driver FET **240** is an NMOS FET, having its drain terminal **246** connected to the input voltage terminal **202**, its source terminal **244** connected to the node **218** and its gate terminal **242** connected to the output **238** of the error amplifier **232**. The drain source current I_{DS} for the driver FET **240** is supplied by current source **248** connected between the node **218** and ground. The bypass FET **250** is a PMOS FET, having its source terminal **254** connected to the gate terminal **242** of the driver FET **240**, its drain terminal **256** connected to the node **218** and its gate terminal **252** connected to the bias voltage source **258**.

The function of the regulator circuit **200** is similar to the function of the circuit **100**, described above. In the regulating load-current range, deviations of the output voltage V_{out} from the desired output voltage V_o are monitored by the output voltage monitor **220** and cause the error amplifier **232** to provide a control voltage V_{err} to control the output FET **210** via the driver FET **240**. When the actual output voltage V_{out} drops, the error amplifier will raise the control voltage V_{err} to drive the gate **216** of the output FET **210** towards ground via the driver NMOS FET **240**.

The driver FET **240** can drive the gate of the output FET **210** to ground but not closer to the supply voltage than $V_{DD}-V_{gs2}$. The bias voltage source provides a voltage V_{bias} determined such that the bypass FET **250** begins conducting when the source voltage of the driver FET **240** cannot be further raised by application of the error signal V_{err} to its gate towards the drain potential, due to the inherent gate-source voltage drop V_{gs2} of the driver FET **240**. So, the bypass FET **250** can shunt the gate-source voltage V_{gs2} of the driver FET **240**, allowing the error amplifier **232** to drive node **218** and thus the gate **216** of the output PMOS FET **210** closer to the input supply voltage V_{DD} . Thus, the invention extends the range for the regulating load-current range.

FIG. **3** shows a low dropout voltage regulator circuit **300** according to another alternative embodiment of the invention. The circuit **300** is also similar to the circuit in FIG. **1**, described above. Therefore, like reference numerals augmented by **200** are used for components corresponding to those already described.

In this embodiment, the output FET **310** is an NMOS FET. The PMOS driver FET **340** is connected between the node **318** and ground. The current source **348**, connected between the input terminal **302** and the source terminal **346** of the driver FET **340** provides a drain-source current I_{DS} for the driver FET **340**.

Deviations of the output voltage V_{out} from the desired output voltage V_o are monitored by the output voltage monitor **320** and cause the error amplifier **332** to provide a control voltage V_{err} to control the output FET **310** via the driver FET **340**. When the actual output voltage V_{out} rises, the error amplifier will lower the control voltage V_{err} to drive the gate **316** of the output FET **310** towards ground via the driver NMOS FET **340**.

The bypass NMOS FET **350** begins conducting when the source voltage of the driver FET **340** cannot be further reduced by application of the error signal V_{err} to its gate towards the drain potential, due to the inherent gate-source voltage drop V_{gs2} of the driver FET **340**. So, when the

control voltage V_{err} drops below this threshold voltage V_{tr} , the bypass FET **350** starts conducting current and the bypass FET **350** gradually bypasses the gate-source junction of the driver FET.

FIG. **4** shows a low dropout voltage regulator circuit **400** according to yet another alternative embodiment of the invention. The circuit **400** is similar to the circuit in FIG. **2**, described above. Therefore, like reference numerals augmented by **200** are used for components corresponding to those already described.

In this embodiment, unlike the PMOS output FET **210** of FIG. **2**, the output FET **410** is an NMOS FET. The NMOS driver FET **440** is connected between the supply voltage V_{DD} and the node **418**. The current source **448**, connected between the source terminal **446** of the driver FET **440** and ground, provides a drain-source current I_{DS} for the driver FET **440**.

Deviations of the output voltage V_{out} from the desired output voltage V_o are monitored by the output voltage monitor **420** and cause the error amplifier **432** to provide a control voltage V_{err} to control the output FET **410** via the driver FET **440**. When the actual output voltage V_{out} drops, the error amplifier will raise the control voltage V_{err} to drive the gate **416** of the output FET **410** towards V_{DD} via the driver NMOS FET **440**.

The bypass NMOS FET **450** begins conducting in the dropout range, when the source voltage of the driver FET **440** cannot be further raised by application of the error signal V_{err} to its gate towards the drain potential V_{DD} , due to the inherent gate-source voltage drop V_{gs2} of the driver FET **440**. So, when the control voltage V_{err} drops below the threshold voltage V_{gs2} the bypass FET **450** starts conducting current and the bypass FET **450** gradually bypasses the gate-source junction of the driver FET. In this way, the regulating load-current range is extended.

The suggested circuits provide enhanced area and power efficiency at low cost, which can be implemented in most fabrication technologies, for example, CMOS, BiCMOS as well as more modern technologies.

Those skilled in the art to which the invention relates will appreciate that the foregoing described embodiments are merely representative examples and that other embodiments can be developed within the scope of the claimed invention.

The invention claimed is:

1. A low dropout voltage regulator comprising:
 - a supply input terminal for connecting a supply voltage and an output terminal for providing a regulated output voltage;
 - a reference voltage source;
 - an output voltage monitor;
 - an error amplifier having a first input connected to the reference voltage source, a second input connected to the output voltage monitor, and an output supplying an error signal in response to deviations of the regulated output voltage from a desired target output voltage value at the output terminal;
 - a power output FET, having a gate terminal and a drain-source channel connected between the supply input terminal and the output terminal of the voltage regulator;
 - a driver FET of a p-conductivity type, having a gate terminal connected to the control output of the error amplifier, a drain terminal connected to ground and a source terminal connected to the gate of the power output FET; and
 - a current source (**148**; **348**) supplying a drain-source current (I_{DS}) for the driver FET (**140**; **340**), connected

7

between the supply input terminal (102; 302) and the source terminal (144; 344) of the driver FET (140; 340);

the gate terminal of the power output FET being controlled by the error amplifier via the driver FET in such a way that any deviations of the regulated output voltage from a desired target output voltage value are minimized;

the regulator further comprising:

a bypass FET of an n-conductivity type, having a source terminal connected to the gate terminal of the driver FET, a drain terminal connected to the source terminal of the driver FET, and a gate terminal connected to a bias voltage source, said bias voltage source providing a voltage determined such that the bypass FET begins conducting when the source voltage of the driver FET cannot be further reduced towards the drain potential by application of the error signal to its gate, due to the inherent gate-source voltage drop of the driver FET.

2. The voltage regulator of claim 1, wherein the power FET is a PMOS FET, having a source terminal connected to the supply input terminal, and a drain terminal connected to the output terminal of the voltage regulator.

3. A low dropout voltage regulator comprising:

a supply input terminal for connecting to a supply voltage and an output terminal for providing a regulated output voltage;

a reference voltage source;

an output voltage monitor;

an error amplifier having a first input connected to the reference voltage source, a second input connected to the output voltage monitor, and an output supplying an error signal in response to deviations of the regulated output voltage from a desired target output voltage value at the output terminal;

8

a power output FET having a gate terminal and a drain-source channel connected between the supply input terminal and the output terminal of the voltage regulator;

a driver FET of an n-conductivity type, having a gate terminal connected to the control output of the error amplifier, a drain terminal connected to the supply input terminal and a source terminal connected to the gate of the power output FET; and

a current source supplying a drain-source current for the driver FET, connected between the source terminal of the driver FET (240; 440) and ground;

the gate terminal of the power output FET being controlled by the error amplifier via the driver FET in such a way that any deviations of the regulated output voltage from a desired target output voltage value are minimized;

the regulator further comprising:

a bypass FET of a p-conductivity type, having a source terminal connected to the gate terminal of the driver FET, a drain terminal connected to the source terminal of the driver FET, and a gate terminal connected to a bias voltage source, said bias voltage source providing a voltage determined such that the bypass FET begins conducting when the source voltage of the driver FET cannot be further raised towards the drain potential by application of the error signal to its gate, due to the inherent gate-source voltage drop of the driver FET.

4. The voltage regulator of claim 3, wherein the power FET is a PMOS FET, having a source terminal connected to the supply input terminal, and a drain terminal connected to the output terminal of the voltage regulator.

* * * * *