

LONG-LASTING, SELF-SUSTAINING, AND ENERGY-HARVESTING SYSTEM-IN-PACKAGE (SiP)

WIRELESS MICRO-SENSOR SOLUTION

Erick O. Torres¹ and Gabriel A. Rincón-Mora¹

Abstract

As microelectronic portable devices, such as environmental and structural micro-sensors, continue to shrink and incorporate increasingly more functions, energy and power become scarce, thereby shortening operation life. Furthermore, stored energy in state-of-the-art, chip-compatible micro-battery technologies, like micro-fuel cells and thin-film lithium-ion batteries, is constrained by the limited volume space available in a microchip. For long-lasting operation life, it is therefore necessary to replenish continuously part or all of the energy consumed. The objective of this research is to harness, store, and deliver energy from the environment *in situ*, i.e., in the package, alongside the application electronics, serving as a quasi-infinite source of energy. Operation life would ultimately be independent of energy storage limitations and dependent only on the wear-and-tear of the system. The self-contained, system-in-package (SiP) solution proposed is composed of three different energy-harvesting sources, a storage device, charging and regulation circuitry, and a sensor load application. Light, vibrations, and thermal gradients provide the useful ambient energy necessary to sustain the system and an integrated battery charger transfers it to storage, into an in-package, thin-film lithium-ion battery. The energy is harvested in small, intermittent “bursts,” which is why the charger must wait until enough energy is accumulated in a transitional capacitor before transferring it to the micro-battery. Since only a finite amount of energy is delivered, the load application must consume little power and a

¹Georgia Tech Analog and Power IC Design Lab, School of Electrical and Computer Engineering, Georgia Institute of Technology, 777 Atlantic Drive, Atlanta, GA 30332-0250 Phone:(404) 894-1299
E-mails: ertorres@ece.gatech.edu, rincon-mora@ieee.org, <http://www.rincon-mora.com>

time-division multiplex approach is therefore adopted, where the system is power-moded into various operational modes to consume power only when needed and in finite bursts.

Keywords: Energy harvesting, lithium-ion battery charger, micro-sensor, system-in-package, and SiP.

I. Introduction

In today's high-tech world, microelectronic portable devices such as biomedical, military, structural, and environmental wireless micro-sensors incorporate numerous functions and therefore impose increasingly stringent power requirements on the system, in spite of every effort to limit the amount of energy required per function. Unfortunately, because of the volume constraints of portable electronics, the available, stored energy is limited, resulting in short operation life (i.e., short lifetime or runtime) (Russ). To prolong the life of the device, the system must be managed efficiently, minimizing all power losses and eliminating unnecessary or redundant battery-draining events. In addition to designing a system with high power efficiency, researchers also seek to increase the energy density in batteries, but even at the fundamental limits, the solution has low and finite lifetimes. A long-lasting energy supply, independent of the amount of energy initially stored, is still attractive and increasingly demanded in applications like biomedical implantable devices and structural-embedded systems, which is why a self-renewable energy reservoir that can continually self-replenish the energy that is consumed finds a niche in a wide variety of portable applications.

But how can this replenishing energy be harnessed from the surrounding environment and stored *in situ*? State-of-the-art micro-electromechanical system (MEMS) generators and transducers can extract energy from vibrations, thermal gradients, and even light exposure

(Roundy, 2004a). The energy extracted can then be stored in chip-compatible, rechargeable batteries such as thin-film lithium ion (Linden; Bates). However, this extracted energy is generally small and unpredictable, in the form of short intermittent bursts. It is therefore important to develop the electronics necessary to transfer this energy into the rechargeable battery and deliver it to the system without itself requiring much power to operate.

The proposed system solution harvests and transfers energy from photovoltaic, thermoelectric, and other MEMS generators to a rechargeable thin-film lithium-ion (Li-Ion) battery, resulting in a long-lasting, self-sustaining microelectronic system capable of self-replenishing its own energy drain. Since harvested energy manifests itself in irregular, random “bursts,” a discontinuous, intermittent charger is required to interface the energy-sourcing devices with the energy-storage reservoirs (e.g. lithium-ion batteries). The charger must harness sporadic trickles of energy supplied by the surroundings, convert them into usable power, and use them to charge a Li-Ion battery. Energy that is typically lost in the environment is therefore added back to the system, thereby decreasing or even eliminating the need for battery replacement and/or external recharge cycles. The goal of this project is to design an intermittent micro-power CMOS Li-Ion charger and integrate it with chip-compatible energy-harvesting and storage elements and micro-sensor device into a single plastic chip-package, resulting in a long-lasting, self-sustainable system-in-package (SiP) micro-sensor solution.

II. Background

Present-day technologies can scavenge vibrational, thermal, and solar energy from the environment. For the proposed self-harnessing system, this energy must then be stored in capacitors, batteries, and other electrochemical reservoirs. However, transferring this energy from its

source to the storage devices must not only cater to the reservoir but also itself incur insignificant power losses. What is more, for a system-in-package (SiP) solution, all of these components must somehow conform to the constraints of a silicon chip-package, in other words, they must all live and coexist in the same chip.

A. Energy Harvesting

Energy harvesting is defined as the conversion of ambient energy into usable electrical energy. When compared with the energy stored in common storage elements like batteries, the environment represents a relatively inexhaustible source of energy. Consequently, energy harvesting (i.e., scavenging) methods must be characterized by their power density, rather than energy density. Table 1 compares the estimated power and challenges of various ambient energy sources. Light, for instance, can be a significant source of energy, but it is highly dependant on the application and how much exposure the device is subjected to (e.g., indoors versus outdoors). Thermal energy, on the other hand, is limited because the gradients across a chip are typically low. Vibrational energy is a moderate source, but again dependent on the application. A stationary outdoor sensor may therefore benefit from harnessing light energy but a navigational indoor sensor may better reap the advantages of systematic vibrations.

Energy Source	Challenge	Estimated Power (in 1 cm^3 or 1 cm^2)
Light	Conform to small surface area	$10 \mu\text{W} - 15 \text{ mW}$ (Outdoors: $0.15 - 15 \text{ mW}$) (Indoors: $<10 \mu\text{W}$)
Vibrations	Variability of vibration	$1 - 200 \mu\text{W}$ (Piezoelectric: $\sim 200 \mu\text{W}$) (Electrostatic: $50 - 100 \mu\text{W}$) (Electromagnetic: $< 1 \mu\text{W}$)
Thermal	Small thermal gradients	$15 \mu\text{W}$ ($10 \text{ }^\circ\text{C}$ gradient)

Table 1. Comparison between different ambient energy sources.

Vibration Energy: Energy extraction from vibrations is based on the movement of a “spring-mounted” mass relative to its support frame, when it experiences acceleration (Roundy, 2003), as shown in Figure 1. Mechanical acceleration is produced by vibrations that in turn cause the mass component to move and oscillate (kinetic energy). This relative displacement causes opposing frictional and damping forces to be exerted against the mass, thereby reducing and even extinguishing the oscillations. The damping forces literally absorb (i.e., harness) the kinetic energy of the initial vibration to suppress the oscillation. This harnessed energy can be converted into electrical energy via an electric field (electrostatic), magnetic field (electromagnetic), or strain on a piezoelectric material. The energy-conversion procedure represents a kinetic energy loss (i.e., energy is transferred) and it is therefore regarded as electrical damping and, in this case, energy harvested from the surrounding environment.

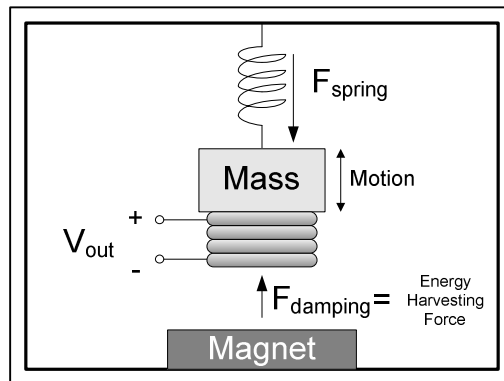

Figure 1. Electromagnetic vibration energy harvester.

Irrespective of the means, the energy harvested from vibrations is constrained by various characteristics. For instance, the system extracts maximum energy when it is at resonance with the ambient vibrations. Furthermore, the extracted energy is inversely proportional to frequency

and directly proportional to oscillating mass. In fact, maximum energy is extracted when mechanical and electrical damping energies are equal.

Most sources of vibrations in the environment are at low frequencies, typically between 60 and 200 Hz (Roundy, 2003, 2004a). This situation is, on one hand, beneficial because, as stated earlier, power extracted is inversely proportional to frequency, but on the other hand, since maximum energy is extracted when the oscillating mass component is at resonance with the ambient vibrations, a low frequency oscillating structure is required, and mechanical resonance of a structure increases as its dimensions decrease. Consequently, low resonant frequencies may be difficult to achieve in micro-scale devices. An oscillating cantilever beam design provides the lowest resonance frequency for any given size and is therefore the most appropriate solution for chip-compatible systems (Roundy, 2003; 2004b).

Placing and fabricating a large mass in a micro-system is also another limitation. Large masses are difficult to realize in micro-scale spaces, thereby limiting the amount of energy that can be extracted. Power is maximized when mechanical and electrical damping coefficients are low and matched, but low coefficients are not compatible with small spaces. The electrical damping coefficient is a function of circuit parameters and the energy conversion mechanism employed, and it is typically designed to be close or slightly above the mechanical damping factor. Mechanical damping, on the other hand, such as air friction, can be reduced in a vacuum with up to a four-fold increase in scavenged power, but at the expense of added fabrication complexity and cost (Williams, 2001). Moreover, low damping values cause greater oscillating mass displacement, thereby requiring more space, which is a luxury that cannot be afforded in a single chip solution. As a result, damping energy is limited by the physical constraints of the oscillating

structure, and harnessed power from vibration is therefore also limited to typically less than 200 μW (Roundy, 2003).

Electromagnetic energy harvesting from vibrations uses a magnetic field to convert mechanical energy to electrical (Amirtharajah; Kulah; El-Hami; Williams, 1996). The method exploits Faraday's law, which states that a voltage is produced as the magnetic flux of a magnetic field changes. In such a harvesting system, a coil is attached to the oscillating mass and moves through a magnetic field that is established by a stationary and permanent magnet (Figure 1). As the coil moves along with the vibrations, it travels through a varying amount of magnetic flux, inducing a voltage on the coil. Given the small amplitude of the vibrations, the induced voltage is inherently small and must therefore be increased to be a viable solution. Methods to increase the induced voltage include using a transformer, increasing the number of turns of the coil, and/or increasing the permanent magnetic field. However, all options are limited by the size constraints of a microchip.

Piezoelectric energy harvesting converts mechanical energy to electrical by straining a piezoelectric material (Roundy, 2003, 2004b; Sodano, 2004a, 2004b; Ottman, 2002, 2003). Strain, or deformation, in a piezoelectric material causes charge separation across the device, producing an electric field and consequently a voltage drop proportional to the stress applied. The effectiveness of the conversion is dependent on the mechanical-to-electrical coupling of the material, i.e., its piezoelectric properties. The oscillating system is typically a cantilever beam structure with a mass at the unattached end of the lever (Figure 2a), since it provides higher strain and lower resonance for a given input force (Roundy, 2003, 2004b). Higher strain is achieved with long, thin cantilever structures; however, less mass can be supported, resulting in less power.

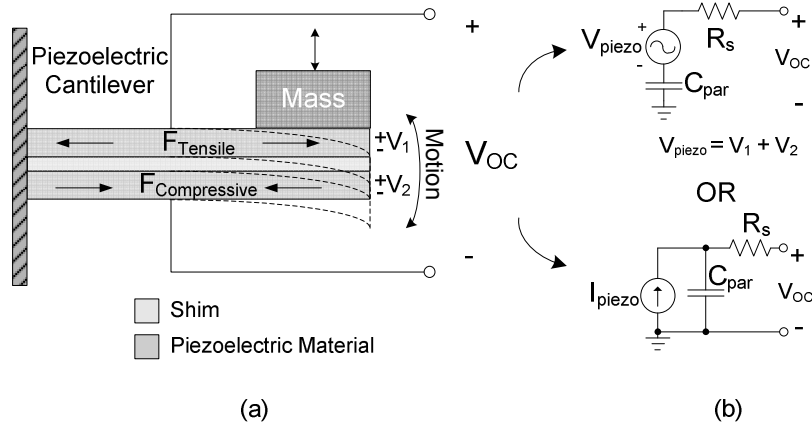

Figure 2. (a) Piezoelectric “bimorph” beam and its (b) Thevenin and Norton equivalent circuit models.

The beam is constructed as a two-layer bender “bimorph” structure with two sheets separated by a center shim. Both layers are polarized so that either their voltages or charges add. The voltage produced will vary with time and strain, effectively producing an irregular ac signal, whose magnitude is dependent on vibration levels. Thus, the piezoelectric cantilever is modeled as an ac voltage source, as shown in Figure 2b. The series capacitance and resistance model the capacitance across the shim and the electrical conductivity of the piezoelectric material. The Norton equivalent model is also shown, in which case an ac current source is used instead of the voltage source.

A drawback to piezoelectric converters is the additional circuitry required to rectify and convert the extracted power from an unsteady, high impedance source to a stable, low impedance supply. The supplementary circuitry incurs additional power losses and therefore decreases the overall effectiveness and efficiency of the conversion mechanism. Another shortcoming to this technique is that thin-film piezoelectric materials compatible with microfabrication processes

have reduced mechanical-to-electrical coupling, which limits its power output. What is more, they are more brittle and can only support small masses. Nevertheless, piezoelectric energy conversion produces relatively better voltage levels with higher power density than the electromagnetic system.

Electrostatic (capacitive) energy harvesting schemes rely on the changing capacitance of vibration-dependant varactors (Meninger; Roundy, 2002, 2003; Stark) – Figures 3a and 3b. A varactor (variable capacitor) is initially charged, and as its plates separate because of vibrations, mechanical energy is transformed into electrical energy. The conversion is achieved through two different mechanisms, by keeping either the voltage or charge constant. For instance, in the former, the voltage across the variable capacitor is held constant as its capacitance changes after an initial charge. Therefore, as the plates separate and capacitance C decreases, charge Q must be driven out of the device ($Q = CV_{\text{Constant}}$), which can then be stored in a reservoir or used to charge the battery generating the voltage source. The remaining charge is then recovered while capacitance is at its minimum. In other words, vibration forces charge to flow into and out of the capacitor. Some mechanism is required to maintain the voltage constant, which requires another source in addition to the initial charge source. Consequently, this method is more suitable for a dual rail-supply system.

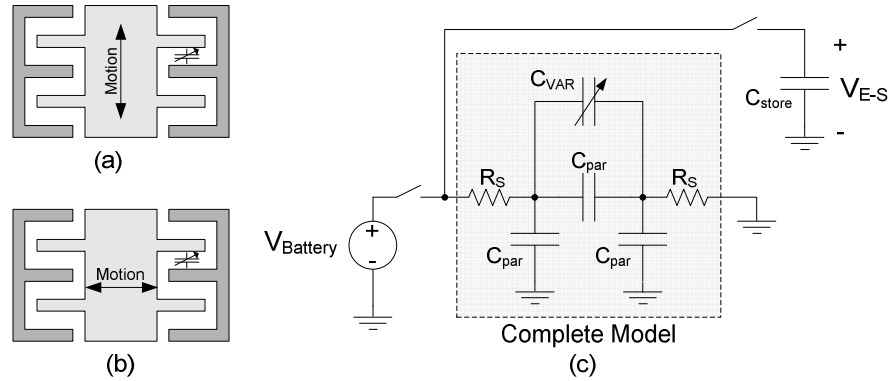

Figure 3. (a) Gap and (b) overlap in-plane variable capacitors, and (c) an energy harvesting circuit highlighting the model of the variable capacitor.

A more practical approach is the constant charge technique, where the capacitor is open-circuited, constraining the charge in the capacitor and therefore forcing the voltage to change accordingly – Figure 3c. As the plates separate and the capacitance C decreases, the voltage and energy stored in the capacitor increase ($Q_{\text{Constant}} = CV$). Precise synchronization with the vibration frequency is required to ensure the capacitor is charged at its maximum capacitance and discharged at its minimum capacitance point, which implies the voltage and energy only increase with vibration. Care must be taken to transfer the energy to a storage capacitor exactly when capacitance is at a minimum, and voltage is at its maximum points; otherwise, energy conversion is not maximized. Overall, the voltage-constrained scheme harvests more power than the charge counterpart, but the latter only requires a single voltage source, which is an overriding factor to consider.

The most attractive feature of electrostatic energy harvesting is its IC-compatible nature. MEMS variable capacitors are typically fabricated through relatively mature silicon micro-machining techniques, such as deep reactive ion etching (DRIE). The movement of the capacitor plate is preferably in-plane (in parallel) with the substrate to avoid problems associated with out-

of-plane capacitors, such as large mechanical damping and surface interactions. The capacitor plates for in-plane motions are typically fabricated with inter-digitated fingers in a comb structure. The change in capacitance induced by vibrations can be caused by either variations in the dielectric gap distance or overlap area, each shown in Figures 3a and 3b. Better stability and greater capacitance differentials (~ 780 pF) are achieved with changing gap distance. Overlap capacitors have greater Q-factor, and thus better theoretical power extraction capability, but suffer from stability problems, smaller capacitance differentials (~ 270 pF), and greater parasitic capacitance (Roundy 2003). Parasitic capacitors develop between the moving plate and the substrate and sidewalls, which limit the maximum allowable voltage, since these are in parallel and hold voltage constant, and in turn constraint the output power. Moreover, because of parasitic capacitors, more initial charge is required. The complete electrical model of the variable capacitor in a charge-constrained harvesting circuit is illustrated in Figure 3c.

Electrostatic conversion is the most chip-compatible scheme, when compared to all vibration energy conversion methods. It also produces higher and therefore better output voltage levels than the electromagnetic method, with moderate power density. Maximum energy is extracted when the capacitance changes the most, which is achieved by reducing the gap distance between opposing fingers and lengthening each finger in the comb structure.

Thermal Energy: Thermal gradients in the environment are directly converted to electrical energy through the Seebeck (thermoelectric) effect (Castano; DiSalvo; Fleurial; Rowe; Scherrer; Stordeur; Wang). Temperature differentials between opposite segments of a conducting material result in heat flow and consequently charge flow, since mobile, high-energy carriers diffuse from high to low concentration regions. As carriers diffuse, a concentration gradient produces an elec-

tric field across the material that opposes the net diffusion of carriers, eventually forcing equilibrium conditions. At equilibrium, the carriers traveling back to the high temperature junction due to the electric field cancel the net number of hot carriers traveling towards the cold junction, and therefore, no voltage is established.

A thermocouple configuration is a more suitable approach for power generation. This type of configuration consists of n- and p-type materials electrically joined at the hot end (Figure 4). Heat flow carries the dominant charge carriers of each material (electrons in n-type and holes in p-type) to the low temperature junction, respectively ionizing each base electrode with an opposite charge and therefore establishing a voltage differential across the low temperature base electrodes. As charge carriers depart the hot end, they leave behind ionized molecules that, instead of attracting the opposite flow of charge from the material itself, attract carriers from the opposite type material through a metallic, low impedance short. Electron carriers, for instance, continually move from the p- to n-type material to de-ionize a molecule, at which point they absorb thermal energy, jump to a higher energy state, and continue to flow to the low temperature junction. In the end, the generated voltage and power is proportional to the temperature difference and the Seebeck coefficient of the thermoelectric materials.

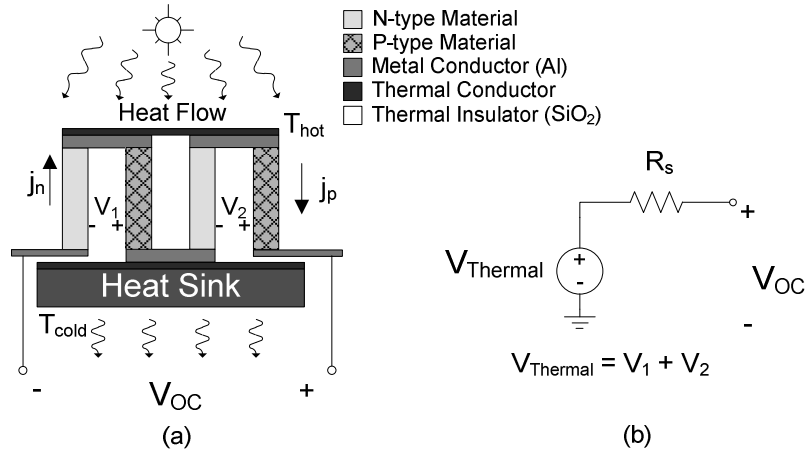

Figure 4. (a) Thermoelectric energy converter composed of two series thermocouples and (b) its circuit model.

Large thermal gradients are essential to produce practical voltage and power levels. Nevertheless, temperature differences greater than $10\text{ }^\circ\text{C}$ are rare in a micro-system (Roundy 2004a). Placing several thermocouple elements in a series configuration alleviates the necessity of large thermal gradients, but at the expense of large series electrical resistance. Large series resistance increases ohmic power losses, adversely affecting the overall power efficiency of the mechanism. As a result, low voltage levels are expected.

Material selection is critical to maximize voltage and power generation. Thermoelectric materials with large Seebeck coefficients effectively improve the energy conversion mechanism, producing higher voltage levels. Additionally, low thermal conductivity (high thermal impedance) maximizes heat retention at the junction and high electrical conductivity (low electrical resistance) minimizes ohmic power losses. A thermally insulating material, such as SiO_2 surrounding the device, maintains heat flow across the thermocouples and avoids heat dissipation through the substrate. Some materials typically used for thermoelectric energy conversion in-

clude Sb_2Te_3 , Bi_2Te_3 , Bi-Sb, PbTe, Si-Ge, polysilicon, BiSbTeSe compounds, and InSbTe (Fleu-rial; Castano; Kiely).

Light Energy: Photovoltaic cells convert incident light into electrical energy (Kasap; Raffaele; Warneke). Each cell consists of a reverse-biased pn^+ junction, where light interfaces with the heavily doped and narrow n^+ -region (Figure 5a). Photons are trapped within the depletion region and generate electron-hole pairs, if they have sufficient energy at the appropriate wavelength. The built-in electric field of the junction immediately separates each electron-hole pair so that electrons drift to the n^+ -side and holes to the p-side. Positive and negative charges accumulate at the p- and n^+ -side, respectively, developing an open-circuit voltage whose magnitude is depend-ent on the bandgap of the material. With a connected load across the cell, excess electrons travel through it from the n^+ -side to recombine with holes at the p-side, generating a photocurrent that is directly proportional to light intensity and independent of cell voltage.

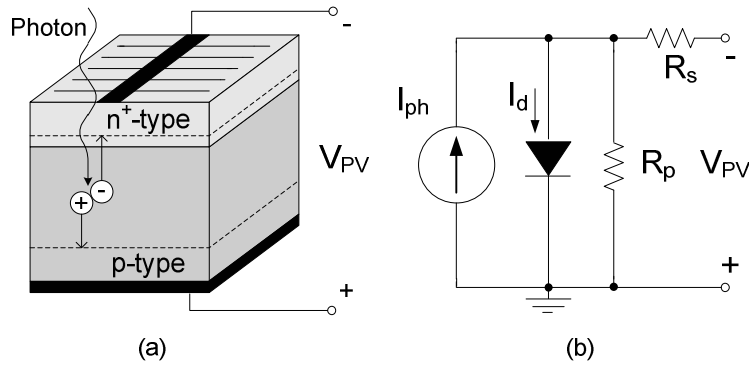

Figure 5. (a) Photovoltaic cell and (b) its circuit model.

A current source with appropriate parasitic elements models the photovoltaic cell. A shunt parasitic diode represents the pn-junction, where the load voltage determines the forward-

bias diode current. The total current delivered to the load is the difference between the generated photo-current and shunting diode current. The surface distance traveled by each generated carrier (to reach the electrode) introduces series resistance, which is why, to minimize it, one of the electrodes completely covers the dark side and numerous thin finger electrodes permeate the illuminated side without significantly impeding light flow. Figure 5b illustrates the electrical model of a photovoltaic cell with its parasitic elements, where each component unfavorably affects power delivery and cell efficiency.

Typically, micro-systems employ thin-film photovoltaic cells. Because of size constraints, a single cell cannot provide significant power and, consequently, several cells are connected in series strings (or in parallel arrays) to increase voltage (or current). Research demonstrates that thin-film photovoltaic cells can provide sufficient power to a micro-system, although at lower efficiencies than their macro-scale counterparts (Raffaello; Warneke). One cause of lower efficiency is the small area available for illumination in a micro-system. Implementing a three-dimensional (3D) diode structure geometry constructed on porous silicon helps mitigate this problem, since a larger internal surface area now exists (Sun). Overall, photovoltaic energy conversion offers higher output power levels, relative to other energy conversion mechanisms already presented, in addition of being a mature IC-compatible technology. Nevertheless, its power output is heavily dependent on environmental conditions, and changes drastically with various light intensities.

Energy Conversion Method	Advantages	Disadvantages	Challenge in Micro-system
Photovoltaic	<ul style="list-style-type: none"> • No moving parts, reliable • Mature technology • Scalable 	<ul style="list-style-type: none"> • Highly dependant on surrounding light conditions 	<ul style="list-style-type: none"> • Small surface areas
Piezoelectric	<ul style="list-style-type: none"> • No voltage source required • Higher output voltage 	<ul style="list-style-type: none"> • Difficult integration • Moving parts 	<ul style="list-style-type: none"> • Decreased coupling of thin-films
Electrostatic	<ul style="list-style-type: none"> • Scalable • Compatible with current technology 	<ul style="list-style-type: none"> • Single versus dual voltage source (charge or voltage constrained) • Moving parts 	<ul style="list-style-type: none"> • Stability
Electromagnetic	<ul style="list-style-type: none"> • No voltage source required 	<ul style="list-style-type: none"> • Very low output voltage • Moving parts 	<ul style="list-style-type: none"> • Difficulty in integrating magnet
Thermoelectric	<ul style="list-style-type: none"> • No moving parts, reliable • Scalable • Durable 	<ul style="list-style-type: none"> • Very low conversion efficiency • Low output voltage 	<ul style="list-style-type: none"> • Low temperature gradients

Table 2. Comparison between different ambient energy conversion methods.

B. Energy Storage

Fundamentally, energy harvesters are low power sources with a virtually unlimited energy supply, but their intermittent nature limits their use. As long as the system is designed to operate under low power conditions, energy-harvesting sources can satisfy its power demands. However, this may become ineffective and impractical because energy is not supplied continuously, but rather in intermittent and spontaneous spurts, and therefore not necessarily available when required. Moreover, micro-sensors must accommodate several high power functions, such as data transmission, that energy-harvesting sources cannot supply. A more practical approach is to store, when possible, converted energy in energy-storage elements capable of supplying power and energy on-demand, when needed. Typical energy-storage devices in a micro-system include capacitors, inductors, and batteries.

Passive storage elements, such as capacitors and inductors, store energy in either electric or magnetic fields, respectively. Inductors integrated in a micro-system have small inductance

values and develop weak magnetic fields because of few turns and low currents. Similarly, capacitors are small and exhibit low energy density; but on the up side, they are less susceptible to leakage and feature higher power density. Notwithstanding, capacitors and inductors are useful as intermediate, short-term energy storage devices, especially when transferring energy from its original source to a more capable energy-storage device, such as a battery.

Batteries store electrical energy chemically. Energy is released as electricity through a chemical reaction inside the battery cell that transfers electrons from its anode to its cathode across an electrolyte material (Linden). Recharging the battery reverses this reaction and stores electrical energy back in the form of chemical bonds. Conventional chemistries, such as NiZn, NiMH, and NiCd, offer high energy densities and good discharge rates, but also feature short cycle life and adverse “memory” effects. Lithium-ion (Li-ion) batteries overcome these drawbacks, with higher energy density and discharge rate, higher cell voltage, longer cycle life, and nonexistent “memory” effects. Figure 6 illustrates the natural progression from passive storage elements to lithium-ion batteries. Thin-film technology (less than 15 μm thickness) promises to permit the integration of lithium-ion batteries into a micro-system while capable of delivering relatively high power levels (Bates). A disadvantage is their sensitivity to overcharge and over-discharge. If the cell voltage increases above 4.2 V, or decreases below 2.7 V, the battery will significantly degrade, and in some cases, even vent and explode. Careful energy management during the charging and discharging processes is essential to maximally extend battery life and usable capacity.

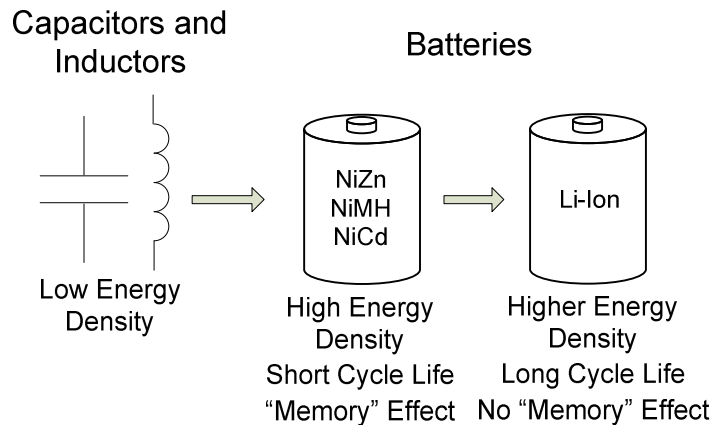

Figure 6. Energy storage elements.

C. Charging Circuitry

The charger is the interface between the energy harvester and the battery, transferring energy from source to storage. Maximum battery life, capacity, and energy content require a power efficient charger design. A constant-current/constant-voltage charging scheme achieves such purpose for lithium-ion batteries, to charge the battery for maximum usable capacity. The initial phase preconditions the battery with a low charging current, ensuring the cell is ready (voltage is at least 2.7 V) for a full charge cycle, which terminates at the end-of-charge voltage, typically around 4.2 V. During the constant-current step, charging current cannot exceed 1.5 C to avoid premature aging, electrolyte disassociation, and other damages to the cell – 1 C corresponds to the discharge current required to completely exhaust the battery in exactly one hour. To fully and safely charge the battery, when the voltage nears the end-of-charge threshold, a constant voltage is applied to the battery, effectively supplying a slowly decreasing charging current, until an end-of-charge current value is reached (typically around C/10), at which point the whole charge cycle is completed. Figure 7 shows an idealized model of the constant-current/constant-voltage charging procedure for lithium-ion batteries. For a fast charge cycle, the constant-voltage phase may

be skipped, but at the cost of usable capacity (only 40% to 70% of usable capacity is achieved) (Lopez). As a result, both charging steps are required to charge the battery completely.

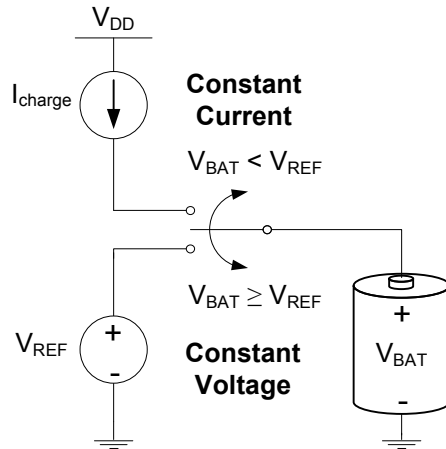

Figure 7. Constant-current/constant-voltage model.

The charging circuit depends on the nature of the input energy that is to be stored in the battery (Texas Instruments). Mainly, the charging current applied to the battery can be either continuous or discontinuous. Continuous charging techniques may utilize linear and switching regulators. A linear regulator linearly controls the conductance of a series pass device via a feedback loop to regulate the output against variations in load current and supply voltage, continuously supplying current. Linear regulators are analogous to resistive voltage dividers in that they can only source voltages below the input supply.

Switching regulators, on the other hand, can boost (step-up) or buck (step-down) the input voltage. In this latter scheme, fully on or off switching devices alternately store and deliver energy to the load via a combination of inductors and capacitors. Viewed from a different perspective, the LC components filter the inherent switching waveforms of the circuit and the duty cycle of these waveforms are in turn normally regulated via a pulse-width modulated (PWM)

controller, or some other switching controller. The supplementary filter and switching controller not only increase the complexity of the charger but also inject high frequency noise to the output. However, the switching nature of these regulators inherently achieves high power efficiency because the switches incur negligible voltage drops, even at high current levels, thereby dissipating little power, when compared to the series pass device of the linear regulator. Although the circuit switches, the output is regulated and can continuously supply a charge current, albeit with a noisy ac ripple.

Discontinuous charging refers to the application of alternating and discrete charge current pulses to the battery. The duty cycle of the pulsating current waveform gradually decreases as full charge conditions are approached. Efficiency is improved because periodically interrupting the charge current allows ions to diffuse and redistribute more evenly, thereby reaching higher capacity levels (Cope). Adding a brief discharge pulse after each charging pulse further accelerates this diffusion process. Table 3 summarizes and compares both types of charging mechanisms. It is noted that each charging scheme depends on a continuous, steady source of energy and is therefore incompatible with intermittent and irregular sources (e.g., electrostatic energy harvesters and other vibration-based generators).

Charger Type	Power Dissipation	Efficiency	Complexity	Noise	Charge Time	Intermittent Source
Continuous	Moderate	Low	Low	Low	Low	No
Discontinuous	Low	Moderate	High	High	High	No

Table 3. Comparison between different charging techniques.

Voltage and current feedback control loops not only protect the battery cell from over-charge and over-discharge but also regulate the charging process. The transition between charging steps, which is controlled by the feedback loops, is vital for an efficient and safe charging

process (Chen). A diode is used to determine which feedback loop dominates and dictates the charging phase. During the constant-current phase, the current feedback loop dominates, regulating the charging current. As the cell voltage nears the end-of-charge voltage (e.g., 4.2 V), the voltage feedback loop begins to acquire control from the current loop, attempting to regulate the cell voltage and therefore trying to decrease the charging current to a lower, more compatible value.

The current feedback control loop can also perform the preconditioning phase and the end-of-charge current and over-current detection. By sensing the current through a series sense resistor (Lima) and adjusting the respective threshold via a comparator, end-of-charge current and over-current conditions are detected and disabling functions asserted, shutting off the charging PMOS transistor. In the same way current is controlled during the constant-current phase, current can also be regulated to a lower value for preconditioning the battery, pre-charging it to approximately 2.7 V, in the case of lithium-ion batteries. The current-control loop is therefore a key component of the charger, performing various phases and safety features.

Voltage feedback control detects the end-of-charge voltage, in this case 4.2 V, and attempts to regulate it during the constant-voltage phase, slowly decreasing the charging current until the end-of-charge current is detected. An error amplifier senses the battery voltage either directly or through a divider circuit, and compares it against a reference voltage. When the cell voltage rises above the reference, the error amplifier shuts off the charging PMOS transistor. Maximum precision of the regulated battery voltage depends on the gain of the feedback loop and the accuracy of the voltage reference. The feedback loop can be either linear or mixed-signal in nature, in other words, switched-sampled. In any event, voltage feedback both protects the bat-

tery from an overcharge and regulates the cell voltage during the constant-voltage charging process.

Additional control safety parameters include time, temperature, and capacity. Implementing a digital timing control scheme detects faults in the battery. If any charging phase takes longer than a specified amount of time, the charger is disabled, avoiding venting of the cell and further damage to the system. Typically, when a battery is fully charged, most of the charge energy generates heat and temperature control assures that the charge process stops during overheating events. This protects the cell from overcharge and charging in harsh environmental conditions, which is damaging to the battery. Monitoring capacity is another safety feature, but the effects of temperature, number of charge cycles, discharge rate, and other factors on capacity must be well understood by the circuit, and this is not a trivial task, to say the least. Many of these supplementary control parameters add redundancy to the system, assuring safe and accurate charge cycles.

III. Energy Harvesting System-in-Package (SiP) Micro-sensor

The proposed system fully integrates into a single plastic package three different ambient energy sources with storage devices, a sensor load, and the circuitry necessary to power and operate the sensor, resulting in a self-contained, self-sustaining system-in-package (SiP) micro-sensor (Figure 8). A thin-film lithium-ion micro-battery stores the energy from vibrations, light, and thermal gradients by way of an efficient charger and delivers it to its sensor load through a voltage regulator circuit.

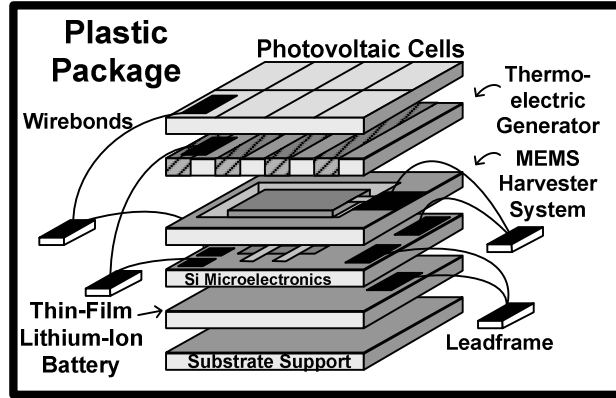

Figure 8. Physical profile view of the proposed system-in-package (SiP) micro-sensor.

The photovoltaic panel is exposed to light and its harvested energy is delivered to the battery via bondwires and the charger circuit. Part of the solar energy is lost as heat, which raises the temperature of the panel and establishes a high temperature on top of the thermopiles. The cold junction of the thermoelectric layer is connected to PCB ground via a thermally conductive path, acting as a heat sink (i.e., thermal ground). The resulting thermal gradient across the thermoelectric generator produces a harvesting voltage (Whitacre), which is used to also charge the battery. The photovoltaic layer serves two functions, as a result, improving its operational efficiency. Additionally, a variable MEMS capacitor (i.e., varactor) harvests energy from vibrations through the electrostatic means. Each harvesting source collaborates and complements each other to provide sufficient energy for the system to operate. In the end, energy harvested from the surrounding environment continually powers the SiP system.

As the capacitance of the MEMS capacitor changes with vibrations, movement, and acceleration are sensed. Motion can therefore be extracted from corresponding changes in capacitance, and energy scavenged is thusly its metric (Harb). As a result, the MEMS capacitor functions as both a motion sensor and an energy harvester, again maximizing the functional efficiency of the system.

Other system components, such as the thin-film lithium-ion micro-battery and supplementary circuitry, occupy separate substrates. The microelectronic circuit layer houses the control circuits of the energy sources, micro-sensor interface electronics, and battery charger, plus all other safety functions. Each substrate is interconnected with one another through the package's leadframe and respective wirebonds, all inside a single plastic package, as conceptually illustrated in Figure 8.

Since all energy sources depend on the conditions of the surrounding environment, extracted energy is intermittent and random in nature, not continuous. Therefore, the proposed system requires a charger that is compatible with such irregular, intermittent energy sources. The charger must therefore be smart enough to accumulate enough energy before transferring it to the battery. A specially designed transitional capacitor is a viable candidate for this purpose. The charger must then combine all three intermittent energy sources and store the collective energy into a single energy storage device, the lithium-ion battery, in this case, as shown in Figure 9. The battery then delivers energy to the sensor load through a regulator circuit.

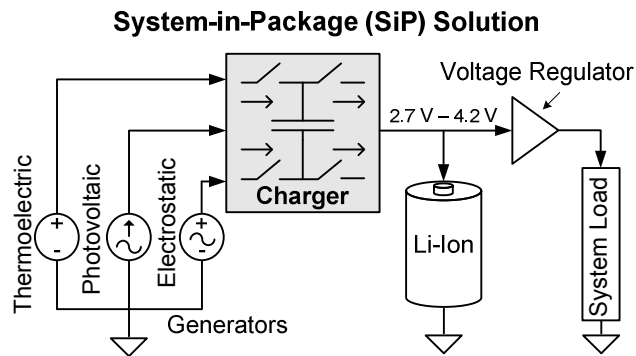

Figure 9. Electrical diagram of the proposed system-in-package (SiP) micro-sensor.

At any given time, the amount of available energy is low, given the low power output of each harvesting source. Consequently, the sensor load must consume minimal power and a time-division multiplex approach is therefore employed. The system functions are divided into different operational modes assigned to consume power in finite bursts, only when needed. Each operational mode, such as data acquisition and processing, transmission, and reception, is allocated asynchronous, low duty-cycle time-segments during which the battery provides the necessary power (Figure 10). Throughout the rest of the cycle, the energy harvesters recover consumed energy and restore it into the battery.

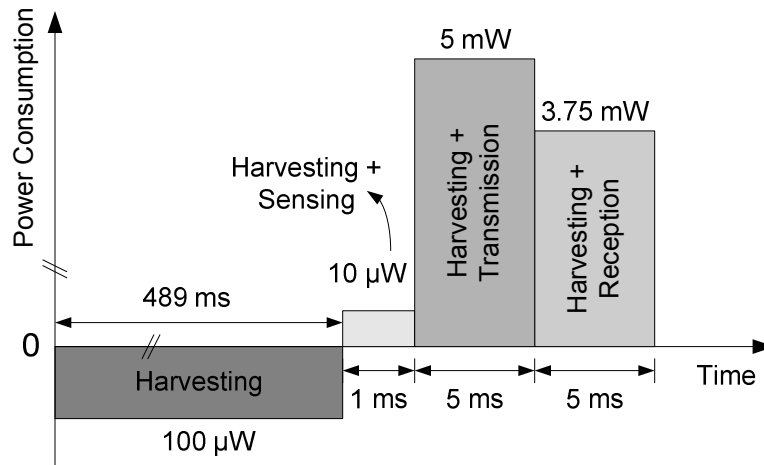

Figure 10. Power profile of the system in a 500 ms cycle.

Typically, sensing functions are supplied about 10 μ W of power for 1 s, while 5 mW for 10 ms are dedicated to transmission and reception functions (Harb). In the proposed system, 5 mW for 5 ms are allocated for transmission and 3.75 mW for another 5 ms for data reception. Motion sensing and energy harvested from vibrations are correlated, which is why battery voltage is used as the metric of motion and sensed after each recovery period. Voltage monitoring,

an already essential component of the charger, serves a dual function. A simple low power and slow analog-to-digital converter (ADC) senses this battery voltage and converts it to a digital word for transmission. This sensing task is estimated to last about 1 ms, less than previously estimated, and consume less than 10 μW . The combined energy output of the harvesters, statistically speaking (Table 1), fully supplies the system just described, allowing it to function continually without external charging cycles or battery swaps.

It is important that all high power tasks are executed when enough energy is stored in the battery. Assuming at least an average harvested power of 100 μW throughout the entire cycle, the system can recover its energy consumption in at least 440 ms, as summarized in Table 4. Harvesting functions are continually performed, and only sensor tasks are given specific time assignments. For more random conditions, the system will enter an asynchronous mode, whereby transmission only occurs if enough energy is stored, in other words, if enough sensing activity is detected, which implies the energy harvested sets both the frequency and duty cycle of the system.

System Requirements				Energy-Harvesting Source Requirements	
	Duration	Power	Energy	Energy Source	Expected Average Power
Transmission	5 ms	5 mW	25 μJ	Electrostatic	50 μW
Reception	5 ms	3.75 mW	18.75 μJ	Photovoltaic	50 μW
Sensing	1 ms	10 μW	10 nJ	Thermoelectric	15 μW
Total: (500 ms cycle)	500 ms	88 μW	~ 44 μJ	Total Average Power Available	115 μW
Harvesting Requirement	> 440 ms	100 μW	44 μJ	Total Available Energy per Cycle (500 ms)	57.5 μJ

Table 4. Estimates of sensor energy consumption and energy-harvesting source requirements.

The system requires maximum efficiency, as it operates under low energy and power conditions. Collaboration between system components becomes necessary to reduce work and energy requirements. The operational efficiency of the photovoltaic panel, voltage monitor, and MEMS variable capacitor exemplify the effective cooperation and functional efficiency desired in the system. With minimal losses, ambient energy suffices to cater to the needs of the system. As a result, the system operates autonomously, without any direct external involvement. What is more, all system components are integrated into a single device, resulting in a long-lasting, self-sufficient system-in-package (SiP) micro-sensor solution.

IV. Conclusion

The proposed self-powered, self-sustaining system-in-package (SiP) solution harnesses, stores, and delivers energy from the surrounding environment to the loading sensor application *in situ*, serving as a virtually endless source of energy. The life of the system is independent of the initially stored energy, since it replenishes its own consumption. Energy from three different harvesting sources is transferred and stored into a micro-battery. The battery not only supplies power to the charger and regulator circuits but also to the sensor load. Light, thermal gradients, and mechanical vibrations source the necessary energy to fully sustain the system. This harvested energy manifests itself in the form of small, intermittent “bursts,” which is why an intermittent boosting charger is required. Since the power harvested is still in the micro-watt scale, the functions of the system are subjected to a time-division multiplex scheme, whereby functions are allocated power and time slices, and only operate when enough energy exists. The system, in the end, constantly restores the energy consumed after every drain event, and does not require replacement of exhausted and/or depleted supplies and/or batteries. This is an attractive feature for

portable electronics and applications with limited accessibility, such as structural-embedded and biomedical implantable devices, just to name a couple.

V. References

- Amirtharajah, R. and Chandrakasan, A.P. (1998). "Self-powered signal processing using vibration-based power generation". *IEEE Journal of Solid-State Circuits*, 33: 687-695.
- Bates, J.B., Dudney, N.J., Neudecker, B., Ueda, A., and Evans, C.D. (2000). "Thin-film lithium and lithium-ion batteries". *Solid State Ionics*, 135: 33-45.
- Bennett, D.M., Selfridge, R.H., Harb, J.N., and Comer, D.T. (2004). "A control circuit for a micro-sensor hybrid power supply". *IEEE Transactions on Industrial Electronics*, 51: 74-80.
- Castano, E., Revuelto, E., Martin, M.C., Garcia-Alonso, A., and Gracia, F.J. (1997). "Metallic thin-film thermocouple for thermoelectric microgenerator". *Sensors and Actuators A*, 60: 65-67.
- Chen, M. and Rincon-Mora, G.A. (2005). "Accurate and compact Li-ion battery charger designed for maximum capacity and cycle life". *Electronics Letters*, Pending.
- Cope, R.C. and Podrazhansky, Y. (1999). "The art of battery charging". *14th Annual Battery Conference on Applications and Advances*, 233-235.
- DiSalvo, F.J. (1999). "Thermoelectric cooling and power generation". *Science*, 285: 703-706.
- El-Hami, M., Glynne-Jones, P., White, N.M., Hill, M., Beeby, S., James, E., Brown, A.D., and Ross, J.N. (2001). "Design and fabrication of a new vibration-based electromechanical power generator". *Sensors and Actuators A*, 92: 335-342.
- Fleurial, J.P., Snyder, G.J., Herman, J.A., Giauque, P.H., Phillips, W.M., Ryan, M.A., Shakkottai, P., Kolawa, E.A., and Nicolet, M.A. (1999). "Thick-film thermoelectric microdevices". *18th International Conference on Thermoelectrics*, 294-300.

- Harb, J.N., LaFollette, R.M., Selfridge, R.H., and Howell, L.L. (2002). "Microbatteries for self-sustained hybrid micropower supplies". *Journal of Power Sources*, 104: 46-51.
- Kasap, S.O. (2001). *Optoelectronics and Photonics: Principles and Practices*. Prentice-Hall.
- Kiely, J.J., Morgan, D.V., Rowe, D.M., and Humphrey, J.M. (1991). "Low cost miniature thermoelectric generator". *Electronic Letters*, 27: 2332-2334.
- Kulah, H. and Najafi, K. (2004). "An electromagnetic micro power generator for low-frequency environmental vibrations". *17th IEEE International Conference on Micro Electro Mechanical Systems (MEMS)*, 237-240.
- Lam, Y.H., Ki, W.H., Tsui, C.Y., and Mok, P.K. (2003). "Single inductor dual-input dual-output switching converter for integrated battery charging and power regulation". *Proceedings of the 2003 IEEE International Symposium on Circuits and Systems*, 3: 447-450.
- Lima, F., Ramalho, J.N., Tavares, D., Duarte, J., Albuquerque, C., Marques, T., Geraldés, A., Casimiro, A.P., Renkema, G., Been, J., and Groeneveld, W. (2003). "A novel universal battery charger for NiCd, NiMH, Li-ion, and Li-polymer". *29th European Solid-State Circuits Conference*, 209-212.
- Linden, B. and Reddy, T.B., (2002). *Handbook of Batteries*. New York: McGraw-Hill.
- Lopez, J., Gonzalez, M., Viera, J.C., and Blanco, C. (2004). "Fast-charge in lithium-ion batteries for portable applications". *26th Annual International Telecommunications Energy Conference*, 19-24.
- Meninger, S., Mur-Miranda, J.O., Amirtharajah, R., Chandrakasan, A.P., and Lang, J.H. (2001). "Vibration-to-electric energy conversion". *IEEE Transactions on Very Large Scale Integration (VLSI) Systems*, 9: 64-76.

- Ottman, G.K., Hofmann, H.F., Bhatt, A.C., and Lesieutre, G.A. (2002). "Adaptive piezoelectric energy harvesting circuit for wireless remote power supply". *IEEE Transactions on Power Electronics*, 17: 669-676.
- Ottman, G.K., Hofmann, H.F., and Lesieutre, G.A. (2003). "Optimized piezoelectric energy harvesting circuit using step-down converter in discontinuous conduction mode". *IEEE Transactions on Power Electronics*, 18: 696-703.
- Raffaella, R.P., Underwood, J., Scheiman, D., Cowen, J., Jenkins, P., Hepp, A.F., Harris, J., and Wilt, D.M. (2000). "Integrated solar power systems". *28th IEEE Photovoltaic Specialists Conference*, 1370-1373.
- Roundy, S., Wright, P.K., and Pister, K.S. (2002). "Microelectrostatic vibration-to-electricity converters". *Proceedings of the ASME International Mechanical Engineering Congress and Expo*.
- Roundy, S., Wright, P.K., and Rabaey, J. (2003). "A study of low level vibrations as a power source for wireless sensor nodes". *Computer Communications*, 26: 1131-1144.
- Roundy, S., Steingart, D., Frechette, L., Wright, P., and Rabaey, J. (2004a). "Power sources for wireless sensor networks". *Wireless Sensor Networks*, 1-17.
- Roundy, S. and Wright, P.K. (2004b). "A piezoelectric vibration based generator for wireless electronics". *Smart Materials and Structures*, 13: 1131-1142.
- Rowe, D.M. (1999). "Thermoelectrics, an environmentally friendly source of electrical power". *Renewable Energy*, 16: 1251-1256.
- Russ, R. (2002). "Battery power trade-offs: lower voltage or higher capacity?" *EE Times*, July 29, 2002.

- Scherrer, H., Vikhor, L., Lenoir, B., Dauscher, A., and Poinas, P. (2003). "Solar thermoelectric generator based on skutterudites". *Journal of Power Sources*, 115: 141-148.
- Sodano, H.A., Inman, D.J., and Park, G. (2004a). "A review of power harvesting from vibration using piezoelectric materials". *The Shock and Vibration Digest*, 36: 197-205.
- Sodano, H.A., Park, G., Inman, D.J. (2004b). "Estimation of electric charge output for piezoelectric energy harvesting". *Strain*, 40: 49-58.
- Stark, B.H., Mitcheson, P.D., Miao, P., Green, T.C., Yeatman, E.M., and Holmes, A.S. (2004). "Power processing issues for micro-power electrostatic generators". *35th Annual IEEE Power Specialists Conference*, 4156-4162.
- Stordeur, M. and Stark, I. (1997). "Low power thermoelectric generator – self-sufficient energy supply for micro systems". *16th International Conference on Thermoelectrics*, 575-577.
- Sun, W., Kherani, N.P., Hirschman, K.D., Gadeken, L.L., and Fauchet, P.M. (2005). "A three-dimensional porous silicon p-n diode for betavoltaics and photovoltaics". *Advanced Materials*, 17: 1230-1233.
- Texas Instruments. (2004). *Portable Power Design Seminar*.
- Wang, W., Jla, F., and Zhang, J. (2003). "A new type of micro-thermoelectric power generator fabricated by nanowire array thermoelectric material". *22nd International Conference on Thermoelectrics*, 682-684.
- Warneke, B.A., Scott, M.D., Leibowitz, B.S., Zhou, L., Bellew, C.L., Chediak, J.A., Kahn, J.M., Boser, B.E., and Pister, K.S. (2002). "An autonomous 16 mm³ solar-powered node for distributed wireless sensor networks". *Proceedings of IEEE Sensors*, 2: 1510-1515.
- Whitacre, J., Fleurial, J.P., Mojarradi, M., Johnson, T., Myung, N., Ryan, A., and Neigh, S. (2002). "An integrated power generation and storage system: the power tile". In E.J.

Brandon, A. Ryan, J. Harb, and R. Ulrich, Eds., *Micropower and Microdevices: Proceedings of the International Symposium*, pp. 203-214.

Williams, C.B. and Yates, R.B. (1996). "Analysis of a microelectric generator for microsystems". *Sensors and Actuators A*, 52: 8-11.

Williams, C.B., Shearwood, Harradine, M.A., Mellow, P.H., Birsch, T.S., and Yates, R.B. (2001). "Development of an electromagnetic micro-generator". *IEE Proceedings – Circuits, Devices, and Systems*, 148: 337-342.