

A Novel Predictive Inductor Multiplier for Integrated Circuit DC-DC Converters in Portable Applications

Lucas Andrew Milner, *Student Member, IEEE*
Georgia Tech Analog and Power IC Design Lab
777 Atlantic Drive
Atlanta, GA 30332-0250
lamilner@ece.gatech.edu

Gabriel A. Rincón-Mora, *Senior Member, IEEE*
Georgia Tech Analog and Power IC Design Lab
777 Atlantic Drive
Atlanta, GA 30332-0250
rincon-mora@ece.gatech.edu

ABSTRACT

While the large passive elements of power converters are in the way of converging walls of shrinking cell phones and cameras, the new capabilities these devices flaunt are creating additional burdens and making it difficult to meet specifications without even bigger elements. Active circuits that enhance the effects of passive elements will allow power converters to handle larger loads and get smaller at the same time. This paper presents a predictive inductor multiplier circuit that amplifies the effective inductance in a Buck converter. The output ripple of the simulated converter is so small that the converter appears to have an inductance thirty-eight times the value actually used. Compensating for small inductors introduces new power losses, but it is discovered that linear regulators and faster switching converters can be even less efficient.

Categories and Subject Descriptors:

B.7.1 [Integrated Circuits]: Types and Design Styles

General Terms:

Performance, Design

Keywords:

Power Management, Integrated Inductors, Inductor Multipliers, Active Ripple Filters

1. INTRODUCTION

Portable electronics are becoming more compact and more versatile to satisfy consumer demand for convenience and style and to realize industrial dreams of a world filled with sensors. While cell phones have swallowed digital cameras, game consoles, and media players without gaining any weight, similarly thin, light electronic organizers now boast of their talents for wireless web browsing and global positioning. Further integration could feature all of this functionality in a single chip and new intelligent sensors embedded in everything from clothing to coffee mugs [1], [2]. However, these dreams imply conflicting requirements for power management circuits, which need large passive elements to reliably support all of these new features. Switching regulators use inductors and capacitors to transform and filter

Permission to make digital or hard copies of all or part of this work for personal or classroom use is granted without fee provided that copies are not made or distributed for profit or commercial advantage and that copies bear this notice and the full citation on the first page. To copy otherwise, or republish, to post on servers or to redistribute to lists, requires prior specific permission and/or a fee.

ISLPED '05, August 8–10, 2005, San Diego, California, USA.
Copyright 2005 ACM 1-59593-137-6/05/0008...\$5.00.

supply voltages, and these elements are already made as small as possible to save space. The sizes of these components are inversely proportional to the unwanted ripple on the regulated output, and therefore, as shrinking portable electronics draw more power to perform more numerous and demanding tasks, regulators will actually need larger passive elements to keep pace. The use of smaller components can translate into an unsteady and useless supply for subcircuits in the system.

Linear regulators avoid this conflict because they do not require large inductors and capacitors. In a linear regulator, a transistor is connected between the unregulated input and the regulated output supply. The circuit is effectively a variable voltage divider, and it yields a steady output voltage regardless of the current demanded. However, the output current is always the same as the input current, and this means that the efficiency of a linear regulator can never be higher than the ratio of output to input voltage. This is a major limitation in very common situations like when a Lithium ion battery in the three to four volt range provides power for one to two volt digital circuits.

Switching regulators are very popular, because they can efficiently convert supply voltages regardless of the conversion ratio. One type is a switched capacitor converter, also called a charge pump. In these topologies, one or more capacitors are connected to the source to charge for a period of time. They are then connected to the load where they deliver the output current and sustain the output voltage. Depending on whether the capacitors are connected to the source and load in series or in parallel, these topologies can produce output voltages that are higher or lower than the input. These circuits are popular with designers because they do not use inductors, which are expensive. However, the conversion ratio is fixed by the topology, which makes them less versatile than the other type of switching regulators [3]-[6].

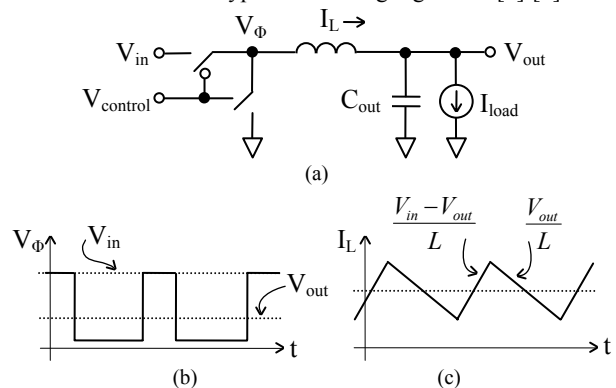

Figure 1. A Buck converter (a) is shown with pulse voltage (b) and inductor current waveforms (c).

Switched converters that use inductors are the most versatile of power management circuits, because the possible conversion ratios are unlimited. Figure 1 shows the schematic of a Buck converter, which provides a low output voltage from a higher input. In this circuit, the two switches are opened and closed in a complimentary fashion, so that the voltage at the intermediate node, V_ϕ , is a square pulse with a specific duty cycle. The desired output of the circuit is the average of this pulse, equal to the product of the input voltage and the duty cycle. The inductor and capacitor form a second-order filter to reduce the higher frequency components and leave the output voltage with little or no ripple.

With few exceptions [7], these passive elements reside off the chip because of their physical dimensions. The effects of smaller inductors and capacitors can be compensated for by switching faster, which moves the frequency harmonics in the V_ϕ waveform higher in the spectrum where the attenuating action of the inductor and capacitor combination is greater. This strategy consumes power in the form of greater switching losses and it therefore lowers efficiency. An alternative is to develop active circuits that multiply the effect of the passive elements. Inductor multipliers, in particular, can compliment recent work on integrated inductor fabrication technologies [8]-[10]. The combination of inductor multipliers with these larger inductors can allow smaller, system-on-chip converters with equal or better precision than discrete versions. However, the value of such converters to product designers will also be determined by the losses incurred by the multiplier. A Buck converter with an inductor multiplier must be more efficient than a linear regulator to be useful, and similarly, the cost of adding the multiplier must be less than that of switching faster. Section II will discuss different approaches to inductor multipliers, Section III will present a new circuit, and Section IV will evaluate its performance.

2. INDUCTOR MULTIPLIERS

Active devices could substitute for the inductor altogether. In particular, transconductance-capacitor (Gm-C) filters can reproduce the frequency response of an inductor [11] [12], and they previously have drawn attention in this application [13]. However, this technique requires that an active element pass the dc current as one does in a linear regulator, and a switching converter that used it would be even less efficient than one. Consequently, it makes more sense to enhance the inductor than to replace it.

The concept of inductor multiplication originates in the fundamental relationship between current and voltage for an inductor,

$$v = L \cdot \frac{di}{dt}. \quad (1)$$

Dividing the voltage across the inductor by a factor has the same effect on the current ripple as multiplying the inductance by that factor. This has been called voltage mode inductor multiplication [13]. In contrast, the current mode approach keeps the voltage constant. Then if part of the ripple is redirected from the output of the inductor, the effect on other elements is the same as using a bigger inductor. The voltage mode approach is problematic for power converters because it requires the addition of lossy elements in series with the inductor [14] or some sort of dc-dc conversion for itself, but the current mode approach is promising especially in the context of a Buck converter, because in that topology, redirecting leftover ripple amounts to active ripple filtering. Others have viewed the problem in this way and had success [15]-[17].

The techniques they have proposed can be divided several ways, but the most important distinction is between those that sense the ripple and those that predict it, as shown in Figure 2 and Table 1. The former can sense the current ripple through the inductor or the voltage ripple at the output node, though in [15] and [16], strategies for sensing the inductor current directly proved to be either very difficult or unreliable. In contrast, applications of the voltage sensing strategy (Figure 2a) have effectively multiplied the inductance by 130 when the output ripple is already small [15] and by 10 under harder conditions [13].

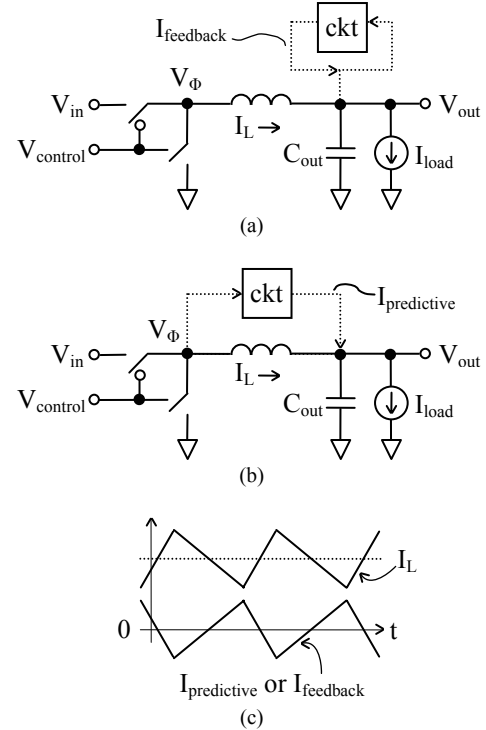

Figure 2. The feedback (a) and predictive (b) approaches both generate complimentary ripple currents (c).

The predictive approach (Figure 2b) exploits the topology of the Buck converter, and the familiar and simple voltage and current waveforms produced within it [17]. It relies on the fact that while either switch in the Buck converter is closed, the voltage impressed across the inductor is constant assuming a negligible ripple at the output. If the inductance is known, then the current through it rises or falls at a predictable rate, and a complimentary current ripple (Figure 2c) can be generated and injected at the output so that the voltage there is steady. In [17], the inductor gain varies from six to ten for a range of load conditions. Table 1 compares the solutions in their important respects.

Since these are all current-mode approaches, they will all consume the same power to cancel the inductor ripple current. Therefore, the efficiency of a converter should be about the same regardless of which multiplier is used. The predictive approach is more stable, since it uses a feedforward path, but it is probably less accurate than the voltage sensing approach for the same reason. Since the difference in stability is inherent, but the difference in accuracy may not be, the predictive approach is the best with which to start.

Table 1. Comparison of Active Multipliers

	Sensing (Feedback)		Predicting (Feedforward) [17]
	Current [15][16]	Voltage [13][15]	
Area	Poor	Excellent	Excellent
Stability	Good	Good	Excellent
Efficiency	Good	Good	Good
Accuracy	Poor	Excellent	Good

3. PROPOSED CIRCUIT

The current through the inductor in a Buck converter is a triangle wave. It ramps up at a rate proportional to the difference between the input and output voltages, and it ramps down at a rate proportional to just the output voltage. The easiest way to generate such a wave is to inject a square pulse into a capacitor, as shown in Figure 3. One level of the pulse should be proportional to the difference between the input and output voltages, and the other proportional to just the output voltage.

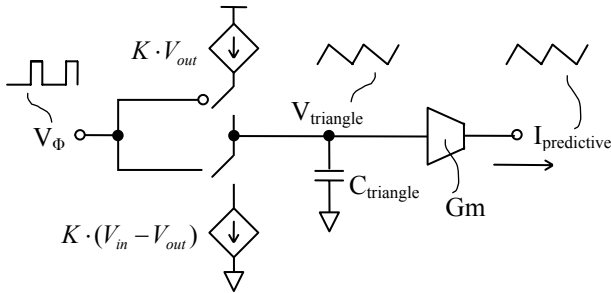

Figure 3. Concept for building a triangular wave.

This is a more precise way of building a complimentary ripple from the information available in the converter than the classic integrator used in [17]. The current sources can be implemented by forcing the necessary voltages across resistors and mirroring the resulting currents as shown in Figure 4. When the current through the inductor is decreasing (V_ϕ is low), an opamp imposes a reference equal to the output voltage across a resistor. The resistor current is mirrored and sourced to the capacitor, $C_{triangle}$. A similar thing happens during the other half of the cycle, when a constant current proportional to the difference of V_{in} and V_{out} flows out of $C_{triangle}$. This process will create a triangular voltage waveform across $C_{triangle}$ as long as that waveform does not clip at V_{in} or ground. For this reason, $V_{triangle}$ is biased at an intermediate voltage, V_{bias} .

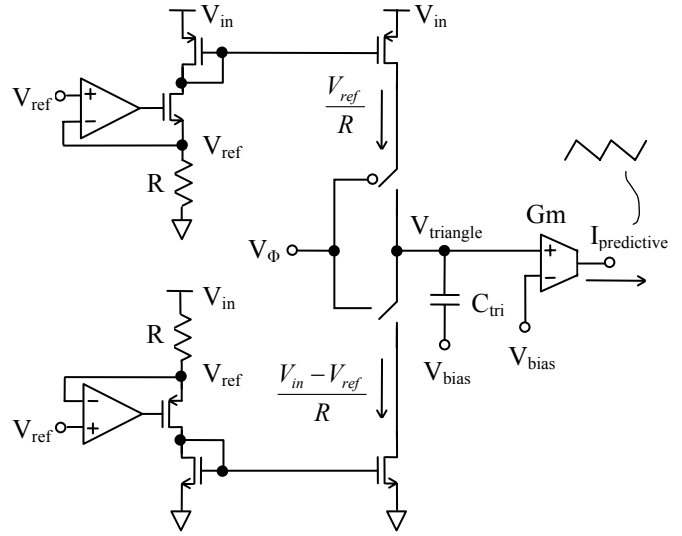

Figure 4. Implementation of controlled current sources.

Any error in the currents that alternately flow in and out of $C_{triangle}$ will cause the dc level of the voltage across it, $V_{triangle}$ to drift towards V_{in} or ground. Adding a large resistor in parallel with $C_{triangle}$ will prevent that but it will also allow a dc offset to reach the transconductor. If this happens, the transconductor will conduct a dc current as part of the load current that the inductor would normally carry alone, and the efficiency of the converter will decrease.

Consequently, it is important to limit any offsets in the circuit leading to the transconductor. One source of mismatch is the pair of opamps that may have different input offset voltages. If one opamp is used to alternately control both mirrors this source of error is neutralized. Figure 6 shows how the mirrors can share the opamp with the aide of four switches.

The mirrors themselves may have dc offsets, and so a high-pass filter is added to the combination of $C_{triangle}$ and a large resistor, as shown in Figure 6. The complete filter must filter dc offsets and integrate the square current pulse as a single capacitor would and as shown in Figure 5.

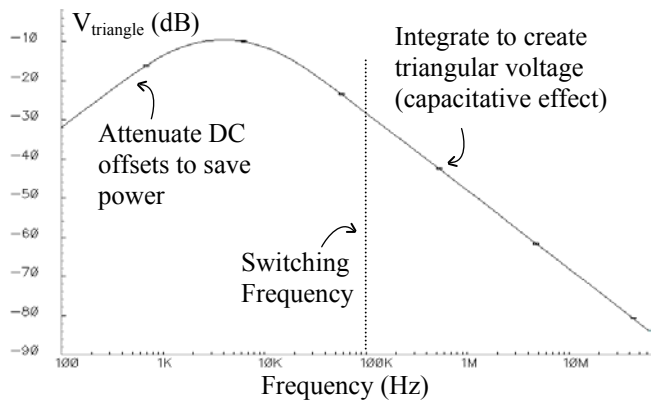

Figure 5. Filter frequency response.

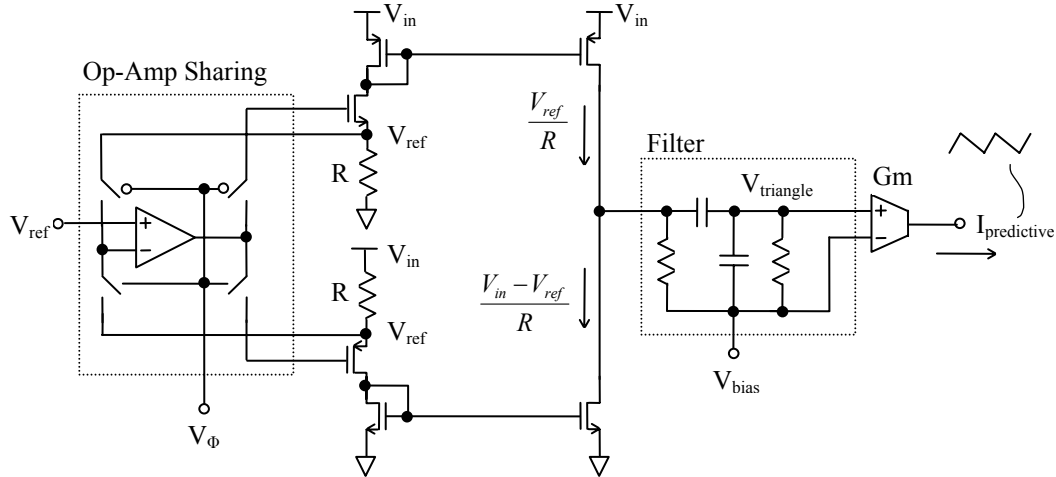

Figure 6. Implementation of Op-Amp sharing and additional filtering.

4. SIMULATION RESULTS

An open-loop Buck converter with a $1\mu\text{H}$ inductor and a $10\mu\text{F}$ capacitor was simulated at 100kHz with a fifty percent duty cycle and a 1A load current. Without the inductor multiplier, the output voltage had a very large ripple as shown in Figure 7. That ripple is thirty-eight times smaller with the inductor multiplier.

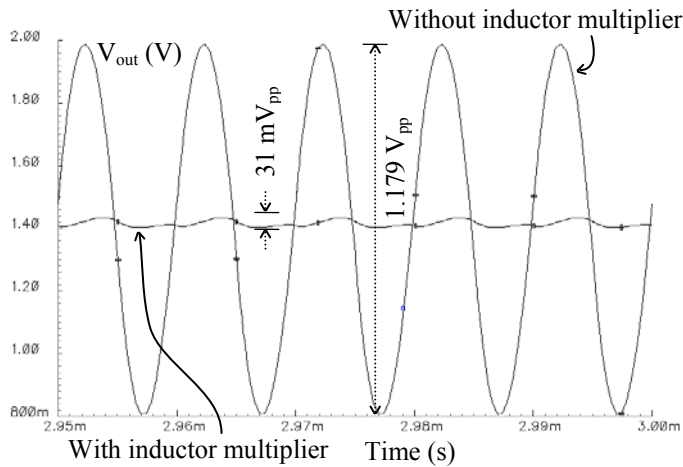

Figure 7. Output voltage with and without the multiplier.

The attenuated ripple has new frequency components, because the synthesized ripple does not vary from an ideal triangle wave in the same way that the inductor ripple does. This imperfect cancellation is shown in Figure 8. Interestingly, the inductor current ripple is decreased by a factor less than twenty, which is slightly more than half the factor by which the output voltage ripple of the converter has been decreased. The capacitor makes up the difference because it filters a higher frequency current ripple ($I_L + I_{\text{predictive}}$) than normal (I_L).

Other than the multiplication factor, the most important metric for the inductor multiplier is the new efficiency of the Buck converter. However, this is dependent on the size of the inductor current ripple and the efficiency of the original converter. This makes comparing inductor multipliers to linear regulators and faster converters a project by itself. In an earlier study involv-

ing one simulated converter, decreasing the inductance and adding the inductor multiplier reduced the efficiency of the original converter from 86% to 74% [13]. A linear regulator designed for the same conversion ratio would have been 68% efficient, while a converter switching fast enough to produce the same low ripple would have been 78% efficient.

However, using the inductor multiplier instead of a higher switching frequency can actually save power. It can be shown that when switching losses are already high, increasing the switching frequency to reduce the ripple consumes more power than generating a complimentary ripple.

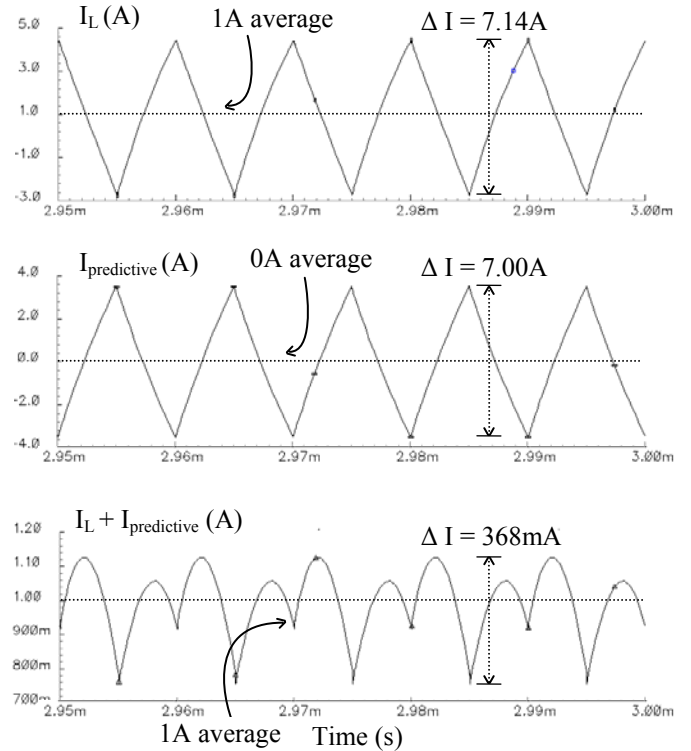

Figure 8. Inductor current, predictive current, and sum.

To begin, switching losses are proportional to frequency as shown in Eq. 2,

$$P_{switching} = V_{in} \cdot I_{load} \cdot t_x \cdot f. \quad (2)$$

where t_x is the combined rise and fall time of the switches in the Buck converter. The losses introduced by the multiplier are determined by the inductor current ripple and the supply voltage of the transconductor (Gm), as shown in Figure 9.

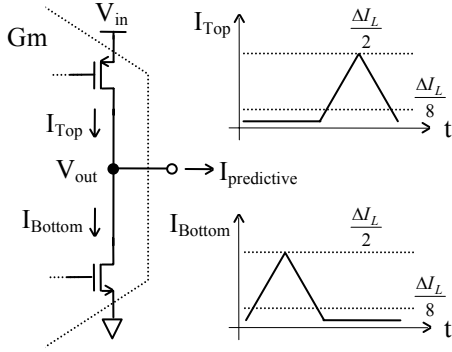

Figure 9. Transconductor (Gm) stage and current waveforms.

Each transistor in the output stage will have to conduct half of the synthetic complimentary ripple each period, and the average current through them will be equal. The voltage across the top transistor is always the difference in the input and output voltages, while the voltage across the bottom is just the output voltage. Summing the constant voltages across the transistors and multiplying by the average current through them gives the total power lost in these elements,

$$P_{multiplier} = V_{in} \cdot \frac{\Delta I_L}{8}. \quad (3)$$

Table 2. Example Of Converter Losses

	Faster Switching	Inductor Multiplier	Big Discrete Inductor
f	5.5MHz	1MHz	1MHz
ΔI_L	136mA	750mA	25mA
DC	224mW	224mW	224mW
RMS	1.02μW	3.09mW	3.44μW
SW	660mW	120mW	120mW
LMX	0mW	280mW	0mW
Total	884W	628mW	344mW
Efficiency	77.2%	82.7%	89.7%

An integrated converter might have the following specifications: $V_{in}=3V$, $V_{out}=1.5V$, $L=1\mu H$, $C=1\mu F$, $I_{out}=2A$, $R_{HS}=75m\Omega$, $R_{LS}=10\Omega$, $R_{ESRL}=R_{ESRC}=10m\Omega$, and $t_x=20ns$. In this case, if the proposed circuit multiplies the effective inductance by a factor of thirty, then a similar converter without the multiplier would have to switch five and a half times faster to achieve the same accuracy. As shown in Table 2, the inductor multiplier introduces 280mW of unique losses (LMX), but switching losses (SW) in the other converter start at 120mW and multiply by 5.5. The circuit with the inductor multiplier is more than 5% more efficient. A consequence of the above equations is that larger on-chip inductors, higher switching frequencies, and higher loads all increase the advantage of inductor multipliers in relative efficiency.

The inductance used in the example is larger than can be produced on chip, but only to demonstrate clearly the advantage of inductor multiplication. Even though integration onto the IC is the ultimate purpose, this technique would also save board area by reducing the necessary inductance to that size. Also, the feasibility and cost of applying the technique to every inductor on chip is not here considered, because one main power inductor for the entire chip is envisioned, and the inductor current waveforms in other applications may not be as simple to process.

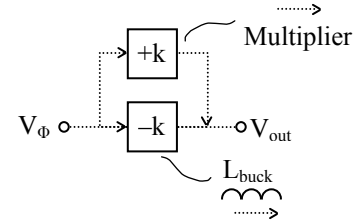

Figure 11. Cancellation of forward paths.

A disadvantage of using the predictive inductor multiplier is degradation of the transient response. As shown in Figure 11, the added path from V_ϕ to V_{out} , through the inductor multiplier cancels the original path through the real inductor, so that no trace of the ac component of V_ϕ appears at V_{out} . This is, after all, the point of the inductor and the inductor multiplier. However, if the two paths cancel perfectly, the converter cannot respond to load transients as the control loop from V_ϕ to V_{out} and back to V_ϕ is effectively open. Essentially, as the effective inductance increases towards infinity so does the settling time of the converter. The effect would be no different if a large inductor were used. It is the same tradeoff that designers already face. However, the possibility remains that the inductor multiplier can be switched out of the circuit, leaving only a small inductor and a fast converter for large transients. This may eliminate the tradeoff altogether.

5. CONCLUSIONS

There are clearly cases in which inductor multipliers are the most efficient way to integrate dc-dc converters on chip. This implementation of the predictive technique multiplies the inductor almost forty times. Defining the set of cases in which its use is appropriate is difficult, however. Generally, when the initial ripple is already low, an inductor multiplier will further attenuate it more efficiently than increasing the switching frequency can. Progress in on-chip and on-package inductor fabrication technologies consequently favors inductor multipliers. Because of it, the situations in which dc-dc converters are preferable to linear regulators will become more numerous, and inductor multipliers will help to

make room for even more functionality in longer-lasting and more compact portable electronics.

6. REFERENCES

- [1] H. Goldstein, "Mike Villas's World," *IEEE Spectrum*, vol. 41, no. 7, pp. 45-48, July 2004.
- [2] P.E. Ross, "Managing Care Through the Air, Remote Health Monitoring," *IEEE Spectrum*, vol. 41, no. 12, pp. 26-31, Dec 2004.
- [3] E. Bayer and H. Schmeller, "A High Efficiency Single-Cell Cascaded Charge Pump Technology—The Competitive Alternative to Inductive Boost Converters," in *32nd Annual Power Electronics Specialists Conference*, vol. 1, pp. 290-295, 2001.
- [4] H.S. Chung, "Design and Analysis of a Switched-Capacitor-Based Step-Up DC-DC Converter With Continuous Input Current," *IEEE Trans. on Circuits and Systems I*, vol. 46, no. 6, pp. 722-730, June 1999.
- [5] R. Chebli and M. Sawan, "A CMOS High-Voltage DC-DC Up Converter Dedicated For Ultrasonic Applications," *4th IEEE International Workshop on System-on-Chip for Real-Time Applications, 2004*, pp. 119-22.
- [6] T.R. Ying, W.H. Ki, and M. Chan, "Area-Efficient CMOS Charge Pumps for LCD Drivers," *IEEE Journal of Solid-State Circuits*, vol. 38, no. 10, pp. 1721-1725, Oct 2003.
- [7] S. Orr, "Integrated Magnetics Shrinks DC-DC Converter," *EE Times*, May 25, 2004.
- [8] Z. Hayashi, Y. Katayama, M. Edo, and H. Nishio, "High-Efficiency DC-DC Converter Chip Size Module With Integrated Soft Ferrite," *IEEE Transactions on Magnetics*, vol. 39, no. 5, Sep 2003.
- [9] T. Sato, M. Hasegawa, T. Mizoguchi, and M. Sahashi, "Planar Inductors for Very Small DC-DC Converters," *Telecommunications Energy Conference 1991*. pp. 709-713.
- [10] J. Park and M.G. Allen, "Ultralow-Profile Micromachined Power Inductors with Highly Laminated Ni/Fe Cores: Application to Low-Megahertz DC-DC Converters," *IEEE Trans. on Magnetics*, vol. 35, no. 5, pp. 3184-3186, Sep 2003.
- [11] R.H.S. Riordan, "Simulated Inductors Using Differential Amplifiers," *Electronics Letters*, vol. 3, no. 2, pp. 50-51, Feb 1967.
- [12] T. Deliyannis, Y. Sun, and J.K. Fidler, *Continuous-Time Active Filter Design*, Boca Rotan, Florida: CRC Press LLC, 1999, ch. 3.
- [13] A. Makharia and G.A. Rincón-Mora, "Integrating Power Inductors onto the IC-SOC Implementation of Inductor Multipliers for DC-DC Converters," in *Proc. 28th Annual Conference of the IEEE Industrial Electronics Society 2002*, vol. 1, pp. 556-561.
- [14] Y.H. Oh and S.G. Lee, "An Inductance Enhancement Technique and Its Application to a Shunt-Peaked 2.5 Gb/s Transimpedance Amplifier Design," *IEEE Trans. On Circuits and Systems II*, vol. 51, no. 11, pp. 624-628, Nov. 2004.
- [15] D.C. Hamill and O.T. Toh, "Analysis and Design of an Active Ripple Filter for DC-DC Applications," in *Proc. Of Applied Power Electronics Conference and Exposition 1995*, vol. 10, pp. 267-273.
- [16] L.E. LaWhite and M.F. Schlect, "Active Filters for 1-MHz Power Circuits with Strict Input/Output Ripple Requirements," *IEEE Transactions on Power Electronics*, vol. PE-2, no. 4, Oct 1987.
- [17] P. Midya and P.T. Krein, "Feed-forward Active Filter for Output Ripple Cancellation," *International Journal of Electronics*, vol. 77, no. 5, pp. 805-818, 1994.