

Design Methodology of a Hybrid Micro-Scale Fuel Cell-Thin-Film Lithium Ion Source

Min Chen, Justin P. Vogt, *Student Member, IEEE*, and Gabriel A. Rincón-Mora, *Senior Member, IEEE*
Georgia Tech Analog, Power, and Energy IC Research Lab
Email: min.chen.us@gmail.com, jvogt@ece.gatech.edu, rincon-mora@ece.gatech.edu

Abstract—Emerging ad-hoc wireless sensor nodes and other micro-scale applications demand long operational lives, small form factors, and total integration, which are next to impossible to fully achieve with conventional battery technologies. Efficient, power-moded, fully integrated systems inherently demand high peak-to-average power ratios (PAPRs), as in wireless sensor applications where telemetry is a power-consuming function with low duty-cycle operation. Lithium ion batteries (Li-Ion), while conforming to micro-scale dimensions and supplying moderate power densities, cannot store enough energy to sustain extended lifetimes, which is where fuel cells (FCs) excel. Although various control strategies for energy flow between batteries and FCs have been proposed in the past, none of them superimpose the severe constraints of a micro-scale system on the design, where volume, energy, and power are scarce and the performance of the MEMS FCs degrade with time. This paper presents a hybrid micro-scale MEMS FC-thin-film Li-Ion source and proposes a design methodology for the same wherein volume, energy, and power are optimized for peak-power and extended-lifetime performance. The FC is ultimately used to both charge and supply the load asynchronously, depending on the state of the load, while the Li Ion mostly functions as a power cache. System simulations of a multi-sensor wireless system load show and validate how peak-power, average-power, duty-cycle, and frequency performance are achieved and how they relate to lifetime.

I. INTRODUCTION

MOORE'S LAW [1] has become the integration metric by which the semiconductor industry is gauged, but applying it to battery technologies proves disappointing. Wireless sensors and other micro-scale systems for biomedical, military, space, and consumer use demand small form factor, extended battery life, stand-alone operation, and full integration. Unfortunately, conventional lithium ion (Li-Ion), nickel cadmium (NiCd), nickel-metal hydride (NiMH), and other batteries, when conforming to micro-scale dimensions, cannot supply the energy required to sustain a practical electronic system. The end result is a tiny chip powered from a bulky off-chip battery.

One plausible solution is to continually scavenge thermal, solar, and/or kinetic energy from the environment [2] and use it to supply a system. Its effectiveness, however, is dependent on the application and its surroundings. Thermal harvesting, for instance, requires large thermal gradients, which are not normally present in micro-scale applications, and solar and vibrational energy are subject to the sun (other light sources provide limited power) and motion. Although scavenging energy is appealing, its intermittent power levels, asynchronous nature, and cumbersome harvesting requirements are difficult to overcome, which is why exploring how to manage environmentally independent hybrid sourcing technologies to concurrently supply high power and high energy is important.

Researchers have proposed various control strategies to manage and control energy flow between batteries and macro-scale FCs with constant, time-independent fuel flow, fuel concentration, and I-V

performance [3-4]. Many of these assumptions, like constant fuel flow, fuel concentration, and I-V performance of FCs, however, lose invalidity in micro-scale applications. A FC under severe volume constraints behaves like a battery in that it can only supply a finite amount of energy (small fuel tank must be considered), and its power output, since fuel concentration is diluted with time, degrades with time. A micro-scale design methodology must therefore account for a severely volume-constrained system with sub-standard FC performance and project the optimal volume combination of a hybrid *in situ* FC-Li Ion source for maximum operational life under a given load profile whose working conditions deviate substantially from the constraints considered in prior work. Such a design methodology is proposed, presented, and discussed in this paper. Micro-systems are therefore first explored in Section II. Section III proposes a design methodology for the hybrid micro-scale energy source that is capable of supplying high power, high energy, and high peak-to-average power ratios (PAPRs) and Section IV validates and studies it via system-level simulations. Section V draws relevant conclusions.

II. MICRO-SYSTEM

A complete electronic system (Fig. 1) is typically comprised of energy sources, power-conditioning circuits, and functional system loads (e.g., sensors, telemetry, etc.). Whereas the energy sources and loads are dependent on technology and application, the conditioning electronics, under the guise of a power scheme, manage how power is stored, delivered, and conditioned to achieve high system efficiency (extended lifetime). As a result, an optimally designed system selects and configures its electronics (e.g., switching DC-DC converters, chargers, charge pumps, etc.) to efficiently derive power from the best energy source (out of available technologies) when presented with a particular load power level (or mode), thereby configuring the system to always supply power with the highest possible efficiency and therefore achieve the longest lifetime possible.

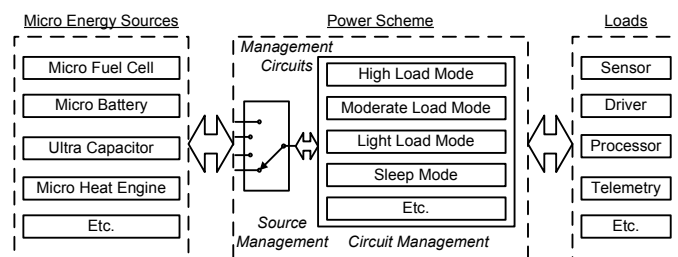

Fig. 1. Micro-scale electronic system diagram.

A. Direct-Methanol FC (DMFC): Direct-methanol FCs (DMFCs) built with micro-electro-mechanical systems (MEMS) technologies provide the micro-scale dimensions and high energy density characteristics desired in micro-scale solutions [5-7]. A MEMS DMFC can be fabricated on a silicon wafer substrate (Fig. 2(a)), and although its power density levels are limited and its response time is on the order of seconds (Table I and Fig. 3), its potential energy density levels are high [8-9]. FCs are therefore best suited for low and constant power load levels (not for fast changing or higher power applications).

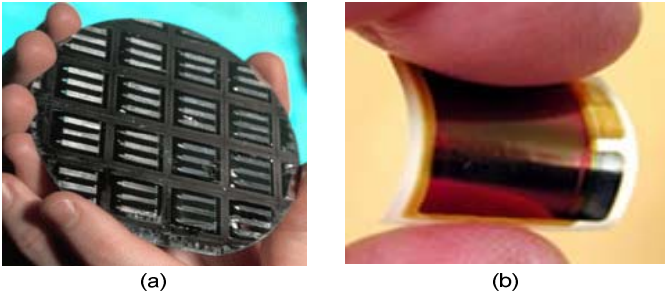

Fig. 2. (a) Micro-scale DMFC and (b) thin-film Li-Ion.

B. Thin-Film Li-Ion: Li-Ions are capable of supplying the power densities their DMFC counterparts cannot (Table I and Fig. 3). Consequently, under relatively heavy loading conditions and similar volume constraints, Li-Ions outlast FCs (but not under light loading conditions). Li-Ions also respond faster to load transient events, making them more suitable for higher power and fast-changing loads, which is why they have amassed so much market space and popularity.

TABLE I. MICRO-ENERGY SOURCES

	Li Ion or Li Polymer	Thin-film Li Ion	Micro Fuel Cell	Ultra Capacitor
Integration	Discrete	In Package	In Package	Discrete
Energy Density	150 W.hr/kg	200 W.hr/kg	1000 W.hr/kg	2 W.hr/kg
Self-Discharge Rate	2% per Month	1% per Year	Limited by Methanol Crossover	10% per Day
Cycle Life	~ 1,000	> 10,000	Limited by Membrane Degradation	> 100,000
Power Density	150 W/kg	200 W/kg	10 W/kg	20 kW/kg
Temperature Range	-40 to 65 °C	-25 to 120 °C	50 to 130 °C	-40 to 70 °C
Transient Response	0.1-10 ms	0.1-1 ms	0.01-1 s	1-10 μs
Cost	Low	Moderate	High	Moderate

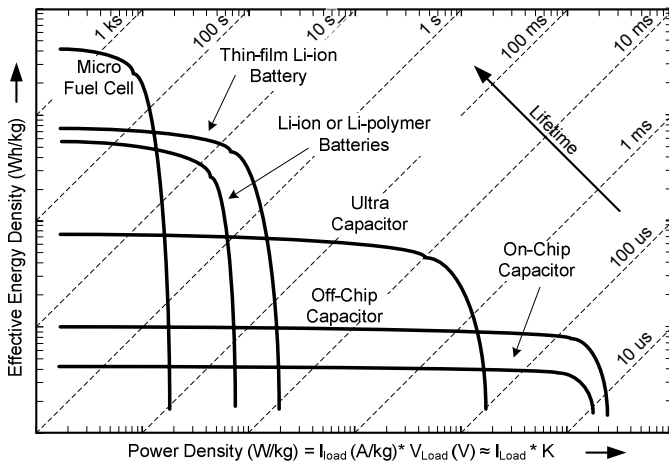

Fig. 3. Ragone plot: energy and power densities of various devices [15-16].

A thin-film Li-Ion (Fig. 2(b)) uses a solid-state nitrated phosphate glass (e.g., LiPON) as its electrolyte and can therefore sustain high temperature processing steps during fabrication (250 °C), which allows it to be deposited onto silicon wafers via vacuum deposition [10-13]. Because the processing medium is compact, higher energy and power densities are achieved when compared to conventional Li-Ions [14]. Even then, its energy density is 5-10 times below those of FCs.

III. POWER MANAGEMENT

Although both DMFCs and thin-film Li-Ions conform to micro-scale dimensions, their electrical characteristics are complementary: DMFCs are good for low slow-responding load levels and Li-Ion for high fast-responding loads. Ultimately, capacitors must supply instantaneous power, although ultra capacitors are relatively slow in this regard. An ideal hybrid source would therefore draw low steady-state power levels from a FC, higher DC and time-dependent levels from a Li-Ion, and instantaneous peak power levels from capacitors.

A. Loads: For constant loads, the optimum energy source should sustain the power and energy levels demanded under minimum space constraints (highest volume density). Conventionally, the sourcing technology is sized to deliver the power and energy needed, which is practical but often not optimal. For instance, referring to Fig. 4(a), constant low power load P_1 with short duration t_1 (point A) is best supplied by a Li-Ion because volume is more constrained by power than energy (energy density is low and power density is high at A, and Li-Ions have higher power density). The critical time boundary beyond which a FC is preferred occurs when the constraints of energy and power on volume by the two technologies equal, that is, the point where their energy-to-power density ratios equal or their energy-power profiles intersect (through critical time t_{Cr} in Fig. 4(a)). Consequently, if low power load P_1 were to be sustained for extended time t_2 (B: t_2 is longer than t_{Cr}), a FC requires less volume to sustain the load. As with A, for higher load P_2 and short duration t_1 (C), a Li-Ion conforms best to low volume because, even though its energy density is a bit strained, the FC's power density would be more strained and require more space. For higher load P_2 and extended time t_2 (D), the FC is best, even though its power levels are strained, because a Li-Ion would have occupied more space to store the energy required.

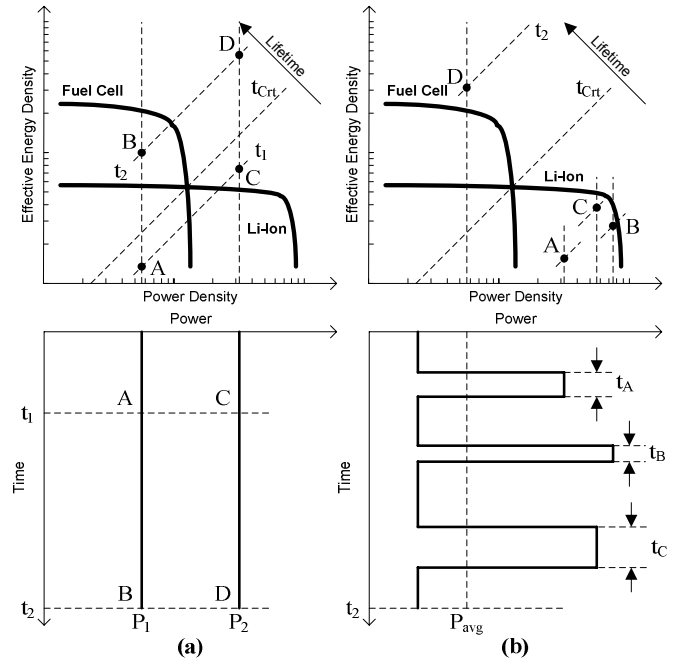

Fig. 4. Energy source mappings for (a) constant and (b) time-dependent loads.

Selecting technologies for time-dependent loads, as in most mobile applications, is involved. Fig. 4(b) illustrates a typical load train for a mixed-signal, power-moded portable application. A single source would be sized to supply both enough energy (average power P_{avg} for duration t_2) and enough peak power (pulse B), and one requirement normally overwhelms the other, the end result of which is worst-case volume demands. Decoupling these two parameters allows the designer to make more efficient use of space. For instance, the FC can

best supply P_{avg} for duration t_2 because energy is relatively more constrained than power. The Li-Ion can therefore be sized to supply the portion of the load that is most constrained by power (i.e., pulses and points A, B, or C). Generally, high PAPR (high P_{peak}/P_{avg}) applications benefit most from hybrid sources. If P_{avg} were higher or duration shorter than t_{Cr} in Fig. 4(b), for instance, a single Li-Ion would most efficiently supply the load.

B. Energy and Power Conditioning: Most mobile applications (e.g., cell phone) exhibit high PAPRs because they mostly idle (low average power P_{avg}) and, when fully powered, demand high peak power (P_{peak}), as in the case of wireless transmission. The FC can therefore source P_{avg} and the Li-Ion P_{peak} . When load power P_{Load} is below P_{avg} , however, the FC continues to supply P_{avg} but the difference ($P_{avg}-P_{Load}$) is used to charge the Li-Ion. Conversely, when P_{Load} is above P_{avg} , P_{Load} is supplied by both the FC and the Li-Ion. Since FCs respond more slowly, an ideal hybrid solution keeps the load to the FC constant at P_{avg} (averaged over the lifespan of the device) and derives the difference from a Li-Ion (and a capacitor).

In implementing the proposed scheme, a boosting current regulator is used to condition and fix the FC load to P_{avg} (i.e., fixing FC current I_{FC} also fixes FC voltage V_{FC}) and a bucking voltage regulator to fix and regulate output voltage V_{OUT} to, say, 1.8V, the supply voltage required to power a wireless sensor (Fig. 5). A boosting function is needed to charge a 2.7-4.2V thin-film Li-Ion because V_{FC} is approximately 0.2-0.6V. A bucking function is used at the output because regulated V_{OUT} (1.8V), in the case shown, is always below the minimum Li-Ion voltage (2.7V). An additional boosting 0.2-0.6V to 1.8V function is added from the FC to the load to bypass the Li-Ion during heavy loading conditions. Protection circuitry is also included to prevent the Li-Ion from over- or under-charging conditions, which would be detrimental to the Li-Ion.

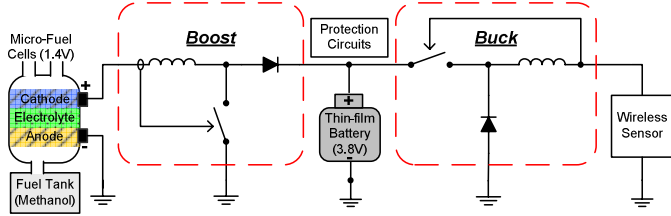

Fig. 5. Hybrid FC-Li-Ion energy- and power-conditioning system.

The thin-film Li-Ion acts like a power *cache* between the MEMS DMFC and the wireless sensor load. Depending on load level, the Li-Ion either absorbs the extra energy (charges) not used by the load or supplies the additional energy required (discharges). For instance, if P_{Load} is below P_{avg} , the buck regulator only demands P_{Load} (plus a few losses) and the difference in power (in the form of current) is consequently channeled to the Li-Ion, like a “wired-or” function. When P_{Load} is above P_{avg} , on the other hand, all FC power is directed to the load via the bucking regulator, plus whatever additional power may be required from the Li-Ion to fully sustain the load.

IV. LIFETIME

A. Macro-Models: To evaluate and predict system and lifetime performance, simulations and supporting macro-models are required. Detailed macro-models are preferred over transistor-level circuits because 6-12 month lifetime simulations incur significant computational time. Scaled micro-scale FC and thin-film Li-Ion circuit-based models are derived from [17-18] and current and voltage regulator functions built with behavioral Verilog-A tools. The system was simulated with Cadence, a standard platform for integrated circuit design.

The micro-scale FC model in [17] is shown in Fig. 6, where the total energy is modeled by a charged capacitor, methanol crossover by a

self-discharging resistor, open-circuit voltage by a nonlinear dependent voltage source, and series voltage drop and transient response by an RC network with asymmetrical response (C is one value when presented with a positive load dump and another with a negative dump). Since the ongoing 40uA micro-scale MEMS DMFC uses a similar membrane and system configuration as the commercial 10mA tank-supplied DMFC in [17], and the only difference is the membrane area – 250x, the commercial DMFC looks like a parallel combination of 250 MEMS DMFCs. The model was downscaled from 10mA (commercial DMFC with decreasing methanol concentration) to 40uA (micro-scale MEMS DMFC) by a factor of 250, that is, all resistors were increased and capacitors (except for $C_{Capacity}$) decreased by a 250 factor to preserve the same time constants. Since the energy density of the DMFC is determined by the amount of fuel in the tank, a total of 550J is assumed for 0.5cm³ 8M methanol with 40% efficiency. $C_{Capacity}$ is determined by dividing energy by the nominal FC voltage (0.5V) and normalizing it to one (state-of-charge voltage V_{SOC} is 1V), which gives 1100F. The other parameters were unchanged. The thin-film Li-Ion model in [18] (shown in Fig. 7) is a simplified version of the DMFC, where C no longer has an asymmetrical capacitance value. Similarly, the model was downscaled by a factor of 1600 on the basis of Amp-hour ratios (800mAh of the commercial battery tested to the projected 500uAh of the thin-film Li-Ion), which is to say all resistors were increased and capacitors decreased by 1600.

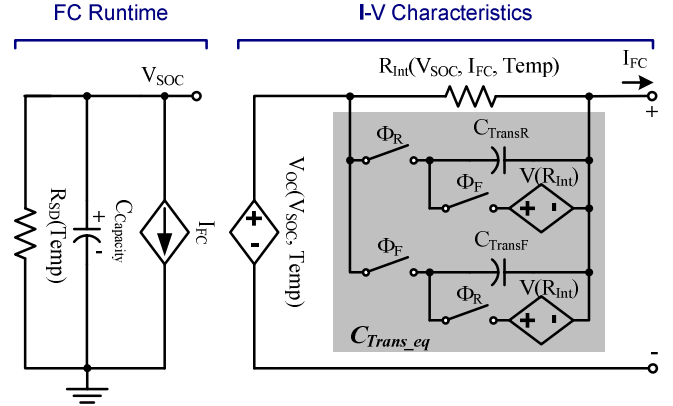

Fig. 6. Micro-scale FC model.

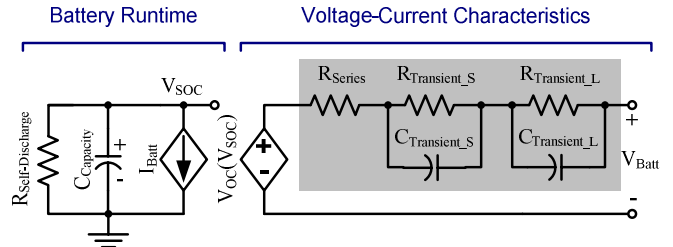

Fig. 7. Thin-film Li-Ion model.

The proposed system has several power paths: from the DMFC to the Li-Ion, from the Li-Ion to the load, and from the DMFC directly to the load. The DMFC-Li-Ion path is a boosting 0.5-3.6V function whose efficiency is assumed to be 75% (typical boosting efficiency). The Li-Ion-load path is a bucking 3.6-1.8V regulator with a typical efficiency of 90%. Finally, the DMFC-load path is conditioned with a boosting 0.5-1.8V circuit with a typical efficiency of 80% (η_{direct}).

B. Load Profile: Key load parameters are the peak current, duty cycle, average current, pulse-width duration, and period of the various functions comprising the system. For example, the load profile described in Table II calls for three different sensors (e.g., temperature, pressure, and EMI) working at three different duty cycles and under various operational frequencies. Data is stored and telemetry is only engaged when needed, once a day at 0.07% duty cycle. As with any

system, some vital monitoring and biasing functions operate throughout the life of the device T_{Life} (i.e., 100% duty cycle). T_{Life} is ultimately determined by the average load power (average load current I_{OUT_avg}), total energy available in the FC (E_{FC}), the percentage of power delivered to the load via the Li-Ion (k), and the FC-load (η_{direct}) and FC-Li-Ion-load ($\eta_{indirect}$) efficiencies of the circuit:

$$E_{OUT} = E_{FC\%} [(1-k)\eta_{direct} + k\eta_{indirect}] = V_{OUT} I_{LOAD_avg} T_{Life}, \quad (1)$$

and if T_{Life} is set to 1 year, usable energy $E_{FC\%}$ to 550J (1375J methanol with 40% chemical-to-electrical FC efficiency), η_{direct} to 80%, $\eta_{indirect}$ to 67.5% ($\eta_{indirect} = \eta_{FC-Li-Ion} \eta_{Li-Ion-Load}$: FC to Li-Ion is 75% and Li-Ion to load 90%), and k is 0.5, the system can sustain up to 12.8 μ W of average load power:

$$P_{LOAD} = V_{OUT} I_{OUT_avg} = \frac{E_{FC\%} [(1-k)\eta_{direct} + k\eta_{indirect}]}{T_{Life}} \approx 12.8\mu W \quad (2)$$

or 7.1 μ A of average current at a V_{OUT} of 1.8V.

TABLE II. LOAD PROFILE: SCENARIO 1.

Scenario 1	Sensor 1	Sensor 2	Sensor 3	Telemetry	Vitals
Peak Current	1 μ A	10 μ A	200 μ A	1mA	3.15 μ A
Duty Cycle	80%	5%	1%	0.07%	100%
Average Current	0.8 μ A	0.5 μ A	2 μ A	0.7 μ A	3.15 μ A
Pulse Width	2.88ks	1.8ks	600s	60s	36ks
Period	3.6ks	36ks	60ks	86.4ks	36ks

C. Simulations: Fig. 8 shows the lifetime performance of the foregoing system under various FC currents I_{FC} for the load described in Table II. When I_{FC} is fixed to 30 μ A, usable input power is below average load power P_{LOAD} (i.e., 30 μ A \cdot 0.5V \cdot [(1-k) η_{direct} +k $\eta_{indirect}$] = 11.06 μ W < 12.8 μ W) and lifetime is only 18 days (Li-Ion is completely discharged in 18 days and can no longer sustain peak load power levels). When I_{FC} is 44 μ A, however, usable input power (16.23 μ W) is above P_{LOAD} and T_{Life} is 318 days (Li-Ion is kept charged 318 days).

Lifetime is sensitive to I_{FC} when usable FC power (efficiency-derated P_{FC}) is near output power. The sensitivity decreases as usable power is raised above P_{LOAD} . However, if I_{FC} is raised above the FC's rated current, that is, beyond its power-density limit where energy density is low (Fig. 3), lifetime again decreases. As a result, regulated micro-scale FC current I_{FC} has an optimum range of operation.

V. CONCLUSIONS

In managing micro-scale system-in-package (SiP) devices, not only is power conditioning necessary to supply the load but also energy conditioning to extend lifetime, which is why an energy- and power-management scheme for a hybrid micro-scale MEMS FC-thin-film Li-Ion source and its design methodology have been proposed, presented, modeled, and simulated within the context of a wireless multi-sensor SiP application. The key feature of the proposed scheme is how to ascertain the optimal volume-space allocation of a hybrid micro-scale source to achieve the peak-power, average-power, and lifetime demands of a load. In the wireless-sensor application studied, the FC supplies the average power of the system because its energy density is only high at lower power levels and its response time to transient load changes is slow. The Li Ion supplies burst power because its energy density is higher at higher power levels and its response time is faster. A hybrid solution, in the end, however, is only warranted when loaded with high peak-to-average power ratios (PAPRs), when the energy and power density limits of a source are disproportionately strained, which is often the case in state-of-the-art portable devices where functions are duty-cycled to save power and extend life.

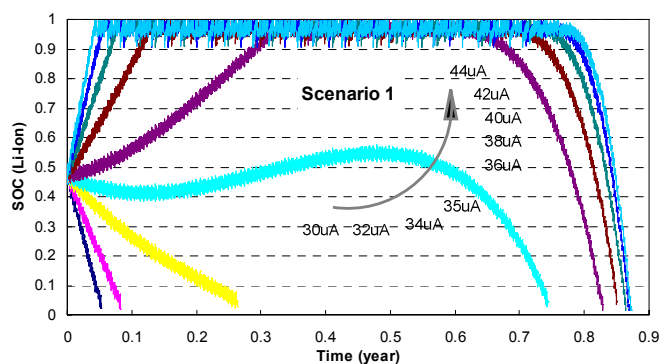

Fig. 8. Lifetime: Li-Ion's state-of-charge (SOC) for various I_{FC} 's.

REFERENCES

- [1] G.E. Moore, "Cramming more components onto integrated circuits," *Electronics*, vol. 38, no. 8, April 19, 1965.
- [2] E.O. Torres and G.A. Rincón-Mora, "Long lasting, self-sustaining, and energy-harvesting system-in-package (SiP) sensor solution," in *International Conference on Energy, Environment, and Disasters (INCEED)*, Charlotte, NC, July, 2005.
- [3] Z. Jiang and R.A. Dougal, "A compact digitally controlled fuel cell/battery hybrid power source," *IEEE Transaction on Industrial Electronics*, vol. 53, no. 4, Aug. 2006, pp. 1094-1104.
- [4] K. Jeong, W. Lee, and C. Kim, "Energy management strategies of a fuel cell/battery hybrid system using fuzzy logics," *Journal of Power Sources*, vol. 145, issue 2, 2005, pp. 319-326.
- [5] C.W. Moore, J. Li, and P.A. Kohl, "Microfabricated fuel cells with thin-film silicon dioxide proton exchange membranes," *Journal of the Electrochemical Society*, vol. 152, no. 8, Aug. 2005, pp. A1606-1612.
- [6] R.F. Savinell, J.S. Wainright, L. Dudik, and C.C. Liu, "Recent advances in microfabricated fuel cells," *New Materials for Electrochemical Systems*, 2001, pp. 371-372.
- [7] T.J. Yen, N. Fang, X. Zhang, G.Q. Lu, C.Y. Wang, "A micro methanol fuel cell operating at near room temperature," *Applied Physics Letters*, vol. 83, no. 19, 10 November 2003.
- [8] EG&G Technical Services, Inc., Science Applications International Corporation, *Fuel Cell Handbook (Sixth Edition)*. Morgantown, VA: U.S. Department of Energy, Office of Fossil Energy, National Energy Technology Laboratory, November, 2002.
- [9] G. Hoogers, *Fuel Cell Technology Handbook*. Boca Raton, FL: CRC Press, 2003.
- [10] J. Klassen, "A description of Cymbet battery technology and its comparison with other battery technologies," [Online]. Available: <http://www.cymbet.com/>
- [11] R.P. Raffaele, J.D. Harris, D. Hehemann, D. Scheiman, G. Rybicki, A.F. Hepp, "A facile route to thin-film solid state lithium microelectronic batteries," *Journal of Power Sources*, vol. 89, no. 1, Jul, 2000, pp. 52-55.
- [12] J.B. Bates, N.J. Dudney, B. Neudecker, A. Ueda, C.D. Evans, "Thin-film lithium and lithium-ion batteries," *Solid State Ionics*, vol. 135, no. 1-4, Nov, 2000, pp. 33-45.
- [13] J.L. Souquet, M. Duclot, "Thin film lithium batteries," *Solid State Ionics*, vol. 148, no. 3-4, June, 2002, pp. 375-379.
- [14] D. Linden, T.B. Reddy, *Handbook of Batteries (Third Edition)*. New York: McGraw-Hill, 2002.
- [15] T. Christen and M. W. Carlen, "Theory of Ragone plots," *Journal of Power Sources*, vol. 91, no. 2, Dec. 2000, pp. 210-216.
- [16] T. Christen and C. Ohler, "Optimizing energy storage devices using Ragone plots," *Journal of Power Sources*, vol. 110, no. 1, July 2002, pp. 107-116.
- [17] M. Chen and G.A. Rincón-Mora, "A Compact Electrical Model for Micro-Scale Fuel Cells Capable of Predicting Runtime and I-V Polarization Performance," *IEEE Transactions on Energy Conversion*, in Press.
- [18] M. Chen and G.A. Rincón-Mora, "Accurate Electrical Battery Model Capable of Predicting Runtime and I-V Performance," *IEEE Transactions on Energy Conversion*, vol. 21, no. 2, June 2006, pp. 504-511.