



Intersil's ISL60007 delivers typical power consumption of just 1.08 $\mu$ -Watt and...



## Self-powered chips - The work of fiction

By Gabriel A. Rincón-Mora, Senior Member, IEEE, and Min Chen, Student Member, IEEE; Georgia Tech Analog and Power IC Design Laboratory

[Power Management DesignLine](#)

Apr 28, 2005 (3:04 PM)

URL: <http://www.planetanalog.com/showArticle?articleID=162100756>

The rapid growth of information, communication, and fabrication technologies is driving the semiconductor industry to unprecedented levels [1-2], flooding the market with an extensive array of novel consumer, medical, and industrial electronic devices [3]. Emerging portable micro-power applications like sensors, meters, GPS, implantable electronics, and others continue to push technology to cater to small, long lasting, low cost, and fully integrated solutions, fueling the demand for system-on-chip (SoC) and system-in-package (SiP) integration. The semiconductor industry has responded to this demand by increasing the functional density of integrated circuits (ICs), promising to integrate most of the microelectronics necessary to support a system into a single chip. Some of the most notable SoC and SiP challenges of today still include the integration of power passive and active components (e.g., power inductors, capacitors, and transistors) and radio-frequency (RF), broadband-frequency, and power technologies into a single chip, but nothing compares to the limitations of integrating batteries and power sources into the chip, which, if successful, would reduce weight, shrink size, increase mobility, and hopefully extend operation life.

Outside of housekeeping functions, there are three basic functional blocks to a system: power source, energy storage devices, and loading applications. For a cellular phone, for instance, the ac-power outlet is the power source, the battery the energy-storage device, and the transceiver one of its loading applications. These blocks interrelate and function via various power management circuits, which range from protection and monitoring to regulating functions. The most critical functions, however, are to charge and regulate, as illustrated in Figure 1. Chargers collect, manipulate, and transfer energy from the source to the storage device and regulators massage and deliver the energy stored to the load. Consequently, true SiP solutions must house all power sources, energy storage devices, loading applications, chargers, and regulators in a single chip, which is no trivial task.

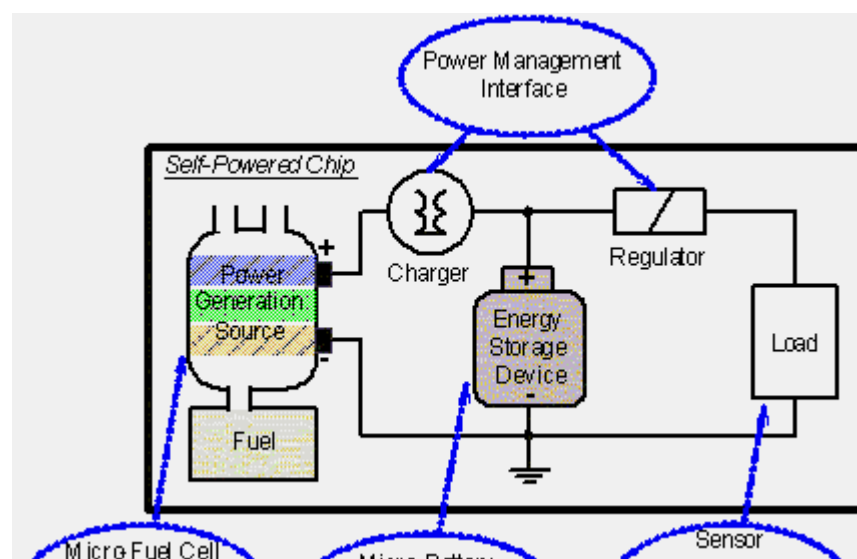



Figure 1. A micro-power system-in-package (SiP) solution

Micro-Power Sources Chip-compatible power sources, in other words, power sources that can be co-packaged in situ with the IC are scarce. Not only physical but also energy-density constraints prevent many technologies from breaking this SiP paradigm. Recent research shows photovoltaic cells, thin-film lithium-ion batteries, and some energy-harnessing micro-electromechanical system (MEMS) devices can be packaged alongside the electronics that support them. Unfortunately, the combination of their relatively low energy density with the limited volume-space available in a chip make them unsuitable for practical system solutions, which is why micro-fuel cells are enjoying some popularity in research circles.

Direct methanol fuel cells (DMFC) have a theoretical energy density five to ten times higher than lithium-based chemistries (Figure 2), giving rise to significantly longer lifetimes [4-6]. The micro-fuel cell, which is an integrated DMFC, is fabricated on a silicon wafer by means of a MEMS process technology [7-8]. Although still at infant stages of development, these fuel cells promise to supply significantly more energy than any other technology in the same volume-space. High energy density, low environmental intrusion, and reasonable operating temperatures (i.e., ambient) are attractive features, but most important of all is chip integration. The main drawback of this technology is limited power density; in other words, the range of power for which the device is useful is low. An inherently high internal resistance impedes its ability to supply high power, thereby preventing it from handling relatively high "burst" load currents, which occur often in a mixed-signal environment like the cellular phone. Initial cost is also a drawback, given the use expensive rare metal catalysts and the requirement of complex electromechanical controls, like fuel supply, membrane hydration, and heat regulation [5-6].

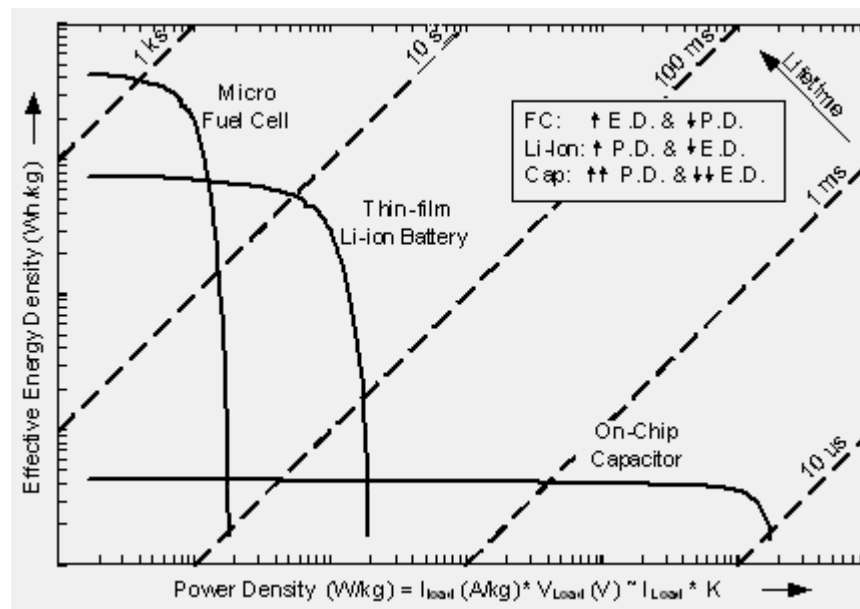

Figure 2. Ragone plots (energy/power density curves) of various power sources and energy storage devices.

### Micro- Storage Devices

Energy-storage devices suffer from similar physical and energy- and power-density limitations. Since the function of storage is complementary and not technically equivalent to the source, power density is more important than energy density. For instance, the source must consider the storage device but not necessarily the load, which is why energy is the most important parameter of the source, for battery life. On the other

hand, the storage unit in the system of Figure 1 must consider the loading demands of the system, which manifest themselves in the form of power. Power density is therefore the primary concern of the load and an important feature of the energy-storage device.

Thin-film lithium-ion (Li-Ion) batteries [9-11] are not only SiP compatible but they also have relatively high power density, low self-discharge, reasonable operating temperatures, and long cycle life. Their ability to be fabricated in thin sheets combined with the increasing capabilities of packaging technologies promise to solve some of the chip-integration issues of the self-powered chip paradigm. These batteries can handle the "burst" power load demands that micro-fuel cells are incapable of satisfying. They will not, however, source ultra-fast load currents, which only capacitors (also energy-storage devices) can supply. Capacitors, unfortunately, only store limited energy levels, as illustrated in Figure 2, and they therefore complement and not replace batteries. Plus, only on-chip and in-package capacitors are considered in SiP solutions, and they only range up to a few hundred pico-Farads, and that is only if enough silicon real estate is allocated to them, which is not a luxury most designers can enjoy.

A self-powered chip is consequently limited to SiP-compatible components, which include micro-fuel cells, MEMS generators, photovoltaic cells, thin-film Li-Ion batteries, and on-chip and in-package capacitors (Figure 1). Given the energy and density demands of the system, fuel cells can supply the most energy and thin-film Li-Ion batteries the most power, and capacitors instantaneous power. The question that remains is how to use and integrate these components to efficiently transfer and regulate the energy delivered to the loading application.

### Handling the Load

Most micro-power applications are mixed signal in nature, requiring both steady-state and clocked power. What is more, these systems are power-moded to decrease energy use and extend operation life. For instance, a cellular phone is designed to stay in either off, idle, or low- or high-performance mode, and power is only demanded when the user demands it (i.e., making or receiving a call). Each of these modes is in turn defined by DC and clocked load-current demands, as shown in Figure 3. The power management circuits, or the "brain" and "housekeeper" of the system, must therefore regulate and supply all of the power demanded by the system, transferring enough energy to storage and delivering it to the load in a power- and energy-efficient manner, which is critical for long operation life.



[Figure 3. A typical pulse-power load profile of portable micro-power applications chip](#)

Given the complementary energy-power characteristics of the source and storage devices and the growing operational life demands of consumer and state-of-the-art applications, no single source or storage device is best suited to handle the load fully [12-13]. The load is consequently partitioned into high "burst," fast "transient," and steady-state regions (Figure 3) and supplied by a combination of source and storage devices, i.e., by a hybrid solution. Fuel cells, for instance, supply low steady-state loads because they have the most energy in the low power region. Li-Ion batteries, on the other hand, are best suited for high burst loads, where more energy can be found than in fuel cells (Figure 2). Capacitors, of course, supply current during fast load-transient events.

Micro-fuel cells essentially source the average power required by the system and, when the load drops below this point, which happens in Mode 1 in Figure 3, the difference is used to charge the Li-Ion battery. Conversely, when the load exceeds the average output power of the fuel cells (Mode 2), the Li-Ion battery supplies the difference. The end result is a hybrid solution that is capable of handling both low and high load currents while simultaneously maximizing the usable energy for each of these power levels, thereby

extending operation life.

### Proposed Solution

We therefore propose the self-powered, system-in-package (SiP) solution illustrated in Figure 4, which is comprised of in-package micro-fuel cells, thin-film Li-Ion batteries, capacitors, and a power management control IC, all in a single package. Two or three fuel cells in series are used to generate practical supply voltage levels (e.g., 1.2-2.1V) and supply the average power required by the system. The thin-film Li-Ion battery can be placed above the IC or below, interconnected with bondwires to the leadframe. The silicon die houses the fuel tank and gravity keeps the fuel pressure constant in a flip-chip configuration. Obviously, the proposed system presents many challenges but its potential is attractive for a wide range of portable electronics applications like sensor networks and biomedical implantable devices, possibly overcoming the SiP paradigm and consequently pushing technology into the next decade. At present, we are modeling fuel cells and Li-Ion batteries to ultimately design and prototype suitable chargers and regulators.

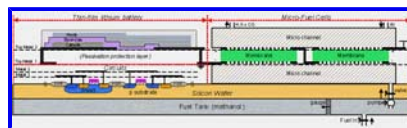

[Figure 4. Proposed hybrid, self-powered system-in-package \(SiP\) chip](#)

For additional details, questions, and/or comments on this article, please contact us, the Georgia Tech Analog and Power IC Design Lab, at [gtap@ece.gatech.edu](mailto:gtap@ece.gatech.edu).

More information about our research can be found at [www.ricon-mora.com/research](http://www.ricon-mora.com/research).

### References:

- [1] Gordon E. Moore, "Cramming more components onto integrated circuits," *Electronics*, Vol. 38, No. 8, April 19, 1965.
- [2] Expanding Moore's Law: The Exponential Opportunity, Intel, Fall 2002. Available: <http://www.intel.com/>
- [3] N. Andrews, "The global market for power supply and power management integrated circuits," in *Applied Power Electronics Conference and Exposition*, 2002.
- [4] D. Linden, T. B. Reddy, *Handbook of Batteries* (Third Edition). New York: McGraw-Hill, 2002.
- [5] EG&G Technical Services, Inc., Science Applications International Corporation, *Fuel Cell Handbook* (Sixth Edition). Morgantown, VA: U.S. Department of Energy, Office of Fossil Energy, National Energy Technology Laboratory, November, 2002.
- [6] G. Hoogers, *Fuel Cell Technology Handbook*. Boca Raton, FL: CRC Press, 2003.
- [7] T. J. Yen, N. Fang, X. Zhang, G. Q. Lu, C. Y. Wang, "A micro methanol fuel cell operating at near room temperature," *Applied Physics Letters*, vol. 83, no. 19, 10 November 2003.
- [8] R. Dillon, S. Srinivasan, A.S. Arico, V. Antonucci, "International activities in DMFC R&D: status of technologies and potential applications," *Journal of Power Sources*, vol. 127, no. 1-2, pp. 112-26.
- [9] J. B. Bates, N. J. Dudney, B. Neudecker, A. Ueda, C. D. Evans, "Thin-film lithium and lithium-ion batteries," *Solid State Ionics*, vol. 135, no. 1-4, pp. 33-45.
- [10] J. Klassen, "A description of Cymbet battery technology and its comparison with other battery technologies," *White Paper*, Cymbet Corporation. Available: <http://www.cymbet.com/>
- [11] J. L. Souquet, M. Duclot, "Thin film lithium batteries," *Solid State Ionics*, vol. 148, no. 3-4, pp. 375-379.
- [12] R. M. Schupbach, J. C. Balda, M. Zolot, B. Krammer, "Design methodology of a combined battery-ultracapacitor energy storage unit for vehicle power management," *IEEE Annual Power Electronics Specialists Conference*, vol. 1, pp. 88-93, 2003.
- [13] L. P. Jarvis, P. J. Cygan, M. P. Roberts, "Fuel cell/Lithium-Ion battery hybrid for manportable applications," *Proceedings of seventeenth Annual Battery Conference on Applications and Advances*, 2002, pp. 69-72.

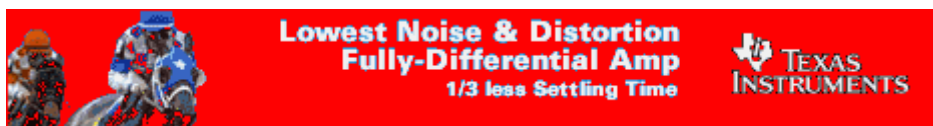

**Lowest Noise & Distortion**  
**Fully-Differential Amp**  
1/3 less Settling Time



[Copyright © 2003 CMP Media, LLC](#) | [Privacy Statement](#)