

# ECE 3040 HW 7

1. Assume  $V_{TN} = 0.5 \text{ V}$ ,  $k'_n = \mu_n C_{ox} = 100 \frac{\mu\text{A}}{\text{V}^2}$ ,  $\frac{W}{L} = 28$

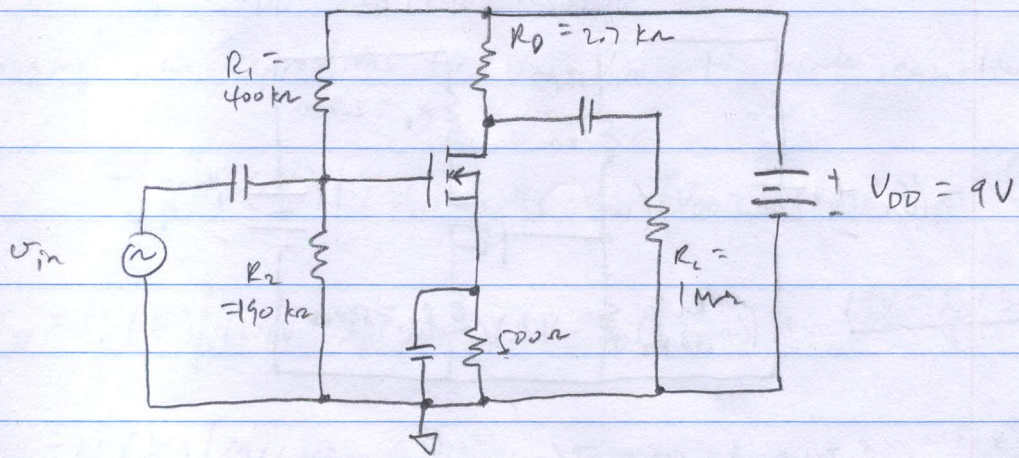

a) assume transistor is in cutoff, find Q-pt.

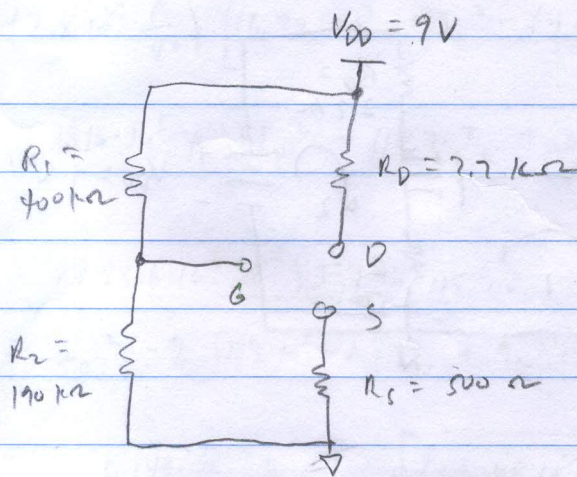

$$I_D = 0$$

$$V_D = 9 \text{ V}$$

$$V_G = (9 \text{ V}) \left( \frac{190 \text{ k}\Omega}{400 \text{ k}\Omega + 190 \text{ k}\Omega} \right) = 2.90 \text{ V}$$

$$V_S = 0 \text{ V}$$

$$V_{DS} = 9 \text{ V}$$

$$V_{GS} = 2.90 \text{ V}$$

$$Q\text{-pt} = (I_D, V_{DS})$$

$$V_{DS} > V_{GS} - V_T$$

$$9 \text{ V} > 2.4 \text{ V}$$

assumption untrue

$$Q\text{-pt} = (0 \text{ A}, 9 \text{ V})$$

b) assume transistor is in triode

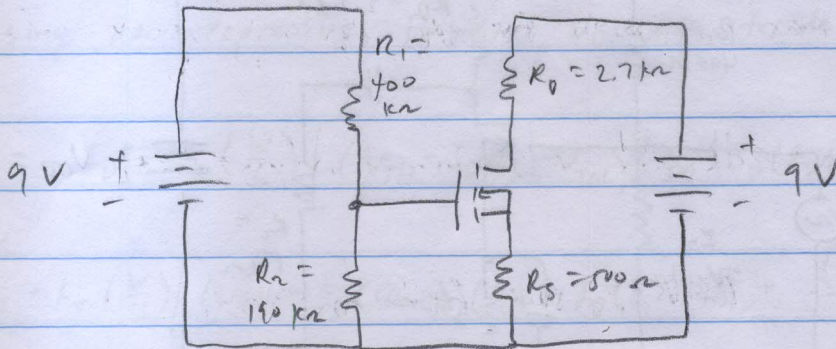

$$V_{TH} = (9V) \left( \frac{190k\Omega}{400k\Omega + 190k\Omega} \right) = 2.90V$$

$$R_{TH} = R_1 \parallel R_2 = 400k\Omega \parallel 190k\Omega = 128.8k\Omega$$

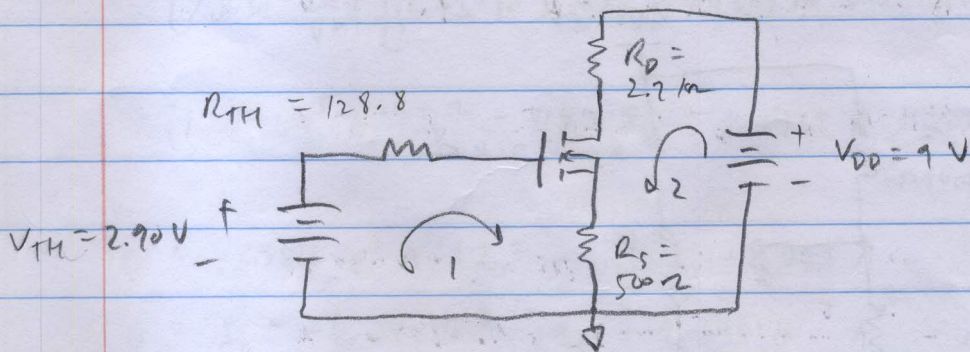

$$V_G = 2.90V$$

KVL Loop 1

$$V_{TH} = V_{GS} + I_D R_S$$

KVL Loop 2

$$V_{DD} = I_D R_D + V_{DS} + I_D R_S$$

triode

$$I_D = k'_n \left( \frac{W}{L} \right) \left[ (V_{GS} - V_{TN}) V_{DS} + \frac{V_{DS}^2}{2} \right]$$

using Loop 1 to solve for  $V_{GS}$

$$V_{GS} = V_{TH} - I_D R_S$$

using Loop 2 to solve for  $V_{DS}$

$$V_{DS} = V_{DD} - I_D (R_D + R_S)$$

plugging new expressions for  $V_{GS}$ ,  $V_{DS}$  into triode equation:

$$I_D = k'_n \left( \frac{W}{L} \right) \left[ (V_{TH} - I_D R_S - V_{TN}) (V_{DD} - I_D (R_D + R_S)) + \frac{(V_{DD} + I_D (R_D + R_S))^2}{2} \right]$$

$$I_D = k'_n \left( \frac{W}{L} \right) \left[ (2.4V - I_D (500\Omega)) (9V - I_D (3.2k\Omega)) + \frac{(9V - I_D (3.2k\Omega))^2}{2} \right]$$

$$= k'_n \left( \frac{W}{L} \right) \left[ (21.6V^2 - (1.218 \cdot 10^4 V \cdot \Omega) I_D + (1.6 \cdot 10^6 \Omega^2) I_D^2 + \frac{81V^2 - (5.76 \cdot 10^4 V \cdot \Omega) I_D + (1.024 \cdot 10^7 \Omega^2) I_D^2}{2} \right]$$

$$= k'_n \left( \frac{W}{L} \right) \left[ (6.72 \cdot 10^7 \Omega^2) I_D^2 - (4.098 \cdot 10^4 V \cdot \Omega) I_D + 62.1 V^2 \right]$$

$$= (2.8 \cdot 10^3 \frac{A}{V^2}) \left[ (6.72 \cdot 10^7 \Omega^2) I_D^2 - (4.098 \cdot 10^4 V \cdot \Omega) I_D + 62.1 V^2 \right]$$

$$= (1.8816 \cdot 10^5 A^{-1}) I_D^2 - 114.7 I_D + 0.1739 A$$

$$0 = (1.8816 \cdot 10^5 A^{-1}) I_D^2 - 115.7 I_D + 0.1739 A$$

$$0 = I_D^2 - (6.149 \cdot 10^{-4} A) I_D + 9.242 \cdot 10^{-7} A^2$$

$$I_D = \frac{6.149 \cdot 10^{-4} A \pm \sqrt{(-6.149 \cdot 10^{-4} A)^2 - 4(9.242 \cdot 10^{-7} A^2)}}{2 A}$$

$I_D = \text{non real answers}$

assumption incorrect

c) same equivalent circuit and loop equations as triode solution.

$$V_{DS} = V_{DD} - I_D(R_D + R_S)$$

$$V_{GS} = V_{TH} - I_D R_S$$

$$\text{saturation current: } I_D = \frac{k'_n}{2} \left(\frac{W}{L}\right) (V_{GS} - V_{TN})^2$$

plugging expression for  $V_{GS}$  into  $I_D$

$$I_D = \frac{k'_n}{2} \left(\frac{W}{L}\right) (V_{TH} - I_D R_S - V_{TN})^2$$

$$= (1.4 \cdot 10^3 \frac{A}{V^2}) (2.4 V - I_D (500 \Omega))^2$$

$$= (1.4 \cdot 10^3 \frac{A}{V^2}) [5.76 V^2 - (2.4 \cdot 10^3 V \cdot \Omega) I_D + (2.5 \cdot 10^5 \Omega^2) I_D^2]$$

$$= (8.064 \cdot 10^{-3} A) - 3.36 I_D + (350 A^{-1}) I_D^2$$

$$0 = (350 A^{-1}) I_D^2 - 3.36 I_D + 8.064 \cdot 10^{-3} A$$

$$0 = I_D^2 - (1.246 \cdot 10^{-2} A) I_D + 2.304 \cdot 10^{-5} A^2$$

$$I_D = \frac{1.246 \cdot 10^{-2} \pm \sqrt{(-1.246 \cdot 10^{-2} A)^2 - 4(2.304 \cdot 10^{-5} A^2)}}{2}$$

$$= 6.23 \pm 3.97 \text{ mA} = 10.2 \text{ mA or } 2.26 \text{ mA}$$

arbitrarily test  $I_D = 10.2 \text{ mA}$  first

$$V_{DS} = 9 V - (10.2 \text{ mA})(3.2 \text{ k}\Omega) = -23.64 V$$

$$V_{GS} = 2.90 V - (10.2 \text{ mA})(500 \Omega) = -2.2 V$$

$$\boxed{V_{DS} < V_{GS} - V_T \quad \text{assumption untrue}} \\ -23.64 V < -2.2 V$$

$$I_D = 2.26 \text{ mA}$$

$$V_{DS} = 9 \text{ V} - (2.26 \text{ mA})(3.02 \text{ k}\Omega) = 1.77 \text{ V}$$

$$V_{GS} = 2.90 \text{ V} - (2.26 \text{ mA})(500 \Omega) = 1.77 \text{ V}$$

$$V_{DS} > V_{GS} - V_T$$

$$1.77 \text{ V} > 1.27 \text{ V} \quad \text{assumption true}$$

$$\text{Q-pt: } (2.26 \text{ mA}, 1.77 \text{ V})$$

d) saturation is valid assumption

$$e) \quad I_D = \frac{k'_n}{2} \left(\frac{W}{L}\right) (V_{GS} - V_{TN})^2 (1 + \lambda V_{DS}) \quad \lambda = 0.1 \text{ V}^{-1}$$

$$\begin{aligned} I_D &= \frac{k'_n}{2} \left(\frac{W}{L}\right) (V_{TH} - I_D R_S - V_{TN})^2 [1 + \lambda (V_{DD} - I_D (R_D + R_S))] \\ &= [(8.064 \cdot 10^{-3} \text{ A}) - 3.36 I_D + (350 \text{ A}^{-1}) I_D^2] [1 + 0.9 - (320 \text{ A}^{-1}) I_D] \\ &= (1.532 \cdot 10^{-2} \text{ A}) - 6.384 I_D + (665 \text{ A}^{-1}) I_D^2 - 2.580 I_D + (1.075 \cdot 10^3 \text{ A}^{-1}) I_D^2 \\ &\quad - (1.12 \cdot 10^5 \text{ A}^2) I_D^3 \end{aligned}$$

$$0 = -(1.12 \cdot 10^5 \text{ A}^2) I_D^3 + (1.740 \cdot 10^3 \text{ A}^{-1}) I_D^2 - 9.964 I_D + (1.532 \cdot 10^{-2} \text{ A})$$

$$\begin{aligned} 0 &= I_D^3 - (1.554 \cdot 10^{-2} \text{ A}) I_D^2 + (8.896 \cdot 10^{-5} \text{ A}^2) I_D - (1.368 \cdot 10^{-7} \text{ A}^3) \\ &= I_D^3 + p I_D^2 + q I_D + r \end{aligned}$$

$$\text{let } a = \frac{1}{3}(3q - p^2) = 8.463 \cdot 10^{-6} \text{ A}^2$$

$$b = \frac{1}{27}(2r^3 - 9pq + 27r) = 4.603 \cdot 10^{-8} \text{ A}^3$$

$$\text{let } A = \sqrt[3]{-\frac{b}{2} + \sqrt{\frac{b^2}{4} + \frac{a^3}{27}}} = 7.844 \cdot 10^{-4} \text{ A}$$

$$12 + \\ B = -\sqrt[3]{+\frac{b}{2} + \sqrt{\frac{b^2}{4} + \frac{a^3}{27}}} = -3.596 \cdot 10^{-3} \text{ A}$$

$$x = A + B = -2.812 \cdot 10^{-3} \text{ A} \rightarrow \text{real}$$

or

$$x = -\frac{A+B}{2} + \frac{A-B}{2}\sqrt{-3} =$$

or

$$x = -\frac{A+B}{2} - \frac{A-B}{2}\sqrt{-3} =$$

} complex

use  
real  
root

$$I_D = y = x + \frac{p}{3} = -2.812 \cdot 10^{-3} \text{ A} - \frac{(-1.554 \cdot 10^{-2} \text{ A})}{3}$$

$$I_D = 2.368 \text{ mA}$$

$$V_{DS} = 9 \text{ V} - (2.368 \text{ mA})(3.2 \text{ k}\Omega) = 1.422 \text{ V}$$

$$V_{GS} = 2.90 \text{ V} - (2.368 \text{ mA})(500 \Omega) = 1.716 \text{ V}$$

$$Q\text{-pt: } (2.368 \text{ mA}, 1.422 \text{ V})$$

$$V_{DS} > V_{GS} - V_{TN}$$

$$1.422 \text{ V} > 1.216 \text{ V}$$

saturation assumption verified

f)

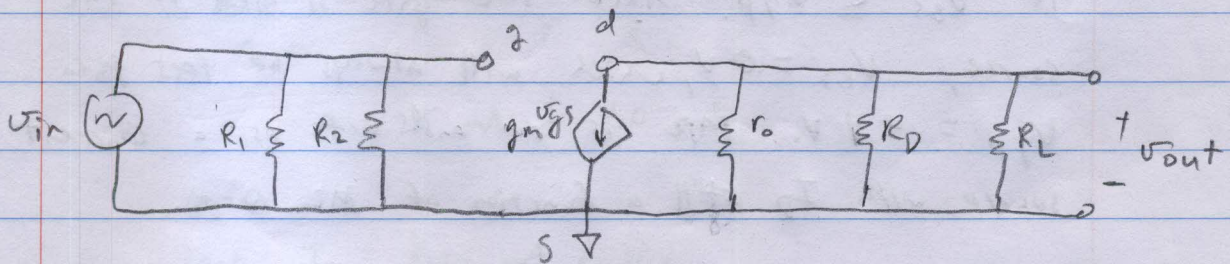
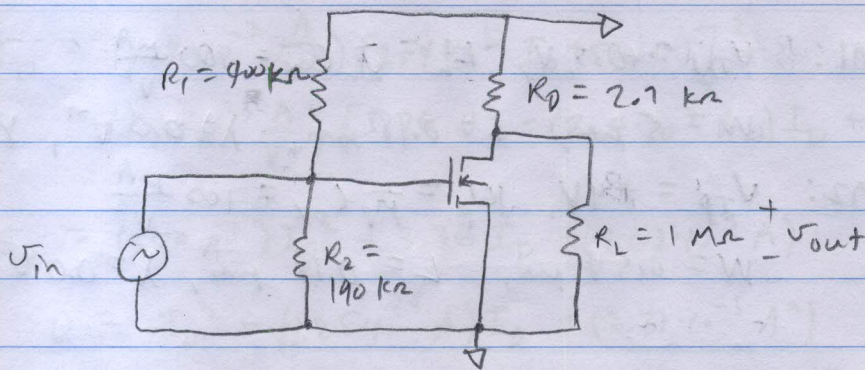

$$g_m = \frac{2I_D}{V_{GS} - V_{TN}} = \frac{2(2.368 \text{ mA})}{1.216 \text{ V}} = 3.895 \text{ mS}$$

$$r_o = \frac{1}{\lambda} + \frac{V_{DS}}{I_D} = \frac{10 \text{ V} + 1.422 \text{ V}}{2.368 \text{ mA}} = 4.823 \text{ k}\Omega$$

$$v_{gs} = v_{in}$$

$$v_{out} = -g_m v_{gs} (r_o \parallel R_D \parallel R_L) = -g_m v_{in} (r_o \parallel R_D \parallel R_L)$$

$$A_v = -g_m (r_o \parallel R_D \parallel R_L)$$

$$= -(3.895 \text{ mS})(1.728 \text{ k}\Omega)$$

$$A_v = -6.73 \text{ V/V}$$

g) to remain in small signal mode,  $v_{DS} \geq v_{GS} - V_{TN}$

$$v_{DS} - 6.73 v_{gs, \max} > v_{GS} + v_{gs, \max} - V_{TN}$$

$$v_{DS} - v_{GS} + V_{TN} > 7.73 v_{gs, \max}$$

$$27 \text{ mV} > v_{gs, \max}$$

$$\text{biggest } v_{out} \text{ DC swing}$$

$$= 6.73 v_{gs, \max}$$

$$= 179 \text{ mV}$$

2. M1:  $V_{TN} = +0.5 \text{ V}$ ,  $k'_n = \bar{\mu}_n C_{ox} = 100 \frac{\mu\text{A}}{\text{V}^2}$   
 $W = 5 \mu\text{m}$ ,  $L = 0.18 \mu\text{m}$ ,  $\lambda = 0.0 \text{ V}^{-1}$ ,  $\gamma = 0.0 \text{ V}^{1/2}$   
M2:  $V_{TP} = +4 \text{ V}$ ,  $k'_p = \bar{\mu}_p C_{ox} = 100 \frac{\mu\text{A}}{\text{V}^2}$   
 $W = 0.54 \mu\text{m}$ ,  $L = 0.18 \mu\text{m}$ ,  $\lambda = 0.0 \text{ V}^{-1}$ ,  $\gamma = 0.0 \text{ V}^{1/2}$

For a pMOSFET-like M2, the transistor is on if  $V_{GS} \leq -V_{TP}$ . Since the gate is tied to the source,  $V_{GS} = 0 \text{ V}$ , which will always be less than  $V_{TP} = +4 \text{ V}$ . M2 is on and acts as a current source with  $I_D$  still a function of M1 Q-pt.

a) DC equivalent circuit

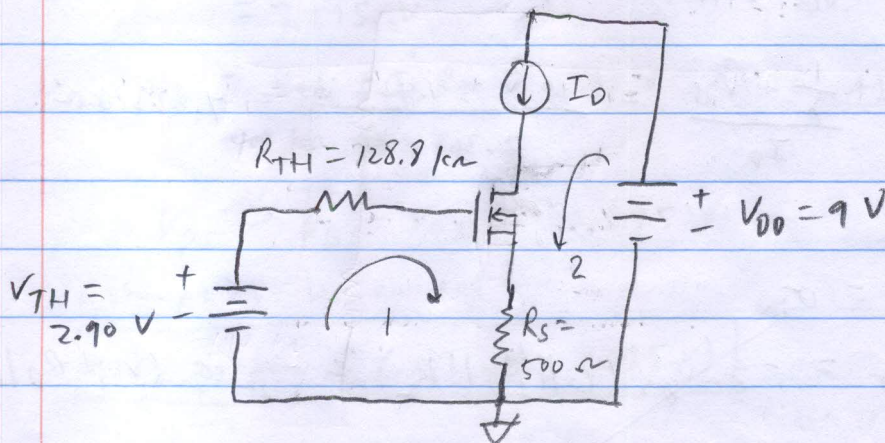

$V_{TH}$  and  $R_{TH}$  are same as problem 1

Loop 1:  $V_{TH} = V_{GS} + I_D R_S$

Loop 2:  $V_{DD} = V_{DS} + I_D R_S$

assuming saturation:  $I_D = \frac{k'_n}{2} \left(\frac{W}{L}\right) (V_{GS} - V_{TN})^2$

solving Loop 1 for  $V_{GS}$ :  $V_{GS} = V_{TH} - I_D R_S$

plug into  $I_D$ :  

$$I_D = \frac{k'_n}{2} \left(\frac{W}{L}\right) (V_{TH} - I_D R_S - V_{TN})^2$$



$$I_D = (1.4 \cdot 10^{-3} \frac{A}{V^2}) [2.4V - I_D (500\Omega)]^2$$

$$= (1.4 \cdot 10^{-3} \frac{A}{V^2}) [5.76 V^2 - (2.4 \cdot 10^3 V \cdot \Omega) I_D + (2.5 \cdot 10^5 \Omega^2) I_D^2]$$

$$I_D = (350 A^{-1}) I_D^2 - 3.36 I_D + (8.07 \cdot 10^{-3} A)$$

$$0 = I_D^2 - (1.25 \cdot 10^{-2} A) I_D + (2.31 \cdot 10^{-5} A^2)$$

$$I_D = \frac{+1.25 \cdot 10^{-2} A \pm \sqrt{(-1.25 \cdot 10^{-2} A)^2 - 4(2.31 \cdot 10^{-5} A^2)}}{2}$$

$$= +6.25 \text{ mA} \pm 4.0 \text{ mA}$$

test  $I_D = 2.25 \text{ mA}$  first:

$$V_{DS} = V_{DD} - I_D R_D = 9V - (2.25 \text{ mA})(500\Omega)$$

$$= 7.875V$$

$$V_{GS} = V_{TH} - I_D R_S = 2.90V - (2.25 \text{ mA})(500\Omega)$$

$$= 1.775V$$

$$V_{DS} > V_{GS} - V_{TN} = 1.275V$$

assumption is correct:

$$\boxed{\text{M1 Q-pt: } (2.25 \text{ mA}, 7.875V)}$$

$$g_{m1} = \frac{2I_D}{V_{GS} - V_{TN}} = \frac{2(2.25 \text{ mA})}{1.275V} = 3.53 \text{ mS}$$

$$r_{o1} = \frac{1/\lambda + V_{DS}}{I_D} = \frac{\infty + 7.875V}{2.25 \text{ mA}} = \infty \Omega$$

AC equivalent circuit

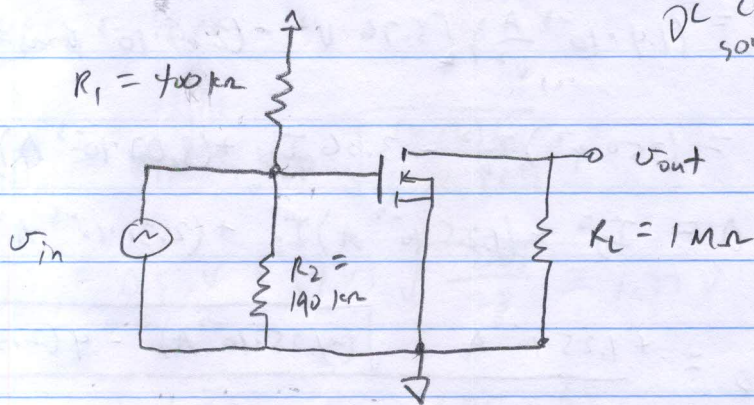

DC current source is an open circuit here

Small signal model

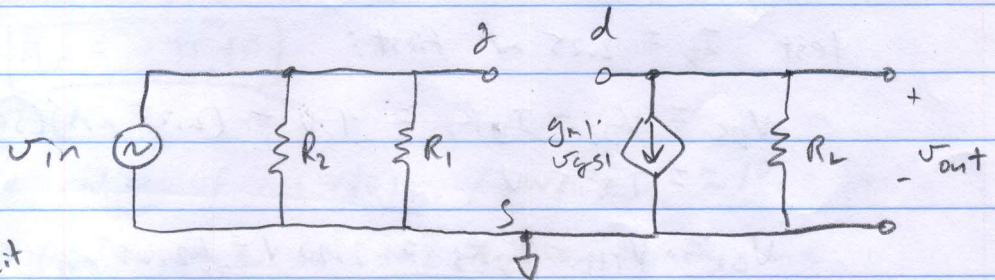

Recall:  $r_o = \infty \Omega$  = open circuit

$$v_{in} = v_{gs1}$$

$$v_{out} = -g_{m1} v_{gs1} R_L = -g_{m1} v_{in} R_L$$

$$A_v = \frac{v_{out}}{v_{in}} = -g_{m1} R_L = -(3.53 \text{ mS})(10^6 \Omega)$$

$$A_v = -3530 \text{ V/V}$$

b) We tie the bulk/body and source terminal together to eliminate a drifting of the expected  $V_{TP}$

$$c) \quad \left(\frac{W}{L}\right)_{M_2} = 2.81$$

$$\left(\frac{W}{L}\right)_{M_1} = 28$$

$$\begin{aligned} V_{GS1} &= V_{TN} + V_{TP} \sqrt{\frac{(W/L)_{M_2}}{(W/L)_{M_1}}} \\ &= 0.5 \text{ V} + (4 \text{ V}) \sqrt{\frac{2.81}{28}} = 1.77 \text{ V} \end{aligned}$$

$$g_{m1} = \frac{2I_D}{V_{GS1} - V_{TN}} = \frac{2(2.25 \text{ mA})}{1.27 \text{ V}} = 3.54 \text{ mS}$$

$$A_v = -g_{m1} R_L = (3.54 \text{ mS})(1 \text{ M}\Omega)$$

$$\boxed{A_v = -3540}$$

d) The ratio of  $(W/L)_{M_1} / (W/L)_{M_2} \approx 10$ . To take advantage of this higher gain, one should make  $W_{M_1} = 10W_{M_2}$ , and keep the gate lengths as low as possible.

3. a) Stealing Q-pt from DC analysis of 1(e),

$$V_{ps} = 1.422 \text{ V}$$

$$V_{gs} = 1.716 \text{ V}$$

$$I_D = 2.368 \text{ mA}$$

Stealing the transistor parameters from 1(f)

$$g_m = 3.895 \text{ mS}$$

$$r_o = 4.823 \text{ k}\Omega$$

ac equivalent circuit:

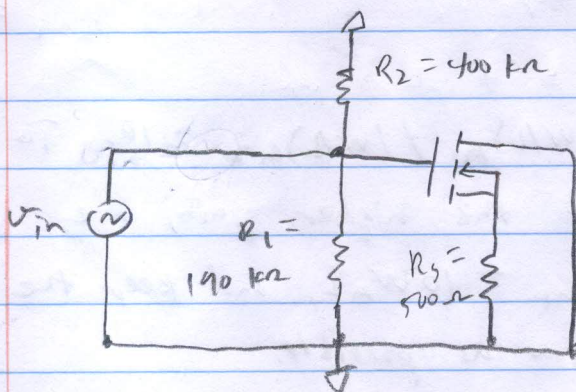

Note: common drain config

small signal model:

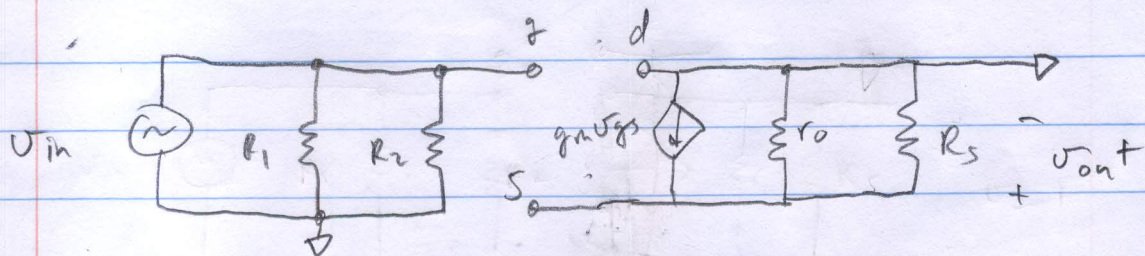

$$v_{out} = g_m v_{gs} (r_o \parallel R_s)$$

$$v_{in} = g_m v_{gs} (r_o \parallel R_s) + v_{gs} = v_{gs} [1 + g_m (r_o \parallel R_s)]$$

$$r_o \parallel R_s = 4.823 \text{ k}\Omega \parallel 500 \Omega = 453 \Omega$$

$$A_v = \frac{v_{out}}{v_{in}} = \frac{g_m (r_o \parallel R_s)}{1 + g_m (r_o \parallel R_s)} = \frac{(3.895 \cdot 10^{-3} \text{ S})(453 \Omega)}{1 + (3.895 \cdot 10^{-3} \text{ S})(453 \Omega)}$$

$$\boxed{A_v = 0.638 \text{ V/V}}$$

b) the phase of the circuit is  $0^\circ$  ( $v_{out}$  is in phase with  $v_{in}$ )

c)  $g_m \rightarrow \infty$

$$\boxed{A_v = 1}$$