

ECE 2030h, Intro. To Computer Eng., QUIZ 3

Quiz No. 3: Nov. 29, 2001  
 Prof. John A. Copeland  
 School of Electrical and Computer Engineering

RULES.

- i This quiz is closed book.
- ii. Non-programmable calculators may be used.
- iii Answer all questions and show all work to receive full credit.
- iv All questions have the same weight. (20 Points). All sub-questions within a question are weighted equally.
- v Please do not ask the proctors any questions during the exam about exam questions. Part of the test is understanding the question as written, without supplemental information. If you feel additional data is needed to solve the problem, make (and state) an assumption and then work the problem.

**Question 1 – Memory.**

A. Complete the table below. A “2M x 16” memory has 2M words of 16 bits.

Memory	Total Bits	# of addresses	# of address lines	# of data lines
1M x 4	$2^{22} = 4,194,304$	$2^{20} = 1,048,576$	20	4
1K by 8	$2^{13} = 8192$	$2^{10} = 1024$	10	8
64K x 32	$2^{21} = 2,097,152$	$2^{16} = 65,536$	16	32
4M x 16	$2^{26} = 67,108,864$	$2^{22} = 4,194,304$	22	16

B. Show how to connect these 1M x 16 chips to make a 2M by 16 memory.

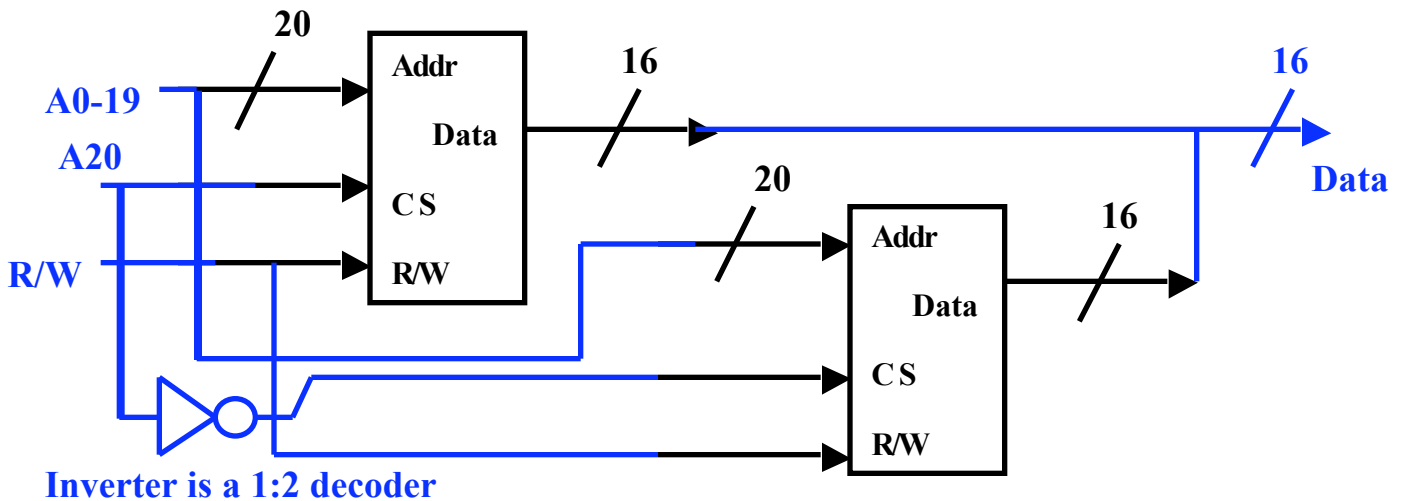

### Question 2 – Registers

Complete the timing diagram for the Register shown below showing the values at internal point A and output B.. Each “transparent latch” is “transparent when the clock signal, “phi 1” or “phi 2” is high. Assume the values at A and B are “0” at the start.

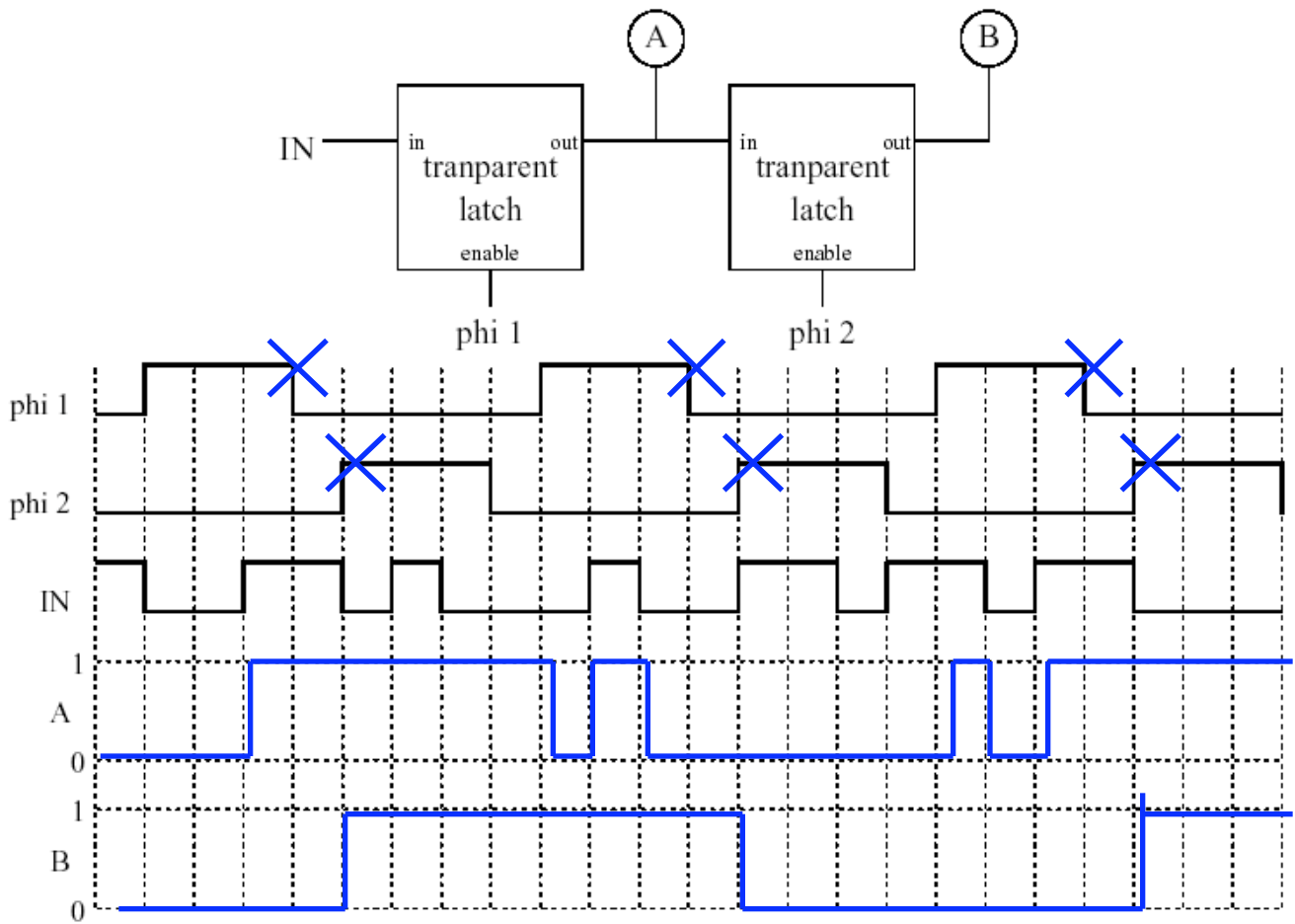

**Question 3 – CPU Control Lines**

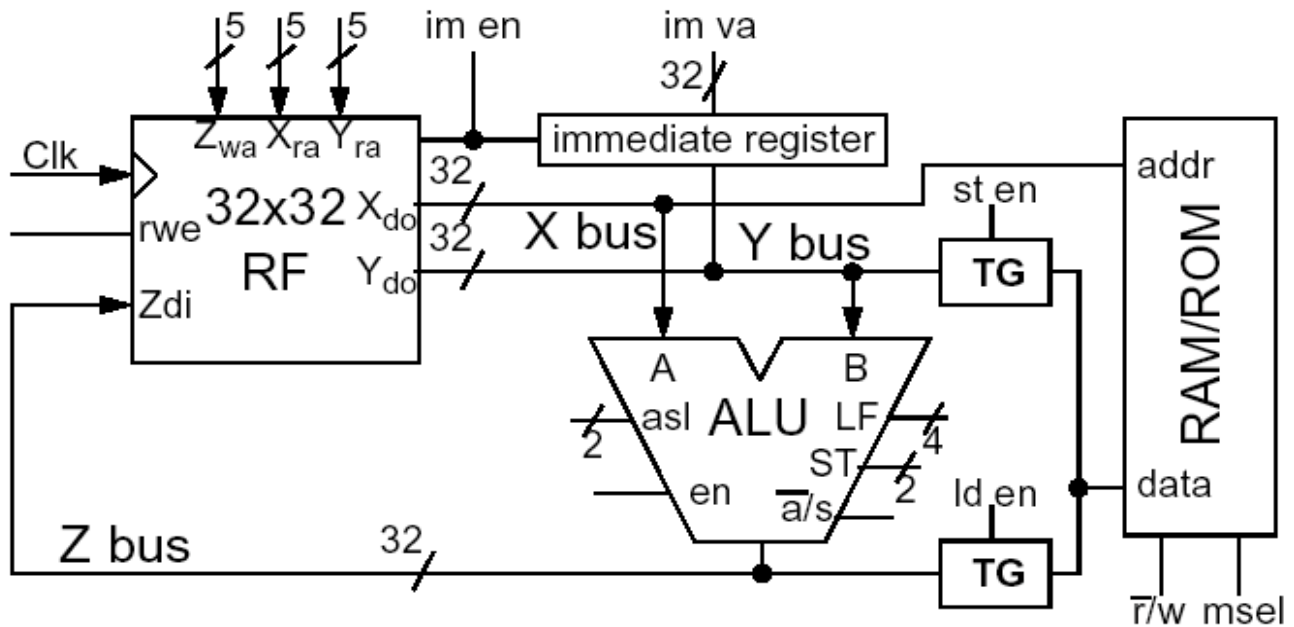

Show how the control lines are set to achieve the operations below. Assume msel = 1;

asl: 0=AU, 1=LU, 2=SU, 3 = invalid;      ST: 0=arithmetic, 1=logical, 2=rotate, 3 = invalid;  
 LF: 0=AND, 1=OR, 2=XOR, 3 = invalid;    a'/s: 0=add, 1= subtract      rwe: 1=write, 0= do not write

a. Add \$5 to \$9 and put the result in \$2      \$2 = \$5 + \$9

Mem r'/w	X	Y	Z	rwe	asl	a'/s	en	ld en	st en	im en	im va (Immediate Value)
0	5	9	2	1	0	0	1	0	0	0	X

b. Add \$5 to 54 and put the result in \$2      \$2 = \$5 + 54

Mem r'/w	X	Y	Z	rwe	asl	a'/s	en	ld en	st en	im en	im va (Immediate Value)
0	5	x	2	1	0	0	1	0	0	1	54

b. Add \$5 to the value in memory (address=\$9) and put the result in \$2      \$2 = \$5 + M[9]  
 (note: loading or storing data requires a separate CPU clock cycle). \$8=M[9] then \$2 = \$5 + \$8

Mem r'/w	X	Y	Z	rwe	asl	a'/s	en	ld en	st en	im en	im va (Immediate Value)
0	9	x	8	1	X	X	0	1	0	0	X
0	5	8	2	1	0	0	1	0	0	0	X

“8” may be any number except “5”, and the values of X any may be interchanged (except Y = “x”)