

Switch Design Problems

Switches-1: For each circuit below, write the logical function describing when the light is on.

a)

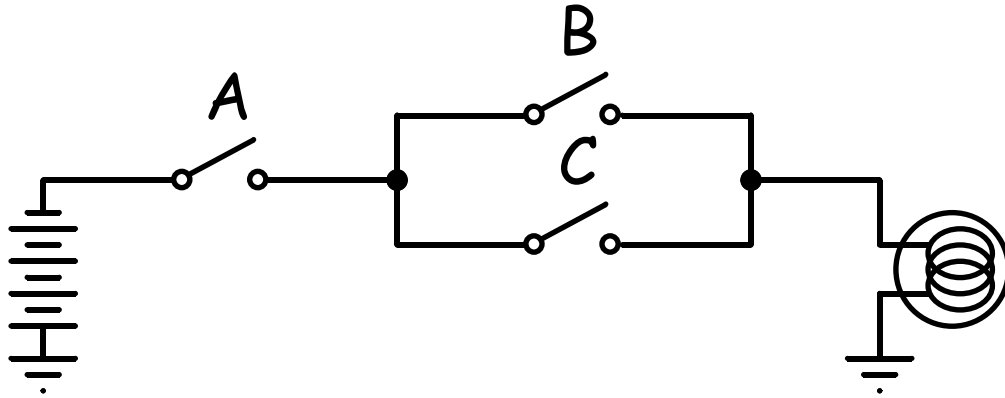

b)

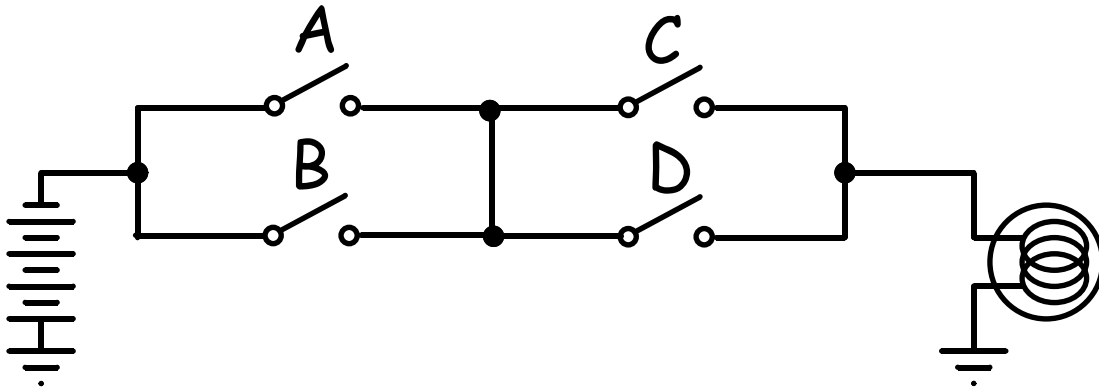

c)

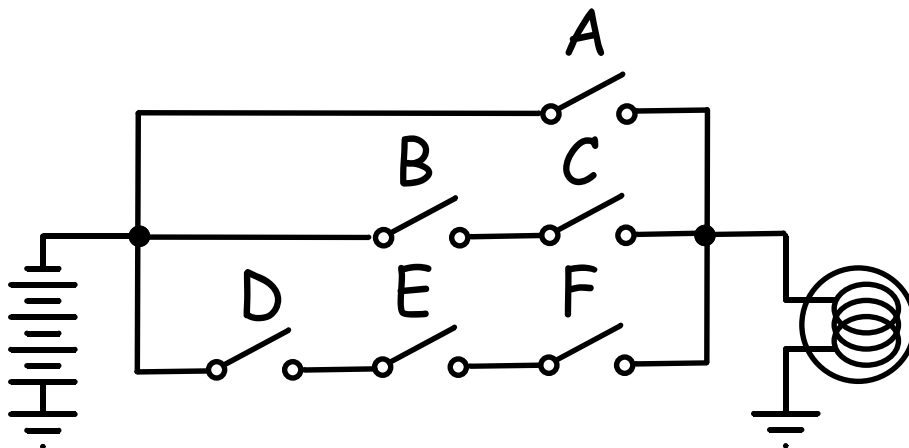

Switches-2: Design a switch level implementation of the following equations using NFETs and PFETs only. Assume that the complement of each signal is available.

- a) $f = \overline{A}$
- b) $f = A \cdot B$
- c) $f = A + B$
- d) $f = \overline{A \cdot B}$
- e) $f = \overline{A + B}$
- f) $f = \overline{A} \cdot B + A \cdot \overline{B}$

Switches-3: Design a switch level implementation of the following equations using NFETs and PFETs. Assume that the complement of each signal is available.

- a) $f = B \cdot (A + C)$
- b) $f = \overline{A} \cdot B + C$
- c) $f = A \cdot B + C \cdot D$
- d) $f = \overline{A} \cdot (\overline{B} + C \cdot D)$
- e) $f = \overline{A} \cdot (\overline{B} + \overline{C})$
- f) $f = (A + B) \cdot (B + C)$
- g) $f = A \cdot \overline{B} \cdot (\overline{C} + D)$
- h) $f = \overline{A} \cdot (\overline{B} \cdot C + \overline{D})$
- i) $f = A \cdot B + \overline{A} \cdot \overline{B} + \overline{B} \cdot C$
- j) $f = \overline{A} \cdot (B \cdot \overline{C} + \overline{D} \cdot E)$
- k) $f = (A + B + C) \cdot (D + E)$
- l) $f = \overline{\overline{A} \cdot B + C + \overline{D} \cdot E}$
- m) $f = \overline{A + \overline{B} \cdot D + C}$
- n) $f = (A + \overline{B} + E \cdot \overline{F}) \cdot (C \cdot D + G)$
- o) $f = \overline{(A + \overline{B} + C + D)} \cdot (E + F)$

Switches-4: Determine the Boolean expression and complete the truth table for each circuit below.

a)

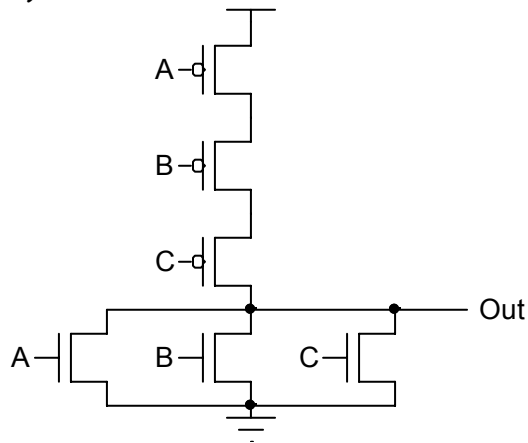

A	B	C	Out
0	0	0	
0	0	1	
0	1	0	
0	1	1	
1	0	0	
1	0	1	
1	1	0	
1	1	1	

b)

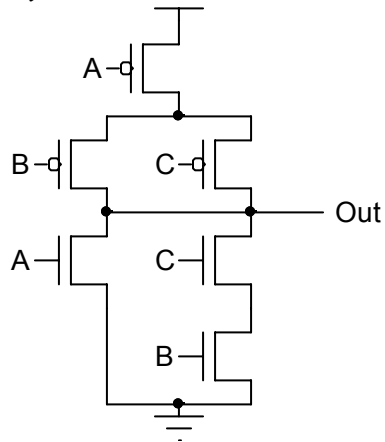

A	B	C	Out
0	0	0	
0	0	1	
0	1	0	
0	1	1	
1	0	0	
1	0	1	
1	1	0	
1	1	1	

c)

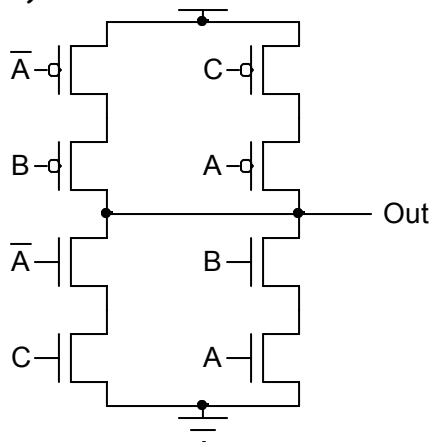

A	B	C	Out
0	0	0	
0	0	1	
0	1	0	
0	1	1	
1	0	0	
1	0	1	
1	1	0	
1	1	1	

d)

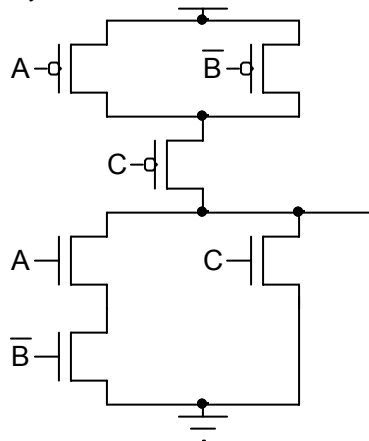

A	B	C	Out
0	0	0	
0	0	1	
0	1	0	
0	1	1	
1	0	0	
1	0	1	
1	1	0	
1	1	1	

e)

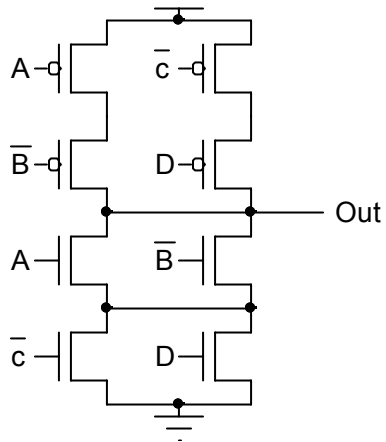

A	B	C	D	Out
0	0	0	0	
0	0	0	1	
0	0	1	0	
0	0	1	1	
0	1	0	0	
0	1	0	1	
0	1	1	0	
0	1	1	1	
1	0	0	0	
1	0	0	1	
1	0	1	0	
1	0	1	1	
1	1	0	0	
1	1	0	1	
1	1	1	0	
1	1	1	1	

f)

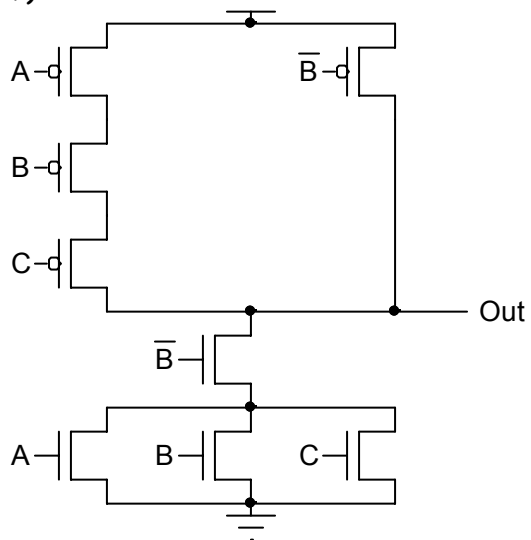

A	B	C	Out
0	0	0	
0	0	1	
0	1	0	
0	1	1	
1	0	0	
1	0	1	
1	1	0	
1	1	1	

g)

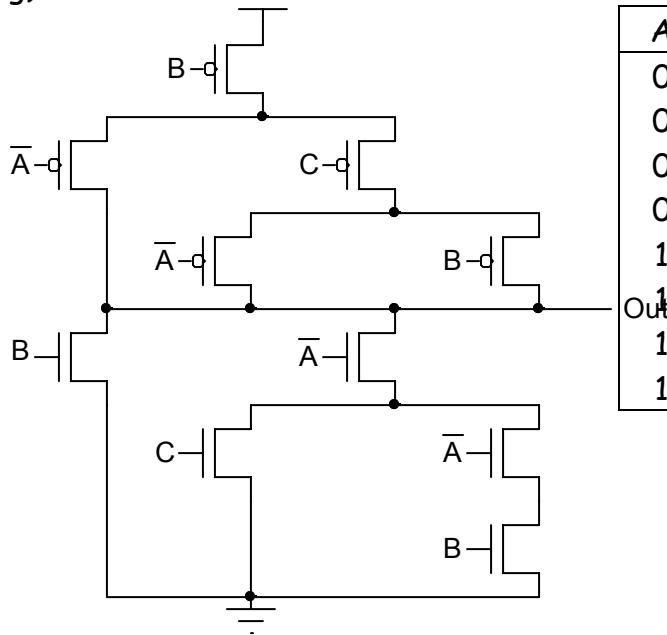

A	B	C	Out
0	0	0	
0	0	1	
0	1	0	
0	1	1	
1	0	0	
1	0	1	
1	1	0	
1	1	1	

h)

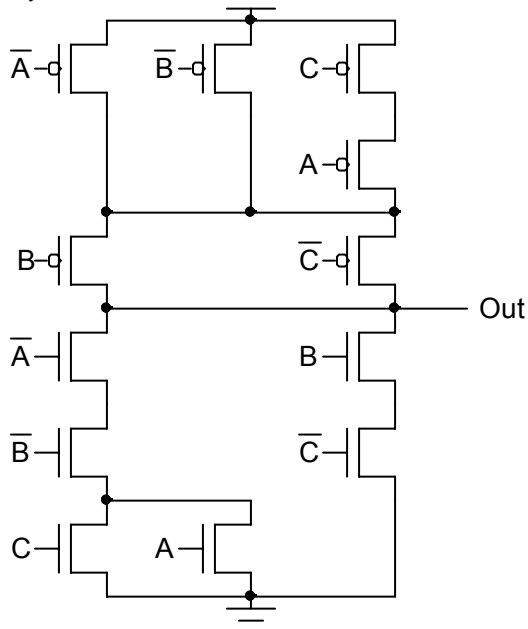

A	B	C	Out
0	0	0	
0	0	1	
0	1	0	
0	1	1	
1	0	0	
1	0	1	
1	1	0	
1	1	1	

i)

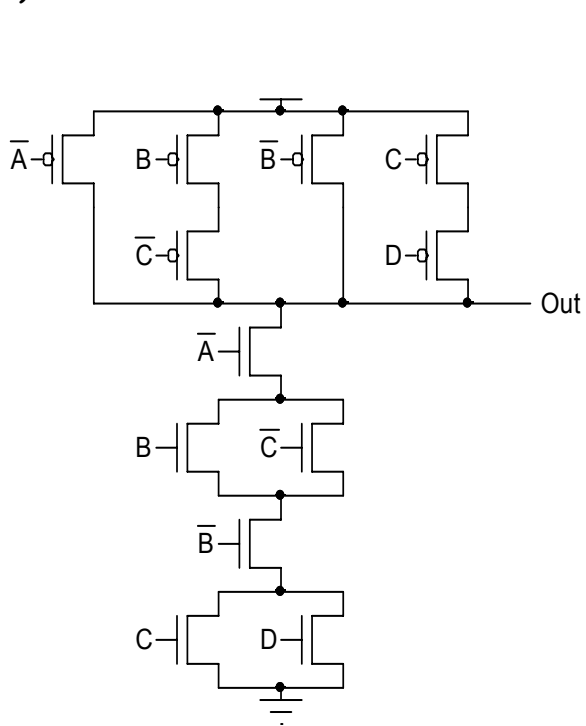

A	B	C	D	Out
0	0	0	0	
0	0	0	1	
0	0	1	0	
0	0	1	1	
0	1	0	0	
0	1	0	1	
0	1	1	0	
0	1	1	1	
1	0	0	0	
1	0	0	1	
1	0	1	0	
1	0	1	1	
1	1	0	0	
1	1	0	1	
1	1	1	0	
1	1	1	1	

j)

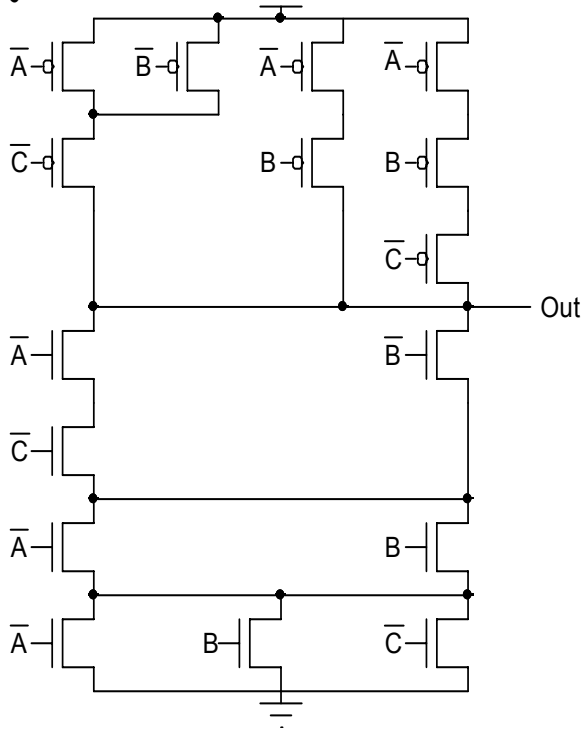

A	B	C	Out
0	0	0	
0	0	1	
0	1	0	
0	1	1	
1	0	0	
1	0	1	
1	1	0	
1	1	1	

k)

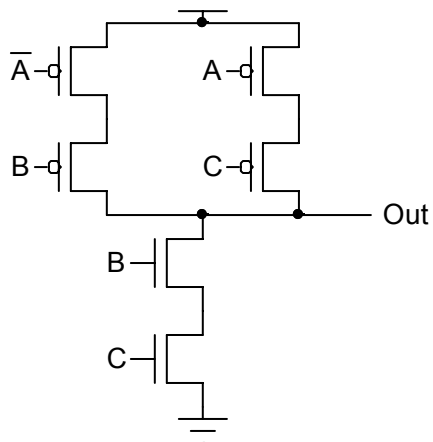

A	B	C	Out
0	0	0	
0	0	1	
0	1	0	
0	1	1	
1	0	0	
1	0	1	
1	1	0	
1	1	1	

l)

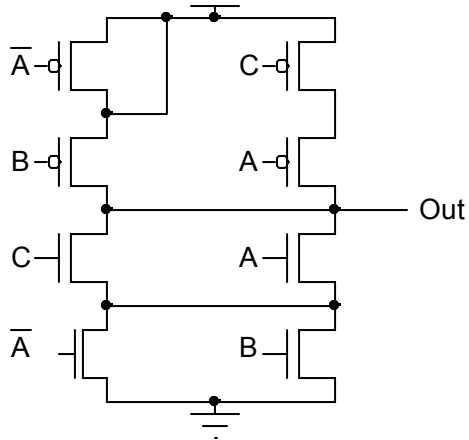

A	B	C	Out
0	0	0	
0	0	1	
0	1	0	
0	1	1	
1	0	0	
1	0	1	
1	1	0	
1	1	1	

m)

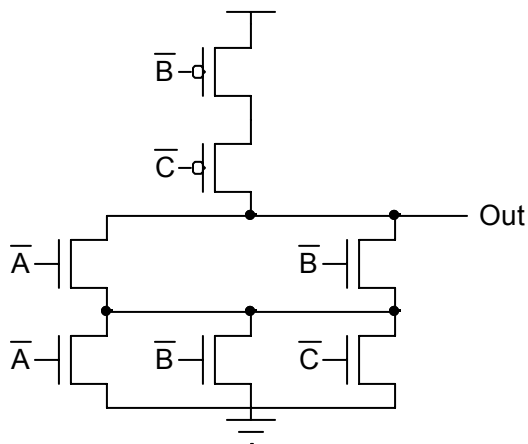

A	B	C	Out
0	0	0	
0	0	1	
0	1	0	
0	1	1	
1	0	0	
1	0	1	
1	1	0	
1	1	1	

Switches-5: Complete the following partial circuits, and then determine the equations representing the complete circuits.

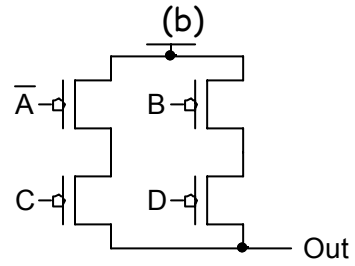
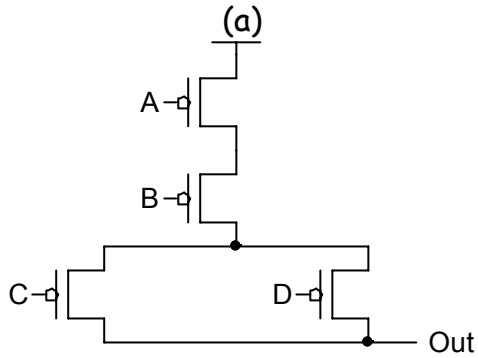

(c)

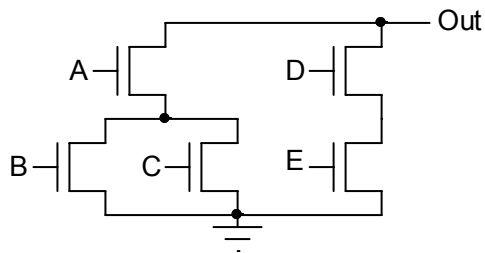

(d)

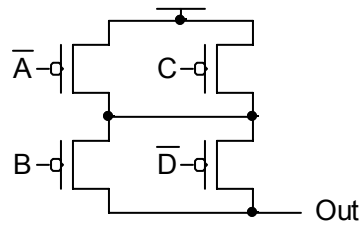

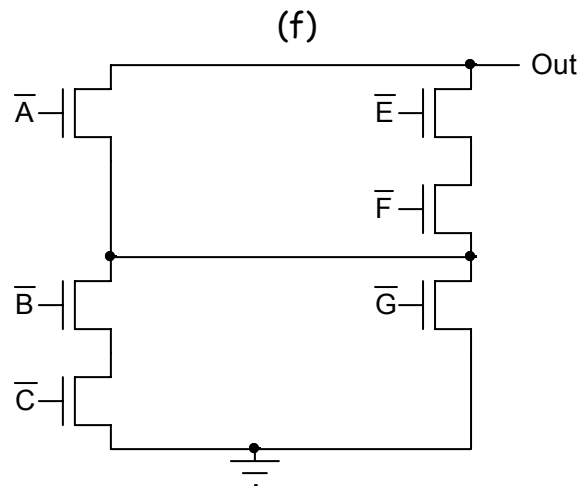
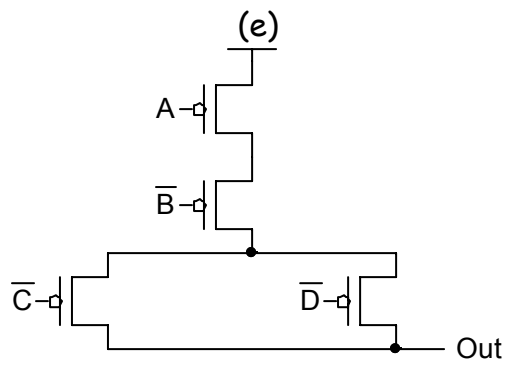

(g)

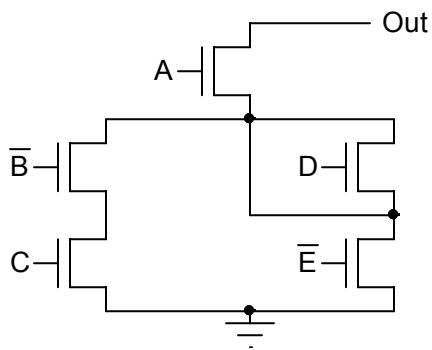

(h)

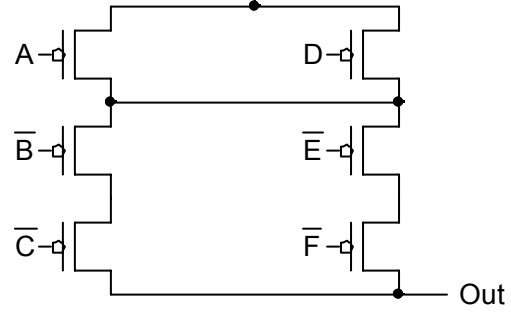

(i)

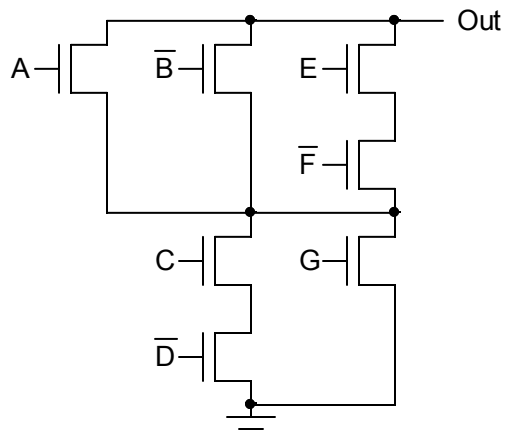

(j)

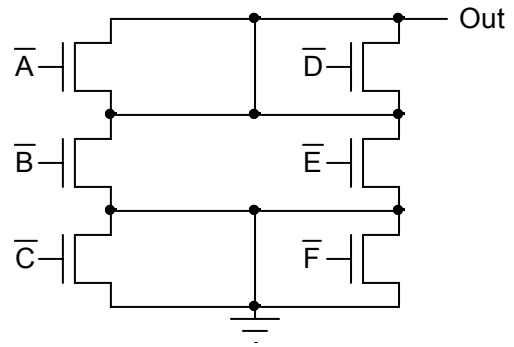

(k)

