

An Active Integrated Circuit Wireless Interference Cancellation Solution

Joy Laskar^{1,2}, Anand Raghavan^{1,2}, Chang-Ho Lee¹, Edward Gebara², Manos Tentzeris^{1,2}, Tony Stelliga²

¹Georgia Electronic Design Center, School of ECE, Georgia Institute of Technology, Atlanta, GA 30332

²Quellan Inc., 75 5th Street NW suite 210, Atlanta, GA 30308, USA

Abstract — This paper proposes a novel active interference cancellation system that allows simultaneous operation of multi-standard collocated radios. This method can be extended to other mutually interfering radio devices. A reference signal correlated to the original interferer is used to generate a cancellation signal by means of amplitude and phase alignment, and filtration. The filter employed emulates the coupling channel responsible for interference. An implementation of this procedure in 0.18 micrometer Si-CMOS IC technology is also presented. The circuits fabricated are tunable and are controlled externally by a closed loop adaptive process including an error minimization method. The cancellation system designed achieves 15–30 dB of interference suppression for different cases. A total power of 14 mW is dissipated by the CMOS ICs designed.

I. INTRODUCTION

The nature of growth in the wireless communications industry dictates that networking radios will be increasingly collocated in both frequency and space. This potentially places the multiple functionalities of wireless personal area networks (WPANs) and wireless local area networks (WLANs) at the users disposal while maintaining the benefits of spectral efficiency. The short range Bluetooth WPAN standard and the longer range Wi-Fi (IEEE 802.11b) that occupy the heavily used 2.4 GHz ISM band offer just such an example. However, despite the spread spectrum technologies employed in the above-mentioned radios and their complementary functions, their deployment in close proximity will necessarily lead to time-frequency collisions and interference.

Interference levels between Bluetooth and 802.11 WLAN radios for various situations have been quantified in the literature, in [1]. In [2], a probabilistic analysis of the interference environment is conducted and extended by simulation models of the Bluetooth and 802.11 Medium Access Control (MAC) and Physical Layer (PHY). The authors report a 25% packet loss while studying the performance of a Bluetooth module in the presence of WLAN interference. Similarly, the probability of 802.11 packet error in the presence of interference from a Bluetooth system is quantified in [3]. More recently, [4]-[5] offer simulations of these mutual interference phenomena with detailed models of the corresponding MAC and PHY layers.

As discussed in [5], various approaches may be adopted to suppress interference phenomena. Steps may be taken at the MAC or driver layer, but they have their limitations. For instance, software layer solutions will usually prevent simultaneous operation of the two radios. In this work, we propose a solution that is constituted in the PHY. Such a method is usually more exhaustive, allows simultaneous operation, and addresses the interference problem near the source.

In this paper we demonstrate the basic problem formulation, demonstration of active wireless cancellation and a reduction to working silicon integrated circuits for a particular application.

Problem Formulation

In order to estimate the magnitude of the problem, various sets of paired patch-antenna structures were fabricated on an FR-4 material. These were designed for operation at 2.4 GHz. As shown in a previous work by the authors [6], a significant amount of coupling between the antennas was observed. Distances ranging from $\lambda/2$ to $\lambda/10$ separated the antennas. Fig. 1 shows the input reflection coefficient for an antenna and the coupling between antennas. The coupling is most at a spacing of $\lambda/10$, as expected, and it varies in magnitude from –13 dB to –27 dB for different spacings.

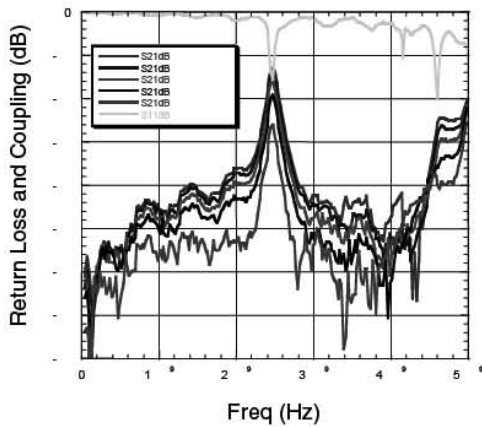

Fig. 1. Return loss and coupling for spaced patch antennas.

Proposed Solution

A Bluetooth aggressor is GFSK modulated with a bandwidth bit period product of 0.5. It is inherently narrow-band in the context of our problem with a symbol rate of 1 MS/s, occupying any of 79 RF channels in the 2400-2483.5 MHz band. The channels are defined by a pseudo-random hopping sequence, packet timing and access code, with a maximum hop rate of 1600 hops/s. The maximum transmit power is 20 dBm. An 802.11b signal uses complementary code keying (CCK), and occupies one of 3 non-overlapping 22 MHz channels in the same 2.4 GHz band. A maximum transmit power of 30 dBm is permitted.

In general, the cancellation technique employed may be represented as in Fig. 2.

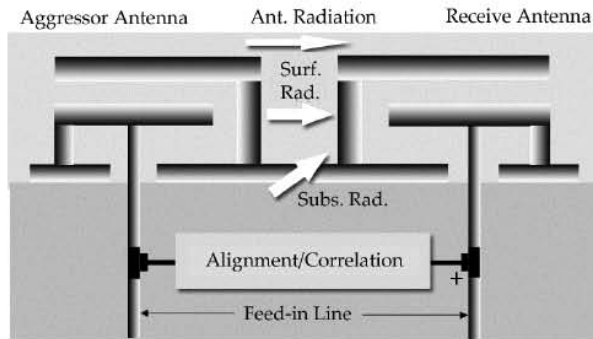

Fig. 2. Interference sources and cancellation mechanism.

Here, a downscaled replica of the transmitted signal is tapped off at the transmit end by means of a power-splitting device and passed through a cancellation unit. The generated cancellation signal is then combined with the received signal at a 180° phase differential. Control mechanisms are used to perform the appropriate amplitude and phase alignments. In some full-duplex systems, a loop cancellation method is used to generate narrow-band nulls at desired frequencies to achieve similar isolation. The cancellation chain achieves the task of correlating the tapped-off model of the interfering signal with the coupled signal at the 802.11 receiver. Adjusting the amplitude, and phase of the tapped-off signal to match the coupled signal performs the correlation.

TH3C-1

Since the carrier frequency is much higher than the data rate, the modulation of the transmitted signal does not complicate the problem and correlation can be achieved by amplitude, and phase adjustments alone.

Prototype Board

A Simplified block diagram of a prototype wireless canceller is shown in Fig. 3 was fabricated on FR-4 material, using several off-the-shelf components.

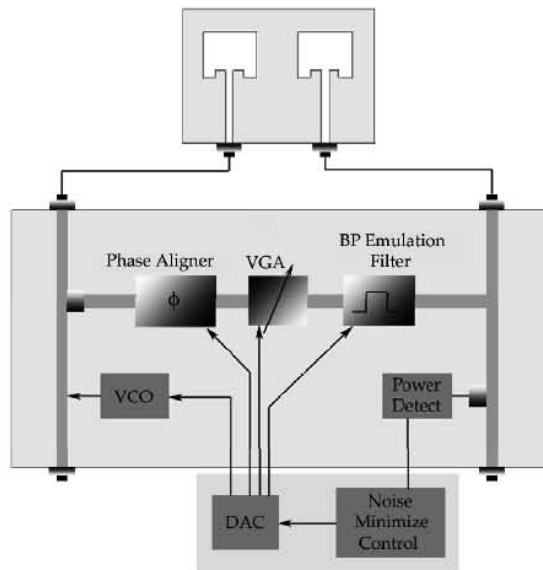

Fig. 3. Simplified schematic of interference canceller.

The coupling channel has a bandpass characteristic and is roughly constant for a given physical configuration of the antennas. Under mobile conditions, small changes in the magnitude of coupling are observed. The coupling channel was modeled throughout the 83.5 MHz pass band by means of a varactor diode and other discrete components.

IC Realization

The components in the correlation chain can be integrated on-chip if they are implemented in a standard IC process. With this as an objective, the amplitude and phase adjustment circuits were designed in a 0.18 μm CMOS technology. These designs were achieved by a voltage controlled Gilbert cell-based VGA and a 180° range analog active phase rotator. These circuits operate from a 1.8V supply and were capable of accepting a few hundred mV of input swing. In Figure 4, we show examples of the IC implementation (more detailed will be provided in the full paper) and the developed cancellation prototype. Measurements were performed on the canceller system to study its impact on the coupling characteristic. The emulation filter was adapted to the coupling channel in the presence of signals at 2.4 GHz. A plot showing the transmission parameters through the coupling channel before and after interference cancellation is presented in Fig. 4

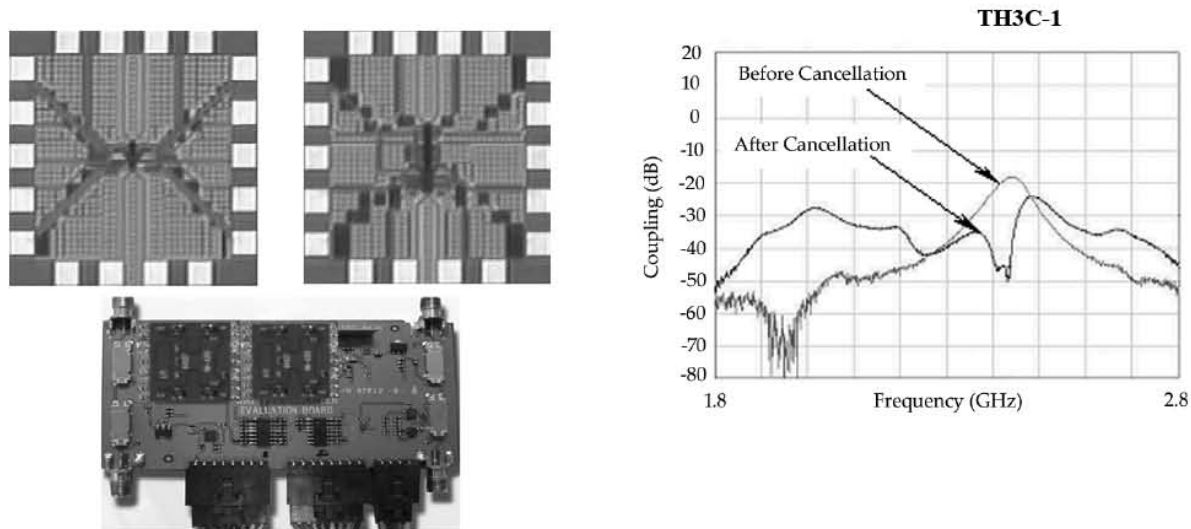

Fig. 4. Microphotographs of VGA and phase aligner on die, and canceller on board and coupling spectrum before and after interference cancellation.

CONCLUSIONS

An active cancellation technique enabling the coexistence of collocated radios has been analyzed. A canceller has been designed that provides significant interference mitigation at a low power cost. The general nature of the cancellation method proposed and implemented in this work suits its application to other radio environments provided the interfering radio systems are in close proximity of each other. Their mutual physical configuration also needs to be relatively static. These constraints are usually satisfied when the radios are situated on the same device. In the absence of the latter condition, or when the nature of correlation between the interferer and the reference signal is unknown, correlation must be established by means of an adaptive filter. Relieving an extremely high sensitivity receiver of interference is a promising alternative application. Such interference is found to occur from GSM transmitters that use power levels as high as 34 dBm in a frequency band 200 MHz away.

REFERENCES

- [1] A. Kamerman, "Coexistence between Bluetooth and IEEE 802.11 CCK: solutions to avoid mutual interference," *IEEE P802.11 Working Group Contribution, IEEE P802.11-00/162r0*, July 2000.
- [2] N. Golmie, "Impact of interference on the Bluetooth access control performance: preliminary results," *IEEE 802.15/00-322r0*, May 2000.
- [3] G. Ennis, "Impact of Bluetooth on 802.11 direct sequence," *IEEE 802.11-98/319*, September 1998.
- [4] N. Golmie, "Bluetooth and 802.11 interference: simulation model and system results," *IEEE 802.15-01/195r0*, April 2001.
- [5] J. Lansfor, A. Stephens, and R. Nevo, "Wi-Fi (802.11b) and Bluetooth: enabling coexistence," *IEEE Network*, vol. 15, issue 5, pp. 20-27, September-October 2001.
- [6] E. Gebara, M. M. Tentzeris, and J. Laskar, "An integrated CMOS interference canceller for MIMO systems," *34th European Microwave Conference 2004*, October 2004.