

Name: _____

Recitation Section: L _____

Student Number: _____

1. Check that your exam includes all 6 pages (cover, 6 problems). Additionally, there is a 2-sided formula sheet.
2. Read all instructions and problems carefully. Points will be deducted for failure to follow instructions.
3. Complete the information requested in the spaces above.
4. PRINT your name and student number in the spaces at the top of all remaining pages of this exam.
5. **Show ALL of your work on these pages.** The pages in this exam may be separated for grading; therefore, if you need extra space for a particular problem, write on the back of the page for that problem. The instructions for a specific question may limit the amount of space allowed for an answer. For all multiple choice questions, select the closest, or most appropriate, answer. Answers without supporting calculations may be discounted.
6. You are permitted one sheet (8 1/2 x 11, double-sided) of **handwritten** notes. Use of any other notes, books, or other resources is prohibited.
7. Calculators are permitted; however, you are not allowed to use the calculator memory to store notes, etc.
8. This exam lasts for 55 minutes. Point values are listed for each problem to assist you in best using your time.

_____	Problem 1.	(23 points possible)
_____	Problem 2.	(18 points possible)
_____	Problem 3.	(12 points possible)
_____	Problem 4.	(20 points possible)
_____	Problem 5	(12 points possible)
_____	Problem 6	(15 points possible)
_____	TOTAL.	(100 points possible)

Name: _____

Student #: _____

Problem 1. (23 points)

A company is considering two different types of 100 horsepower motors to operate a large assembly line. The motors are scheduled to be in service for 10 years, and both will deliver the same operational characteristics for the assembly line. At the end of the tenth year, the equipment will be returned to the manufacturer, with a predetermined salvage value. An interest rate of 8% is to be used. Determine the present value of the lifetime operating cost of each motor, including maintenance, electricity and salvage value, and then determine the cheapest motor. The purchase prices of both motors are equal, so that does not need to be considered. Show all calculations and factors. Factor calculations may be shown in space to right.

Motor #1

Maintenance \$3,000 per year, increases \$400 per year
Electricity: \$5,000 per year for years 1-5, \$3,000 per year for years 6-10
Salvage value of \$800 at end of tenth year

Motor #2

Maintenance \$2,000 per year.
Electricity: \$4,000 per year, increases 4% per year.
Salvage value of \$600 at end of tenth year

Motor #1

(10 pts.) Cost= _____

Motor #2

(10 pts.) Cost= _____

(3 pts.) Cheapest Motor # _____

Name: _____

Student #: _____

Problem 2. (18 points)

For this problem an interest rate of 6% is appropriate. The ac single phase motor operates at a rated line voltage of 200 volts RMS, and has an input power of 40 KW, a power factor of .8 lagging and an efficiency of 80%. The purchase cost of the motor is \$30,000.

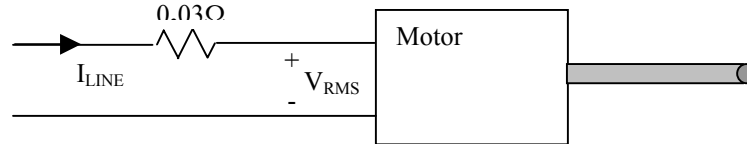

- A. (6 points) Determine the cost of power for one year for the motor, assuming that it operates 300 days per year, 8 hours per day, and at a cost of power of \$.05 per KW-hr.

Cost = _____

- B. (6 points) Determine the value of the power dissipated in the line resistance for one year, assuming the same rate.

New Line Current = _____

- C. (6 points) It is proposed that the purchase price of the motor be paid over 10 years with payments every 4 months. Assuming that the 6% is a nominal interest rate, determine the amount of each payment

Amount of each payment = _____

Problem 3. (12 points)

Answer the following multiple choice questions by circling the letter in front of the most appropriate response.

- A. The project completion time for a PERT Chart is assumed to be a normally distributed random variable. This assumption is most closely related to the concept that
- (a) each activity is assumed to have both a shortest and a longest time for completion.
 - (b) the individual activity times are uncorrelated random variables, and the central limit theorem applies to the sum.
 - (c) the float is zero along a critical path.
 - (d) the earliest and latest starts are uncorrelated random variables.
 - (e) the critical path is the longest path from start to finish.
- B. A utility company sometimes adjusts the cost of power if a purchaser adjusts the load power factor because
- (a) The load power factor needs to match that of the line.
 - (b) Line losses can be reduced.
 - (c) It is desirable to have a large line current.
 - (d) A highly efficient motor is expensive to operate.
- C. The technical purpose of the development of a family of microprocessors by the multi-company alliance discussed in Recitation #2 was
- (a) the development of increasingly cheaper machines over time;
 - (b) the development of a prototype for an ultra-high performance supercomputer;
 - (c) the development of progressively high performance machines;
 - (d) The development of a totally recyclable desk-top computer.
- D. A batch of 20,000 elastic bands is produced with a mean thermal characteristic of 1,200 (arbitrary units) and a standard deviation of 400. How many of the bands have a thermal characteristic greater than 600?
- (a) 1,336
 - (b) 4,550
 - (c) 8,664
 - (d) 13,336
 - (e) 18,664

Problem 4. (20 points)

- A. (8 points) Determine the critical path, and its duration, for the following CPM chart. State the path in terms of activity letters in order from start to finish. Example: AEKM, duration=12

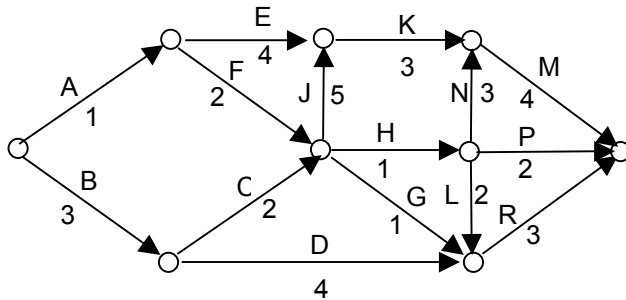

Path and Duration _____

- B. (6 points) Determine the float for

(i) Activity H

Float H = _____

(ii) Activity K

Float K = _____

- C. (6 points) Assume that, for a slightly different diagram, a PERT chart, the project duration is 18 months and the standard deviation is 6 months. Determine the probability that the project will require greater than 15 months to complete.

Probability = _____

Name: _____

Student #: _____

Problem 5. (12 points)

For each of the sentence pairs below, select the sentence (#1 or #2) that is **incorrect**, by either word usage, spelling, or content (do not consider punctuation).

- A. #1 In the design process, one of the major advantages of partitioning is that, since there are more divisions, it is easier to obtain a globally optimized design.
- #2 In the design process, one of the major disadvantages of partitioning is that, since there are more divisions, there are more interface specifications required.
- B. #1 There were less students registered for the afternoon laboratory section.
- #2 Fewer than six hours had passed before it was time to depart.
- C. #1 The university was unable to settle the dispute between the three students.
- #2 The university was unable to effect a solution to the budgetary difficulty.
- D. #1 A fundamental problem with design for recyclability is that technology changes may render the modular components obsolete.
- #2 A fundamental problem with design for recyclability is the expense in separating mixed materials.

Problem 6. (15 points)

For each of the following statements, circle either TRUE or FALSE.

- A. For the accelerated cost recovery method of depreciation, the first year expense charged to depreciation is usually less than it would be under the straight line method, assuming that the actual life is the same as the property life used in the accelerated method. **TRUE FALSE**
- B. The effective rate of interest is usually less than the nominal rate for a given calculation. **TRUE FALSE**
- C. To construct a simulation, the design must be mathematically modelled. **TRUE FALSE**
- D. The book value of a piece of capital equipment is always greater than the market value. **TRUE FALSE**
- E. For a series of 20 annual payments such that each payment is 6% greater than the previous payment, then the tenth payment is greater than twice the first payment of the series. **TRUE FALSE**