

ECE4893A/CS4803MPG:
**MULTICORE AND GPU
 PROGRAMMING
 FOR VIDEO GAMES**

GPUs – Under the Hood



Prof. Aaron Lanterman
 School of Electrical and Computer Engineering
 Georgia Institute of Technology

Georgia Institute of Technology

Bandwidth – Gravity of Modern Computer Systems

- The bandwidth between key components ultimately dictates system performance
 - Especially true for massively parallel systems processing massive amount of data
 - Tricks like buffering, reordering, caching can temporarily defy the rules in some cases
 - Ultimately, the performance goes falls back to what the “speeds and feeds” dictate

Slide by David Kirk/NVIDIA and Wen-mei. W. Hwu, 2007,
 from UIUC ECE498 Lecture 6, Fall 2007; used with permission
 See courses.ece.uiuc.edu/ece498/al1

Georgia Institute of Technology

Interface “feeds and speeds”

- AGP: Advanced Graphics Port – an interface between the computer core logic and the graphics processor
 - AGP 1x: 266 MB/sec – twice as fast as PCI
 - AGP 2x: 533 MB/sec
 - AGP 4x: 1 GB/sec → AGP 8x: 2 GB/sec
 - 256 MB/sec readback from graphics to system
- PCI-E: PCI Express – a faster interface between the computer core logic and the graphics processor
 - PCI-E 1.0: 4 GB/sec each way → 8 GB/sec total
 - PCI-E 2.0: 8 GB/sec each way → 16 GB/sec total

Slide by David Kirk/NVIDIA and Wen-mei. W. Hwu, 2007,
 from UIUC ECE498 Lecture 5, Fall 2007; used with permission
 See courses.ece.uiuc.edu/ece498/al1

Georgia Institute of Technology

3D Buzzwords

- Fill Rate – how fast the GPU can generate pixels, often a strong predictor for application frame rate
- Performance Metrics
 - Mtris/sec - Triangle Rate
 - Mverts/sec - Vertex Rate
 - Mpixels/sec - Pixel Fill (Write) Rate
 - Mtexels/sec - Texture Fill (Read) Rate
 - Msamples/sec - Antialiasing Fill (Write) Rate

Slide by David Kirk/NVIDIA and Wen-mei. W. Hwu, 2007,
 from UIUC ECE498 Lecture 5, Fall 2007; used with permission
 See courses.ece.uiuc.edu/ece498/al1

Georgia Institute of Technology

Adding Programmability to the Graphics Pipeline

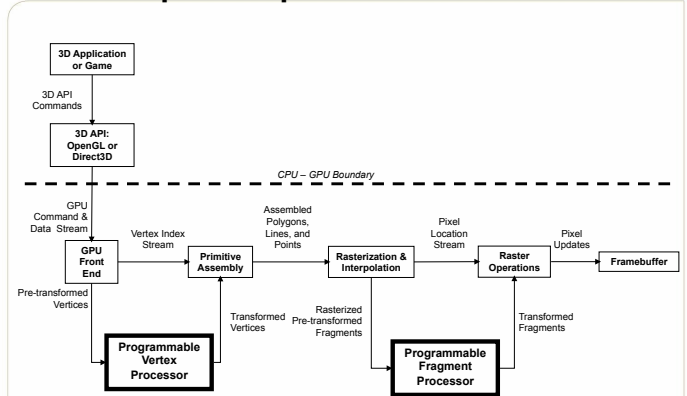

Slide by David Kirk/NVIDIA and Wen-mei. W. Hwu, 2007, from UIUC ECE498 Lecture 5, Fall 2007; used with permission See courses.ece.uiuc.edu/ece498/a1



Specialized Instructions (GeForce 6)

- Dot products
- Exponential instructions:
 - EXP, EXPP, LOG, LOGP
 - LIT (Blinn specular lighting model calculation!)
- Reciprocal instructions:
 - RCP (reciprocal)
 - RSQ (reciprocal square root!)
- Trigonometric functions
 - SIN, COS
- Swizzling (swapping xyzw), write masking (only some xyzw get assigned), and negation is “free”

From GPU Gems 2, p. 484



Easy cross products and normalization

```

Vector Cross Product
# | i   j   k | into R2.
# | R0.x R0.y R0.z |
# | R1.x R1.y R1.z |
MUL R2, R0.zxyw, R1.yzxw; // swizzle
MAD R2, R0.yzxw, R1.zxyw, -R2; // negation
    
```

```

Vector Normalize
# R1 = (nx,ny,nz)
#
# R0.xyz = normalize(R1)
# R0.w = 1/sqrt(nx*nx + ny*ny + nz*nz)
DP3 R0.w, R1, R1;
RSQ R0.w, R0.w; // write-mask
MUL R0.xyz, R1, R0.w; // promotion
    
```

CS448 Lecture 12

Kurt Akeley, Pat Hanrahan, Fall 2001

From Stanford CS448A: Real-Time Graphics Architectures See graphics.stanford.edu/courses/cs448a-01-fall



Blinn lighting in one instruction

```

LIT d, s

s.x = N • L
s.y = N • H
s.z = s (-128<m<128)

d.x = 1.0
d.y = CLAMP(N • L, 0, 1)
d.z = CLAMP(N • H, 0, 1)s
d.w = 1.0
    
```

From Stanford CS448A: Real-Time Graphics Architectures See graphics.stanford.edu/courses/cs448a-01-fall



Simple graphics pipeline

```

# c[0-3] = Mat; c[4-7] = Mat^(-T)
# c[32] = L; c[33] = H
# c[35].x = Md * Ld; c[35].y = Ma * La
# c[36] = Ms; c[38].x = s
DP4 o[HPOS].x, c[0], v[OPOS]; # Transform position.
DP4 o[HPOS].y, c[1], v[OPOS];
DP4 o[HPOS].z, c[2], v[OPOS];
DP4 o[HPOS].w, c[3], v[OPOS];
DP3 R0.x, c[4], v[NRML]; # Transform normal.
DP3 R0.y, c[5], v[NRML];
DP3 R0.z, c[6], v[NRML];
DP3 R1.x, c[32], R0; # R1.x = L DOT N
DP3 R1.y, c[33], R0; # R1.y = H DOT N
MOV R1.w, c[38].x; # R1.w = s
LIT R2, R1; # Compute lighting
MAD R3, c[35].x, R2.y, c[35].y; # diffuse + ambient
MAD o[COL0].xyz, c[36], R2.z, R3; # + specular
END
    
```

From Stanford CS448A: Real-Time Graphics Architectures
 See graphics.stanford.edu/courses/cs448a-01-fall



The GeForce Graphics Pipeline

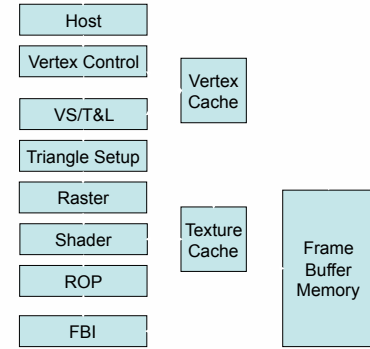

Slide by David Kirk/NVIDIA and Wen-mei. W. Hwu, 2007,
 from UIUC ECE498 Lecture 5, Fall 2007; used with permission
 See courses.ece.uiuc.edu/ece498/af1



Vertex Cache

- Temporary store for vertices, used to gain higher efficiency
- Re-using vertices between primitives saves AGP/PCI-E bus bandwidth
- Re-using vertices between primitives saves GPU computational resources
- A vertex cache attempts to exploit “commonality” between triangles to generate vertex reuse
- Unfortunately, many applications do not use efficient triangular ordering

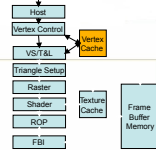

Slide by David Kirk/NVIDIA and Wen-mei. W. Hwu, 2007,
 from UIUC ECE498 Lecture 5, Fall 2007; used with permission
 See courses.ece.uiuc.edu/ece498/af1



Texture Cache

- Stores temporarily local texel values to reduce bandwidth requirements
- Due to nature of texture filtering high degrees of efficiency are possible
- Efficient texture caches can achieve 75% or better hit rates
- Reduces texture (memory) bandwidth by a factor of four for bilinear filtering

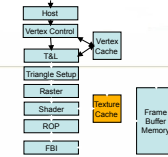

Slide by David Kirk/NVIDIA and Wen-mei. W. Hwu, 2007,
 from UIUC ECE498 Lecture 5, Fall 2007; used with permission
 See courses.ece.uiuc.edu/ece498/af1



Built-in Texture Filtering (GeForce 6)

- Pixel texturing
 - Hardware supports 2D, 3D, and cube map
 - Non power-of-2 textures OK
 - Hardware handles addressing and interpolation for you
 - Bilinear, trilinear (3D or mipmap), anisotropic

- Vertex texturing
 - Vertex processors can access texture memory too
 - Only nearest-neighbor filtering supported in G60 hardware

ROP (from Raster Operations)

- C-ROP performs frame buffer blending
 - Combinations of colors and transparency
 - Antialiasing
 - Read/Modify/Write the Color Buffer
- Z-ROP performs the Z operations
 - Determine the visible pixels
 - Discard the occluded pixels
 - Read/Modify/Write the Z-Buffer
- ROP on GeForce also performs
 - "Coalescing" of transactions
 - Z-Buffer compression/decompression

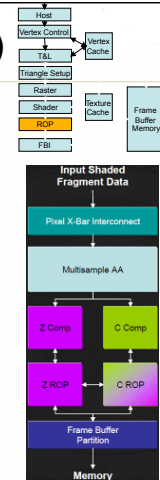

The Frame Buffer

- The primary determinant of graphics performance other than the GPU
- The most expensive component of a graphics product other than the GPU
- Memory bandwidth is the key
- Frame buffer size also determines
 - Local texture storage
 - Maximum resolutions
 - Antialiasing resolution limits

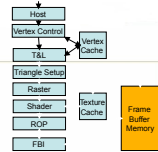

Frame Buffer Interface (FBI)

- Manages reading from and writing to frame buffer
- Perhaps the most performance-critical component of a GPU
- GeForce's FBI is a crossbar
- Independent memory controllers for 4+ independent memory banks for more efficient access to frame buffer

