

ECE3050 – Assignment 13

1. The figure shows a current mirror. The transistors are identical.

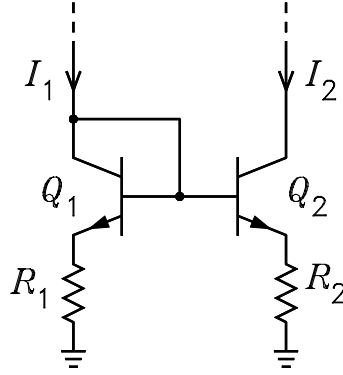

- (a) If the base currents and the Early effect can be neglected, use the equations

$$I_1 = I_S e^{V_{BE1}/V_T} \quad I_2 = I_S e^{V_{BE2}/V_T} \quad V_{BE1} + I_1 R_1 = V_{BE2} + I_2 R_2$$

to show that

$$I_1 \exp\left(\frac{I_1 R_1}{V_T}\right) = I_2 \exp\left(\frac{I_2 R_2}{V_T}\right)$$

- (b) If $I_1 = 1 \text{ mA}$, $R_1 = 1.2 \text{ k}\Omega$, and $V_T = 25 \text{ mV}$, solve for R_2 for $I_2 = 20 \mu\text{A}$. Answer: $R_2 = 64.89 \text{ k}\Omega$.

2. The figure shows a current mirror.

- (a) If the transistors are identical and the Early effect can be neglected, label all currents in the unlabeled branches in terms of I_O .
- (b) Write a KCL equation at the collector of Q_1 and use it to solve for I_O .
- (c) What is the minimum β for $I_O \geq 0.99 I_{REF}$? Answer: $\beta \geq 198$.
- (d) What is the small-signal output resistance r_{out} ? Answer: $r_{out} = r_{o2}$.
- (e) Explain how the Early effect can cause I_O to be greater than I_{REF} .

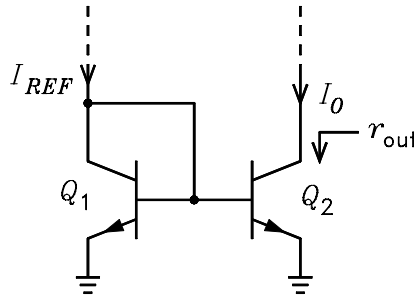

3. The figure shows a current mirror with base current compensation.

- (a) If the transistors are identical and the Early effect can be neglected, label all currents in the unlabeled branches in terms of I_O .
- (b) Write a KCL equation at the collector of Q_1 and use it to show that I_O is given by

$$I_O = \frac{I_{REF}}{1 + \frac{2}{\beta(1 + \beta)}}$$

- (c) What is the minimum β for $I_O \geq 0.99I_{REF}$? Answer: $\beta \geq 13.58$.
 (d) What is the small-signal output resistance r_{out} ? Answer: $r_{out} = r_{o2}$.
 (e) Explain how the Early effect can cause I_O to be greater than I_{REF} .

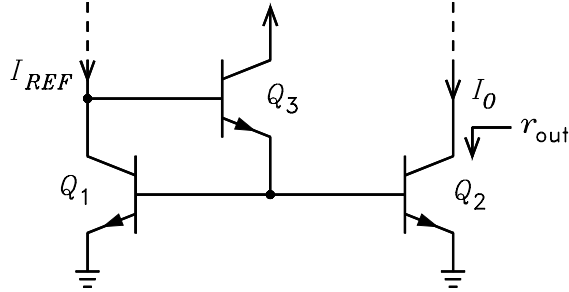

4. The figure shows a Wilson current mirror
 (a) If the transistors are identical and the Early effect can be neglected, label all currents in the unlabeled branches in terms of I_O . Hint, express I_{E3} in terms of I_O and use the results of problem 2 to show that I_{C1} is given by n terms of I_{E3}

$$I_{C1} = \frac{I_O/\alpha}{1 + \frac{2}{\beta}}$$

- (b) Write a KCL equation at the collector of Q_1 and use it to show that I_O is given by

$$I_O = \frac{I_{REF}}{\frac{1}{\alpha} \frac{1}{1 + \frac{2}{\beta}} + \frac{1}{\beta}}$$

- (c) What is the minimum β for $I_O \geq 0.99I_{REF}$? Answer: $\beta \geq 13.12$.
 (d) Explain how a positive feedback effect causes the small-signal output resistance to be greater than r_{o3} .

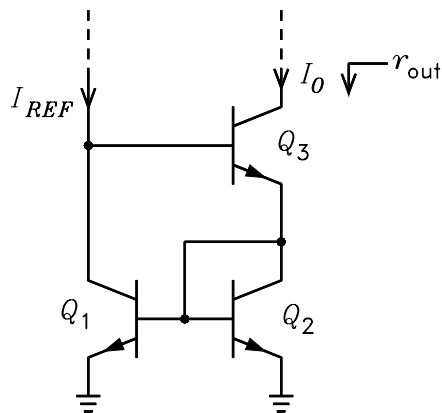

5. The figure shows a transconductance op amp. (a) It is desired to obtain an output current given by $i_o = 0.02(v_{i1} - v_{i2})$. If $V_T = 0.025$ V, what must be the value of I_{ABC} ? Answer: $I_{ABC} = 1$ mA.

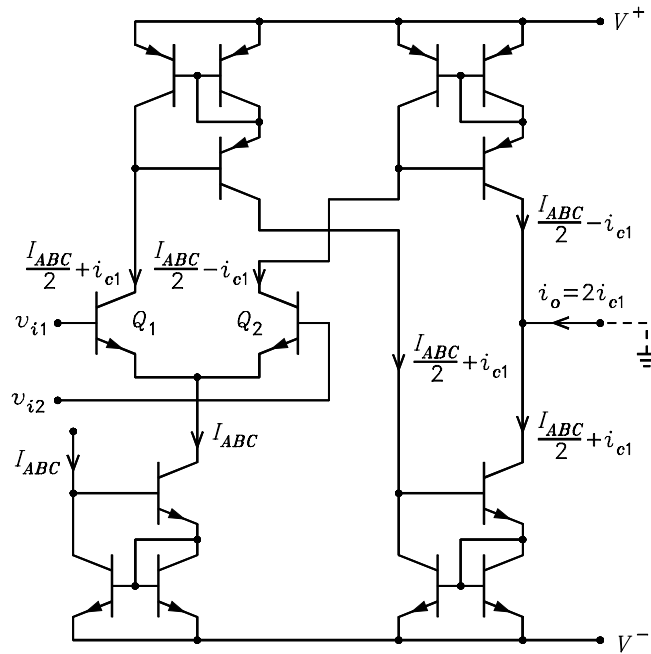

6. The transconductance op amp of problem 5 is to be connected to a current-to-voltage converter as shown below.

(a) The maximum peak value of v_i is ± 5 V. Specify the values of R_1 and R_2 which will prevent the voltage applied to the + terminal of the op amp from exceeding 40 mV. The source resistance seen looking out of the + terminal is to be $100\ \Omega$. Answers: $R_1 = 12.5\ \text{k}\Omega$ and $R_2 = 101\ \Omega$.

(b) For I_{ABC} given by the value found in problem 5, calculate the value of R_F for $v_o = 8$ V when $v_i = 5$ V. Assume C_F is an open circuit. Answer: $R_F = 10\ \text{k}\Omega$.

(c) Sketch and label the waveform for v_o if $v_i(t) = 5 \sin(20000\pi t)$ and $I_{ABC} = 1 \times 10^{-3} [1 + 0.5 \sin(2000\pi t)]$. The waveform can easily be displayed with Mathcad, Matlab, or Excel.

