

The BJT

Notation

The notations used here for voltages and currents correspond to the following conventions: Dc bias values are indicated by an upper case letter with upper case subscripts, e.g. V_{DS} , I_C . Instantaneous values of small-signal variables are indicated by a lower-case letter with lower-case subscripts, e.g. v_s , i_c . Total values are indicated by a lower-case letter with upper-case subscripts, e.g. v_{BE} , i_D . Circuit symbols for independent sources are circular and symbols for controlled sources have a diamond shape. Voltage sources have a \pm sign within the symbol and current sources have an arrow.

Device Equations

Figure 1 shows the circuit symbols for the npn and pnp BJTs. In the active mode, the collector-base junction is reverse biased and the base-emitter junction is forward biased. For the npn device, the active-mode collector and base currents are given by

$$i_C = I_S \exp\left(\frac{v_{BE}}{V_T}\right) \quad i_B = \frac{i_C}{\beta} \quad (1)$$

where V_T is the thermal voltage, I_S is the saturation current, and β is the base-to-collector current gain. These are given by

$$V_T = \frac{kT}{q} = 0.025 \text{ V for } T = 290 \text{ K} = 25.86 \text{ mV for } T = 300 \text{ K} \quad (2)$$

$$I_S = I_{S0} \left(1 + \frac{v_{CE}}{V_A}\right) \quad (3)$$

$$\beta = \beta_0 \left(1 + \frac{v_{CE}}{V_A}\right) \quad (4)$$

where V_A is the Early voltage and I_{S0} and β_0 , respectively, are the zero bias values of I_S and β . Because $I_S/\beta = I_{S0}/\beta_0$, it follows that i_B is not a function of v_{CE} . The equations apply to the pnp device if the subscripts BE and CE are reversed.

The emitter-to-collector current gain α is defined as the ratio i_C/i_E . To solve for this, we can write

$$i_E = i_B + i_C = \left(\frac{1}{\beta} + 1\right) i_C = \frac{1 + \beta}{\beta} i_C \quad (5)$$

It follows that

$$\alpha = \frac{i_C}{i_E} = \frac{\beta}{1 + \beta} \quad \beta = \frac{i_C}{i_B} = \frac{\alpha}{1 - \alpha} \quad (6)$$

Thus the currents are related by the equations

$$i_C = \beta i_B = \alpha i_E \quad (7)$$

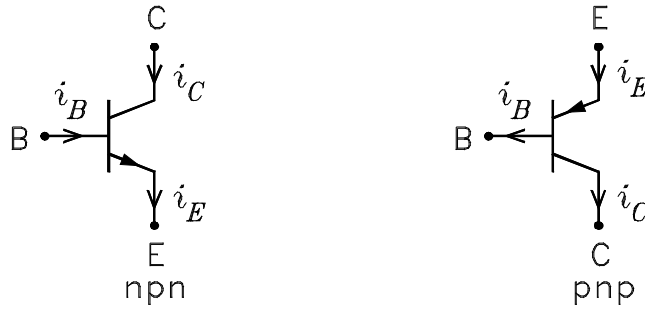

Figure 1: BJT circuit symbols.

Transfer Characteristics

The transfer characteristics are a plot of the collector current i_C as a function of the base-to-emitter voltage v_{BE} with the collector-to-emitter voltage v_{CE} held constant. From Eqs. 1 and 3, we can write

$$i_C = I_{S0} \left(1 + \frac{v_{CE}}{V_A} \right) \exp \left(\frac{v_{BE}}{V_T} \right) \quad (8)$$

It follows that i_C varies exponentially with v_{BE} . A plot of this variation is given in Fig. 2. It can be seen from the plot that the collector current is essentially zero until the base-to-emitter voltage reaches a threshold value. Above this value, the collector current increases rapidly. The threshold value is typically in the range of 0.5 to 0.6 V. For high current transistors, it is usually smaller. The plot shows a single curve. If v_{CE} is increased, the current for a given v_{BE} is larger. However, the displacement between the curves is so small that it can be difficult to distinguish between them. The small-signal transconductance g_m defined below is the slope of the transfer characteristics curve evaluated at the quiescent or dc operating point.

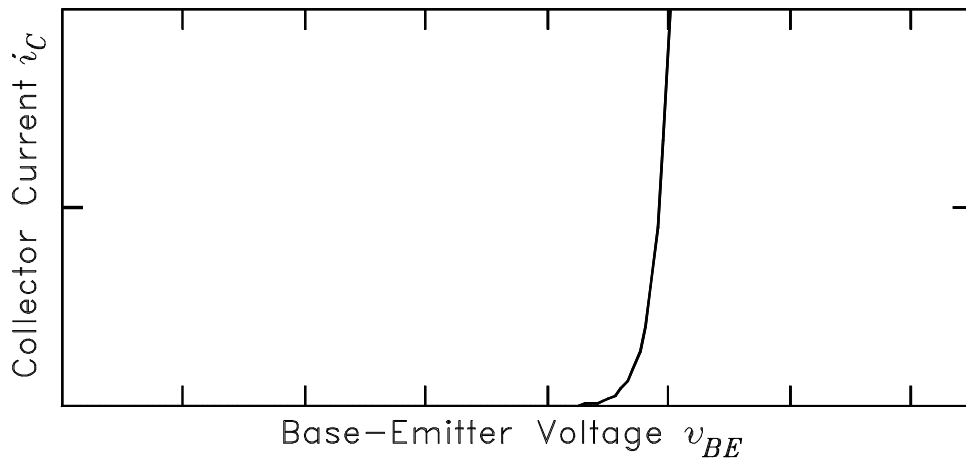

Figure 2: BJT transfer characteristics.

Output Characteristics

The output characteristics are a plot of the collector current i_C as a function of the collector-to-emitter voltage v_{CE} with the base current i_B held constant. From Eqs. 1 and 4, we can write

$$i_C = \beta_0 \left(1 + \frac{v_{CE}}{V_A} \right) i_B \quad (9)$$

It follows that i_C varies linearly with v_{CE} . A plot of this variation is given in Fig. 3. For small v_{CE} such that $0 \leq v_{CE} < v_{BE}$, Eq. (9) does not hold. This is the region on the left in Fig. 3. In this region, the BJT is saturated. The small-signal collector-to-emitter resistance r_0 defined below is the reciprocal of the slope of the transfer characteristics curve evaluated at the quiescent or dc operating point to the right of the saturation region in Fig. 3.

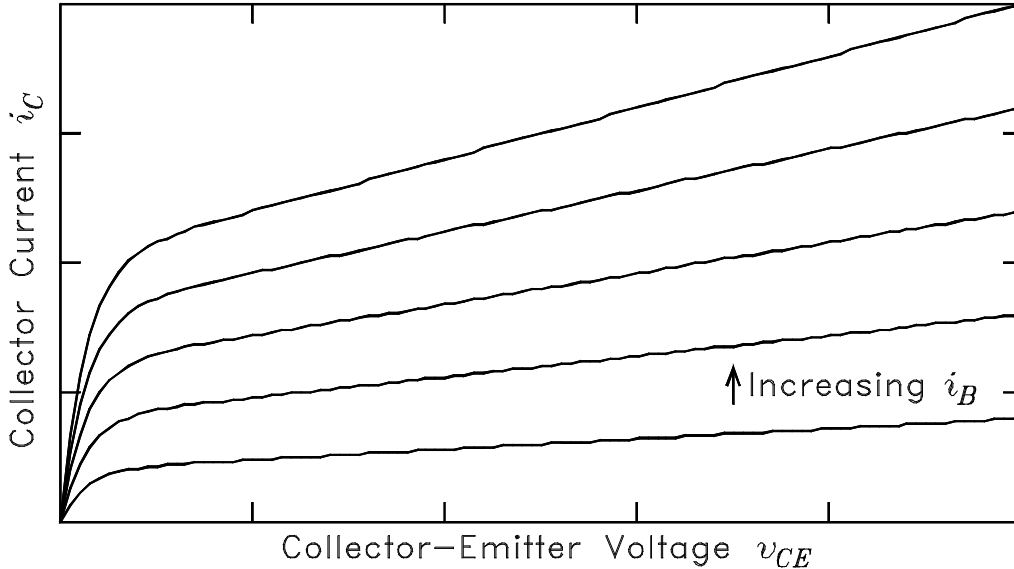

Figure 3: BJT output characteristics.

Hybrid- π Model

Let each current and voltage be written as the sum of a dc component and a small-signal ac component as follows:

$$i_C = I_C + i_c \quad i_B = I_B + i_b \quad (10)$$

$$v_{BE} = V_{BE} + v_{be} \quad v_{CE} = V_{CE} + v_{ce} \quad (11)$$

If the ac components are sufficiently small, we can write

$$i_c = \frac{\partial I_C}{\partial V_{BE}} v_{be} + \frac{\partial I_C}{\partial V_{CE}} v_{ce} \quad i_b = \frac{\partial I_B}{\partial V_{BE}} v_{be} \quad (12)$$

where the derivatives are evaluated at the dc bias values. The transconductance g_m , the collector-to-emitter resistance r_0 , and the base-to-emitter resistance r_π are defined as follows:

$$g_m = \frac{\partial I_C}{\partial V_{BE}} = \frac{I_S}{V_T} \exp\left(\frac{V_{BE}}{V_T}\right) = \frac{I_C}{V_T} \quad (13)$$

$$r_0 = \left(\frac{\partial I_C}{\partial V_{CE}} \right)^{-1} = \left[\frac{I_{S0}}{V_A} \exp \left(\frac{V_{BE}}{V_T} \right) \right]^{-1} = \frac{V_A + V_{CE}}{I_C} \quad (14)$$

$$r_\pi = \left(\frac{\partial I_B}{\partial V_{BE}} \right)^{-1} = \left[\frac{I_{S0}}{\beta_0 V_T} \exp \left(\frac{V_{BE}}{V_T} \right) \right]^{-1} = \frac{V_T}{I_B} \quad (15)$$

It is convenient to define the current i'_c as follows:

$$i'_c = g_m v_\pi \quad \text{where} \quad v_\pi = v_{be} \quad (16)$$

It follows that the collector and base currents can thus be written

$$i_c = i'_c + \frac{v_{ce}}{r_0} \quad i_b = \frac{v_\pi}{r_\pi} \quad (17)$$

The small-signal circuit which models these equations is given in Fig. 4(a). This is called the hybrid- π model. The resistor r_x in series with the base is called the base spreading resistance. This resistor arises from the resistance of the base connection. There is no equation for it for it must be measured. It is often neglected in small-signal analyses.

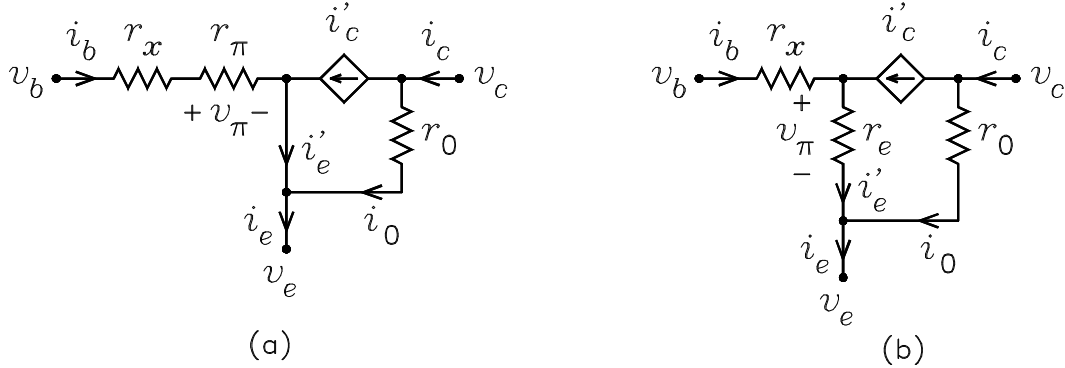

Figure 4: Rev(a) Hybrid- π model. (b) T model.

The small-signal base-to-collector ac current gain β is defined as the ratio i'_c/i_b . It is given by

$$\beta = \frac{i'_c}{i_b} = \frac{g_m v_\pi}{i_b} = g_m r_\pi = \frac{I_C}{V_T} \times \frac{V_T}{I_B} = \frac{I_C}{I_B} \quad (18)$$

Note that i_c differs from i'_c by the current through r_0 . Therefore, $i_c/i_b \neq \beta$ unless $r_0 = \infty$.

T Model

The T model replaces the resistor r_π in series with the base with a resistor r_e in series with the emitter. This resistor is called the emitter intrinsic resistance. The current i'_e can be written

$$i'_e = i_b + i'_c = \left(\frac{1}{\beta} + 1 \right) i'_c = \frac{1 + \beta}{\beta} i'_c = \frac{i'_c}{\alpha} \quad (19)$$

where α is the small-signal emitter-to-collector ac current gain given by

$$\alpha = \frac{\beta}{1 + \beta} \quad (20)$$

Thus the current i'_c can be written

$$i'_c = \alpha i'_e \quad (21)$$

The voltage v_π can be related to i'_e as follows:

$$v_\pi = i_b r_\pi = \frac{i'_c}{\beta} r_\pi = \frac{\alpha i'_e}{\beta} r_\pi = i'_e \frac{\alpha r_\pi}{\beta} = i'_e \frac{r_\pi}{1 + \beta} = i'_e r_e \quad (22)$$

The above equation defines the intrinsic emitter resistance r_e given by

$$r_e = \frac{v_\pi}{i'_e} = \frac{r_\pi}{1 + \beta} = \frac{V_T}{(1 + \beta) I_B} = \frac{V_T}{I_E} \quad (23)$$

The T model of the BJT is shown in Fig. 4(b). The currents in both models are related by the equations

$$i'_c = g_m v_\pi = \beta i_b = \alpha i'_e \quad (24)$$

The Collector Equivalent Circuit

If the BJT output is taken from the collector, the input can be either applied to the base or to the emitter. If it is applied to the base, the circuit is called a common-emitter amplifier. If it is applied to the emitter, the circuit is called a common-base amplifier. In some cases, separate inputs can be applied to both the base and the emitter. In any of these cases, the collector output can be solved for by first making a small-signal Thévenin or Norton equivalent circuit seen looking into the collector. We solve for the Norton equivalent circuit here. We assume that the circuits external to the base and the emitter can be represented by Thévenin equivalents.

Figure 5(a) shows the BJT symbol with separate Thévenin sources connected to the base and the emitter. The bias circuits are not shown, but we assume that the bias solutions are known. Figure 5(b) shows the circuit with the BJT replaced with the hybrid- π model.

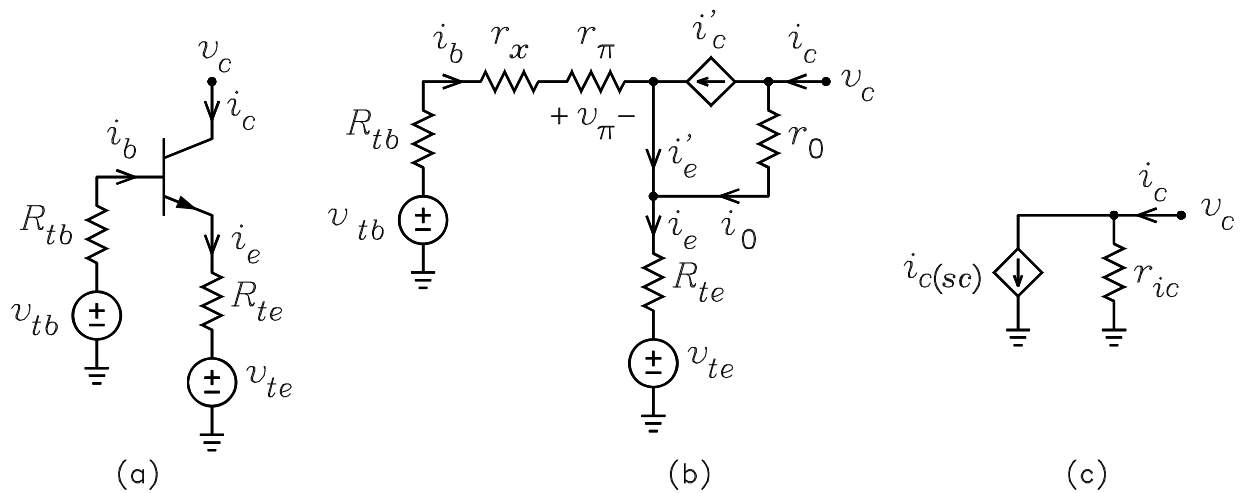

Figure 5: (a) BJT symbol with Thévenin sources connected to the base and the emitter. (b) Circuit with the BJT replaced with the hybrid- π model. (c) Norton equivalent collector circuit.

The Norton equivalent circuit seen looking into the collector consists of a parallel current source $i_{c(sc)}$ and resistor r_{ic} connecting between the collector and ground. This is shown in Figure 5(c).

The value of $i_{c(sc)}$ is the collector current with $v_c = 0$, i.e. with the collector node grounded. From Figure 5(b), this current is given by

$$i_{c(sc)} = i'_c + i_0 \simeq i'_c \quad (25)$$

where the approximation assumes that the current i_0 through r_0 is small compared to i'_c . This is usually a very good approximation because r_0 is a large value resistor. We call it the “ r_0 approximation” when the current i_0 is neglected. In many cases, r_0 is taken to be an infinite resistor, in which case the approximation is exact.

To solve for i'_c , we can write the loop equation

$$\begin{aligned} v_{tb} - v_{te} &= i_b (R_{tb} + r_x + r_\pi) + (i'_e + i_0) R_{te} \\ &= \frac{i'_c}{\beta} (R_{tb} + r_x + r_\pi) + \left(\frac{i'_c}{\alpha} + i_0 \right) R_{te} \\ &\simeq i'_c \left(\frac{R_{tb} + r_x + r_\pi}{\beta} + \frac{R_{te}}{\alpha} \right) \end{aligned} \quad (26)$$

where the relations $i_b = i'_c/\beta$ and $i'_e = i'_c/\alpha$ have been used. An alternate way of writing this equation is to use the relation $v_\pi = i'_c/g_m$ for v_π as follows:

$$\begin{aligned} v_{tb} - v_{te} &= i_b (R_{tb} + r_x) + v_\pi + (i'_e + i_0) R_{te} \\ &= \frac{i'_c}{\beta} (R_{tb} + r_x) + \frac{i'_c}{g_m} + \left(\frac{i'_c}{\alpha} + i_0 \right) R_{te} \\ &\simeq i'_c \left(\frac{R_{tb} + r_x}{\beta} + \frac{1}{g_m} + \frac{R_{te}}{\alpha} \right) \end{aligned} \quad (27)$$

It follows from both equations that we can write

$$i_{c(sc)} = i'_c = G_m (v_{tb} - v_{te}) \quad (28)$$

where G_m is an equivalent transconductance given by either of the equations

$$G_m = \frac{1}{\frac{R_{tb} + r_x + r_\pi}{\beta} + \frac{R_{te}}{\alpha}} \stackrel{\text{or}}{=} \frac{1}{\frac{R_{tb} + r_x}{\beta} + \frac{1}{g_m} + \frac{R_{te}}{\alpha}} \stackrel{\text{or}}{=} \frac{1}{\frac{R_{tb} + r_x}{\beta} + \frac{r_e + R_{te}}{\alpha}} \quad (29)$$

The third equation follows from the relation $r_e/\alpha = 1/g_m = r_\pi/\beta$. It would be obtained directly if the T model is used.

We next solve for the resistance r_{ic} seen looking into the collector node. Consider the collector current i_c to be an independent current source and set $v_{tb} = v_{te} = 0$. Using superposition, we can write

$$v_c = i_c [r_0 + (R_{tb} + r_x + r_\pi) \parallel R_{te}] - \beta i_b r_0 \quad (30)$$

where $i'_c = \beta i_b$ has been used. Current division can be used to express i_b in this equation in terms of i_c as follows:

$$i_b = -i_c \frac{R_{te}}{R_{tb} + r_x + r_\pi + R_{te}} \quad (31)$$

Substitution of this equation for i_b into the the equation for v_c yields

$$v_c = i_c \left[r_0 + (R_{tb} + r_x + r_\pi) \parallel R_{te} + \frac{\beta R_{te}}{R_{tb} + r_x + r_\pi + R_{te}} r_0 \right] \quad (32)$$

It follows that the collector resistance is given by

$$r_{ic} = \frac{v_c}{i_c} = r_0 \left(1 + \frac{\beta R_{te}}{R_{tb} + r_x + r_\pi + R_{te}} \right) + (R_{tb} + r_x + r_\pi) \parallel R_{te} \quad (33)$$

Note that no approximations have been made in solving for r_{ic} .

In summary, the small-signal Norton equivalent circuit seen looking into the collector of a BJT is a current source $i_{c(sc)}$ in parallel with a resistor r_{ic} given by

$$i_{c(sc)} = i'_c = G_m (v_{tb} - v_{te}) \quad (34)$$

$$G_m = \frac{1}{\frac{R_{tb} + r_x + r_\pi}{\beta} + \frac{R_{te}}{\alpha}} \stackrel{\text{or}}{=} \frac{1}{\frac{R_{tb} + r_x}{\beta} + \frac{1}{g_m} + \frac{R_{te}}{\alpha}} \stackrel{\text{or}}{=} \frac{1}{\frac{R_{tb} + r_x}{\beta} + \frac{r_e + R_{te}}{\alpha}} \quad (35)$$

$$r_{ic} = r_0 \left(1 + \frac{\beta R_{te}}{R_{tb} + r_x + r_\pi + R_{te}} \right) + (R_{tb} + r_x + r_\pi) \parallel R_{te} \quad (36)$$

where v_{tb} and v_{te} , respectively, are the Thévenin voltages seen looking out of the base and emitter and R_{tb} and R_{te} are the corresponding Thévenin resistances.

Example 1 Figure 6(a) shows the signal equivalent circuit of a common-emitter amplifier. It is given that $R_{tb} = 1 \text{ k}\Omega$, $R_{te} = 50 \Omega$, $R_C = 10 \text{ k}\Omega$, $I_C = 1 \text{ mA}$, $\beta = 100$, $r_x = 0$, $r_0 = 50 \text{ k}\Omega$, and $V_T = 25 \text{ mV}$. Solve for the voltage gain and output resistance of the circuit.

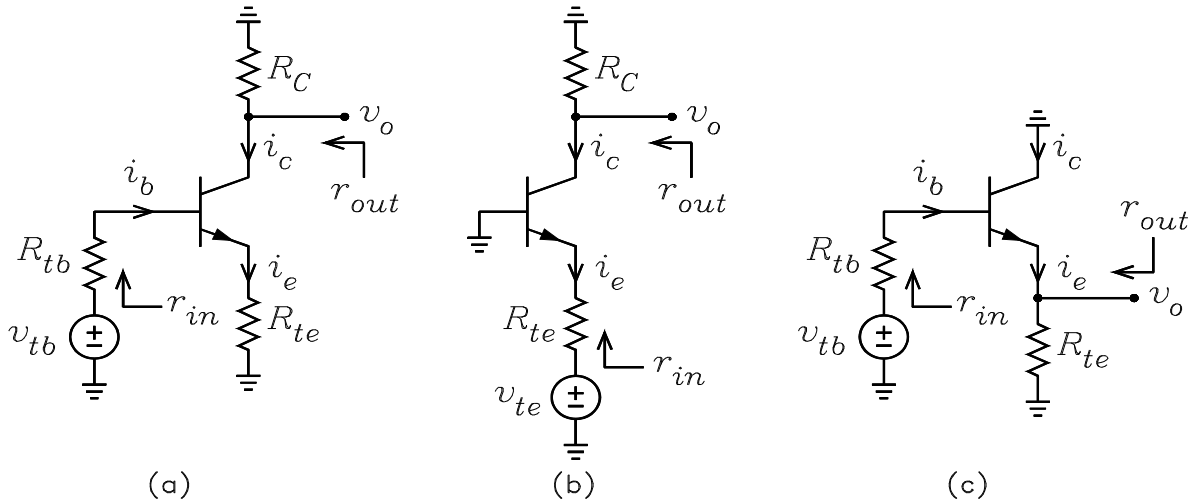

Figure 6: (a) Common-emitter amplifier. (b) Common-base amplifier. (c) Common-collector amplifier.

Solution: $I_B = I_C/\beta = 0.01 \text{ mA}$, $\alpha = \beta/(1 + \beta) = 0.990$, $I_E = I_C/\alpha = 1.01 \text{ mA}$, $r_\pi = V_T/I_B = 2.5 \text{ k}\Omega$, $g_m = I_C/V_T = 0.04 \text{ S}$, $r_e = V_T/I_E = 25/1.01 = 24.8 \Omega$.

A flow graph for the voltage gain is shown in Figure 7(a). From the flow graph, we can write

$$\frac{v_o}{v_{tb}} = \frac{i'_c}{v_{tb}} \times \frac{v_o}{i'_c} = G_m \times -(r_{ic} \parallel R_C)$$

The numerical values are

$$G_m = \frac{1}{\frac{R_{tb} + r_x + r_\pi}{\beta} + \frac{R_{te}}{\alpha}} = \frac{1}{\frac{1\text{k} + 2.5\text{k}}{100} + \frac{50}{0.990}} = \frac{1}{85.5}$$

$$r_{ic} = r_0 \left(1 + \frac{\beta R_{te}}{R_{tb} + r_x + r_\pi + R_{te}} \right) + (R_{tb} + r_x + r_\pi) \parallel R_{te}$$

$$= 50\text{k} \left(1 + \frac{100 \times 50}{1\text{k} + 2.5\text{k} + 50} \right) + \frac{(1\text{k} + 2.5\text{k}) \times 50}{1\text{k} + 2.5\text{k} + 50} = 120\text{k}\Omega$$

$$\frac{v_o}{v_{tb}} = G_m \times -(r_{ic} \parallel R_C) = \frac{1}{85.5} \times -\frac{120\text{k} \times 10\text{k}}{120\text{k} + 10\text{k}} = -108$$

$$r_{out} = r_{ic} \parallel R_C = \frac{120\text{k} \times 10\text{k}}{120\text{k} + 10\text{k}} = 9.23\text{k}\Omega$$

Because the gain is negative, the amplifier is said to be an inverting amplifier.



Figure 7: (a) Flow graph for the CE amplifier. (b) Flow graph for the CB amplifier.

Example 2 Figure 6(b) shows the signal equivalent circuit of a common-base amplifier. It is given that $R_{te} = 100\Omega$, $R_C = 10\text{k}\Omega$, $I_C = 1\text{mA}$, $\beta = 100$, $r_0 = 50\text{k}\Omega$, $r_x = 0$, and $V_T = 25\text{mV}$. Solve for the voltage gain and output resistance of the circuit.

Solution: $I_B = I_C/\beta = 0.01\text{mA}$, $\alpha = \beta/(1 + \beta) = 0.990$, $I_E = I_C/\alpha = 1.01\text{mA}$, $r_\pi = V_T/I_B = 2.5\text{k}\Omega$, $g_m = I_C/V_T = 0.04\text{S}$, $r_e = V_T/I_E = 24.8\Omega$.

A flow graph for the voltage gain is shown in Figure 7(b). From the flow graph, we can write

$$\frac{v_o}{v_{te}} = \frac{i'_c}{v_{te}} \times \frac{v_o}{i'_c} = -G_m \times -(r_{ic} \parallel R_C)$$

The numerical values are

$$G_m = \frac{1}{\frac{r_x + r_\pi}{\beta} + \frac{R_{te}}{\alpha}} = \frac{1}{\frac{2.5\text{k}}{100} + \frac{100}{0.99}} = \frac{1}{126}$$

$$r_{ic} = r_0 \left(1 + \frac{\beta R_{te}}{r_x + r_\pi + R_{te}} \right) + (r_x + r_\pi) \parallel R_{te}$$

$$= 50\text{k} \left(1 + \frac{100 \times 100}{2.5\text{k} + 100} \right) + \frac{2.5\text{k} \times 100}{2.5\text{k} + 100} = 242\text{k}\Omega$$

$$\frac{v_o}{v_{te}} = -G_m \times -(r_{ic} \parallel R_C) = -\frac{1}{126} \times -\frac{242\text{k} \times 10\text{k}}{242\text{k} + 10\text{k}} = 79.0$$

$$r_{out} = r_{ic} \parallel R_C = \frac{242\text{k} \times 10\text{k}}{242\text{k} + 10\text{k}} = 9.6\text{k}\Omega$$

Because the gain is positive, the amplifier is said to be a non-inverting amplifier.

The Base Equivalent Circuit

Figure 8(a) shows the BJT symbol with a Thévenin source connected to the emitter. The bias circuits are not shown, but we assume that the bias solutions are known. We wish to solve for the small-signal Thévenin equivalent circuit seen looking into the base. Figure 8(b) shows the circuit with the BJT replaced with the hybrid- π model. The base spreading resistance r_x is omitted because it can be assumed to be part of the external base circuit. We wish to solve for the Thévenin equivalent circuit seen looking into the base.

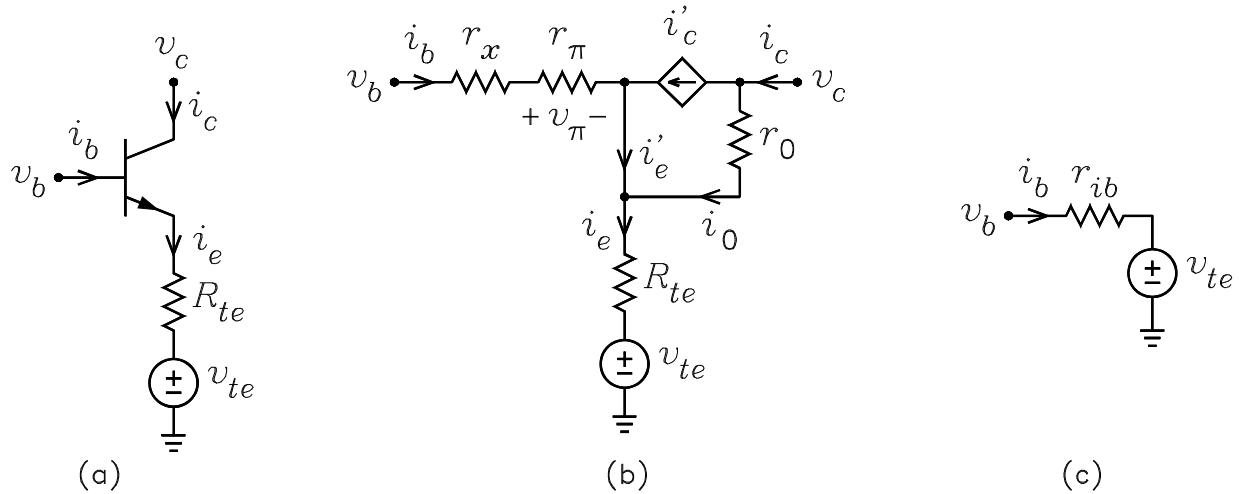

Figure 8: (a) BJT symbol with Thévenin source connected to the emitter. (b) Circuit with the BJT replaced with the hybrid- π model. (c) Thévenin equivalent base circuit.

From the circuit in figure 8(b), we can write

$$\begin{aligned} v_b &= i_b (r_x + r_\pi) + (i'_e + i_0) R_{te} + v_{te} \simeq i_b (r_x + r_\pi) + i'_e R_{te} + v_{te} \\ &= i_b [r_x + r_\pi + (1 + \beta) R_{te}] + v_{te} \end{aligned} \quad (37)$$

where we assume that i_0 is small compared to i'_e and the relation $i'_e = (1 + \beta) i_b$ has been used. It follows that the Thévenin equivalent circuit seen looking into the base is a source v_{te} in series with a resistance r_{ib} given by

$$r_{ib} = r_x + r_\pi + (1 + \beta) R_{te} = r_x + (1 + \beta) (r_e + R_{te}) \quad (38)$$

where the relation $r_\pi = (1 + \beta) r_e$ has been used in the second form. The equivalent circuit is shown in Figure 8(c). The resistor R_{te} does not appear in this circuit because it is absorbed into r_{ib} .

With the definition of r_{ib} , we can define another way of calculating $i_{c(sc)}$ in the Norton collector circuit. The current i_b in Figure 5(a) is given by

$$i_b = \frac{v_{tb} - v_{te}}{R_{tb} + r_{ib}} \quad (39)$$

Because $i'_c = \beta i_b$ and $i_{c(sc)} = i'_c = G_m (v_{tb} - v_{te})$, we have a fourth equation for G_m given by

$$G_m = \frac{\beta}{R_{tb} + r_{ib}} \quad (40)$$

Example 3 Solve for the input resistance r_{in} of the common-emitter amplifier of Example 1.

Solution:

$$r_{in} = R_{tb} + r_x + r_{ib} = R_{tb} + r_x + r_\pi + (1 + \beta) R_{te} = 1\text{k} + 2.5\text{k} + 101 \times 50 = 8.55\text{ k}\Omega$$

The Emitter Equivalent Circuit

Figure 9(a) shows the BJT symbol with a Thévenin source connected to the base. The bias circuits are not shown, but we assume that the bias solutions are known. We wish to solve for the small-signal Thévenin equivalent circuit seen looking into the emitter. Figure 9(b) shows the circuit with the BJT replaced with the hybrid- π model. The base spreading resistance r_x is omitted because it can be assumed to be part of R_{tb} .

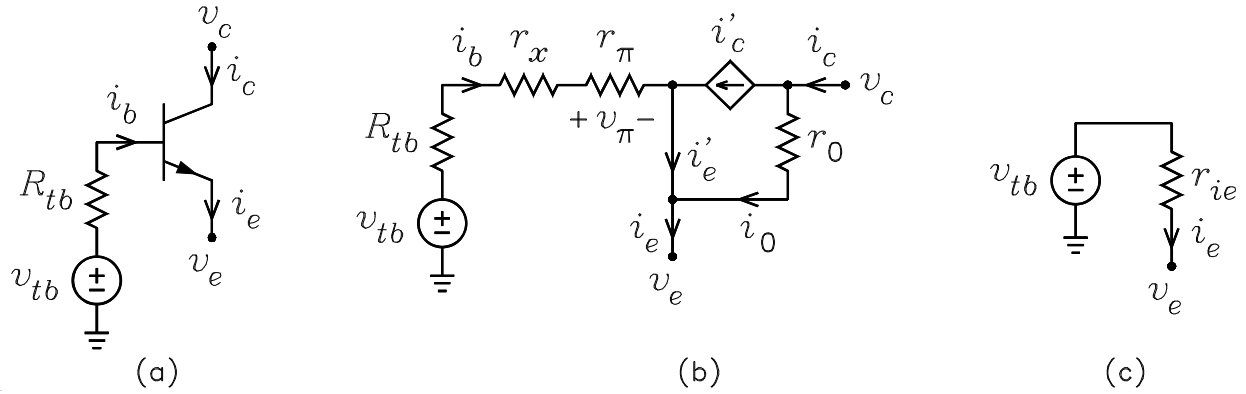

Figure 9: (a) BJT symbol with a Thévenin source connected to the base. (b) Circuit with the BJT replaced with its hybrid- π model. (c) Thévenin emitter equivalent circuit.

From the circuit in 9(b), we can write

$$\begin{aligned} v_e &= v_{tb} - i_b (R_{tb} + r_x + r_\pi) \\ &= v_{tb} - \frac{i'_e}{1 + \beta} (R_{tb} + r_x + r_\pi) \\ &= v_{tb} - \frac{i_e - i_0}{1 + \beta} (R_{tb} + r_x + r_\pi) \\ &\simeq v_{tb} - \frac{i_e}{1 + \beta} (R_{tb} + r_x + r_\pi) \end{aligned} \quad (41)$$

where the approximation assumes i_0 is small compared to i_e and the relation $i_b = i'_e / (1 + \beta)$ has been used. It follows that the Thévenin equivalent circuit seen looking into the emitter is a source v_{tb} in series with a resistance r_{ie} given by

$$r_{ie} = \frac{R_{tb} + r_x + r_\pi}{1 + \beta} \text{ or } \frac{R_{tb} + r_x}{1 + \beta} + r_e \quad (42)$$

where the relation $r_e = r_\pi / (1 + \beta)$ has been used in the second expression. The equivalent circuit is shown in Figure 9(c). There is no R_{tb} in this circuit because it has been absorbed into r_{ie} .

With the definition of r_{ie} , we can define another way of calculating $i_{c(sc)}$ in the Norton collector circuit. The current i_e in Figure 5(a) is given by

$$i_e = \frac{v_{tb} - v_{te}}{r_{ie} + R_{te}} \quad (43)$$

Because $i'_c = \alpha i'_e \simeq \alpha i_e$ and $i_{c(sc)} = i'_c = G_m (v_{tb} - v_{te})$, we have a fifth equation for G_m given by

$$G_m = \frac{\alpha}{r_{ie} + R_{te}} \quad (44)$$

Example 4 Solve for the input resistance of the common-base amplifier of Example 2.

Solution:

$$r_{in} = r_{ie} + R_{te} = \frac{r_x + r_\pi}{1 + \beta} + R_{te} = \frac{2.5\text{k}}{101} + 100 = 125 \Omega$$

Example 5 Figure 6(c) shows the signal equivalent circuit of a common-collector amplifier. It is given that $R_{tb} = 10 \text{ k}\Omega$, $R_{te} = 1 \text{ k}\Omega$, $I_C = 1 \text{ mA}$, $\beta = 100$, $r_x = 0$, $r_0 = 50 \text{ k}\Omega$, and $V_T = 25 \text{ mV}$. Solve for the voltage gain, the input resistance, and the output resistance of the circuit.

Solution: $I_B = I_C/\beta = 0.01 \text{ mA}$, $\alpha = \beta/(1 + \beta) = 100/101$, $I_E = I_C/\alpha = 1.01 \text{ mA}$, $r_\pi = V_T/I_B = 2.5 \text{ k}\Omega$, $g_m = I_C/V_T = 0.04 \text{ S}$, $r_e = V_T/I_E = 25/1.01 = 24.8 \Omega$.

$$r_{ie} = \frac{R_{tb} + r_x + r_\pi}{1 + \beta} = \frac{10\text{k} + 2.5\text{k}}{101} = 124 \Omega$$

$$G_m = \frac{1}{r_{ie} + R_{te}} = \frac{1}{124 + 1\text{k}} = \frac{1}{1124} \text{ S}$$

The input and output resistances are given by

$$r_{in} = R_{tb} + r_{ib} = R_{tb} + r_x + r_\pi + (1 + \beta) R_{te} = 10\text{k} + 2.5\text{k} + 101\text{k} \times 1\text{k} = 114 \text{ k}\Omega$$

$$r_{out} = r_{ie} \parallel R_{te} = \frac{124 \times 1\text{k}}{124 + 1\text{k}} = 122 \Omega$$

Two possible flow graphs for the solution are shown in Figure 10.

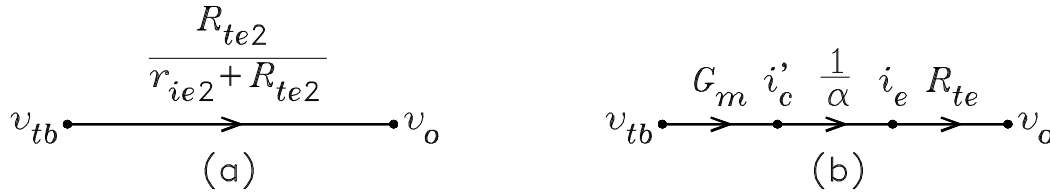

Figure 10: Flow graphs for the common-collector amplifier.

The first solution is illustrated in Figure 10(a), where voltage division is used to solve for the gain.

$$\frac{v_o}{v_{tb}} = \frac{R_{te}}{r_{ie} + R_{te}} = \frac{1\text{k}}{124 + 1\text{k}} = 0.890$$

The second solution is illustrated in Figure 10(b). The voltage gain is

$$\frac{v_o}{v_{tb}} = \frac{i'_c}{v_{tb}} \times \frac{i_e}{i'_c} \times \frac{v_o}{i_e} = G_m \times \frac{1}{\alpha} \times R_{te} = \frac{1}{1124} \times \frac{101}{100} \times 1\text{k} = 0.890$$

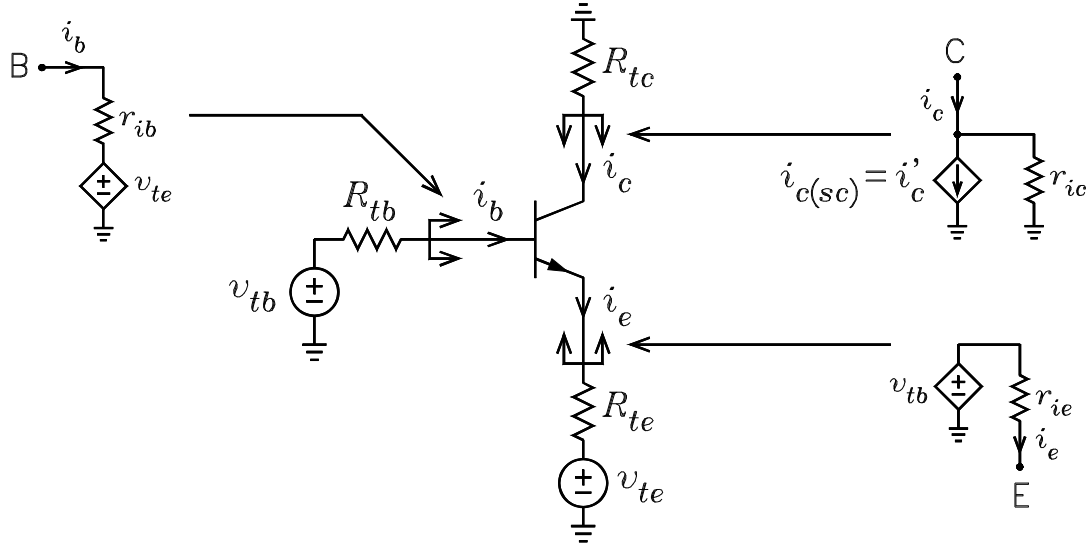

Figure 11: Summary of the collector, base, and emitter models.

Summary of Models

$$r_{ib} = r_x + r_\pi + (1 + \beta) R_{te} \stackrel{\text{or}}{=} r_x + (1 + \beta) (r_e + R_{te}) \quad (45)$$

$$r_{ie} = \frac{R_{tb} + r_x + r_\pi}{1 + \beta} \stackrel{\text{or}}{=} \frac{R_{tb} + r_x}{1 + \beta} + r_e \quad (46)$$

$$i_{c(sc)} = i'_c = G_m (v_{tb} - v_{te}) \quad (47)$$

$$\begin{aligned} G_m &= \frac{1}{\frac{R_{tb} + r_x + r_\pi}{\beta} + \frac{R_{te}}{\alpha}} \stackrel{\text{or}}{=} \frac{1}{\frac{R_{tb} + r_x}{\beta} + \frac{1}{g_m} + \frac{R_{te}}{\alpha}} \\ &\stackrel{\text{or}}{=} \frac{1}{\frac{R_{tb} + r_x}{\beta} + \frac{r_e + R_{te}}{\alpha}} \stackrel{\text{or}}{=} \frac{\beta}{R_{tb} + r_{ib}} \stackrel{\text{or}}{=} \frac{\alpha}{r_{ie} + R_{tb}} \end{aligned} \quad (48)$$

$$\begin{aligned} r_{ic} &= r_0 \left(1 + \frac{\beta R_{te}}{R_{tb} + r_x + r_\pi + R_{te}} \right) + (R_{tb} + r_x + r_\pi) \parallel R_{te} \\ &= \frac{r_0 + r_{ie} \parallel R_{te}}{1 - \alpha R_{te} / (r_{ie} + R_{te})} \end{aligned} \quad (49)$$

The second equation for r_{ic} is more compact and can be derived from the T model.

A CE/CC Amplifier

Figure 12(a) shows the ac signal circuit of a two-stage amplifier consisting of a CE stage followed by a CC stage. Such a circuit is used to obtain a high voltage gain and a low output resistance.

To write the gain expression, we use the Norton collector circuit for Q_1 and the Thévenin emitter circuit for Q_2 . A flow graph for the voltage gain is shown in Figure 13.

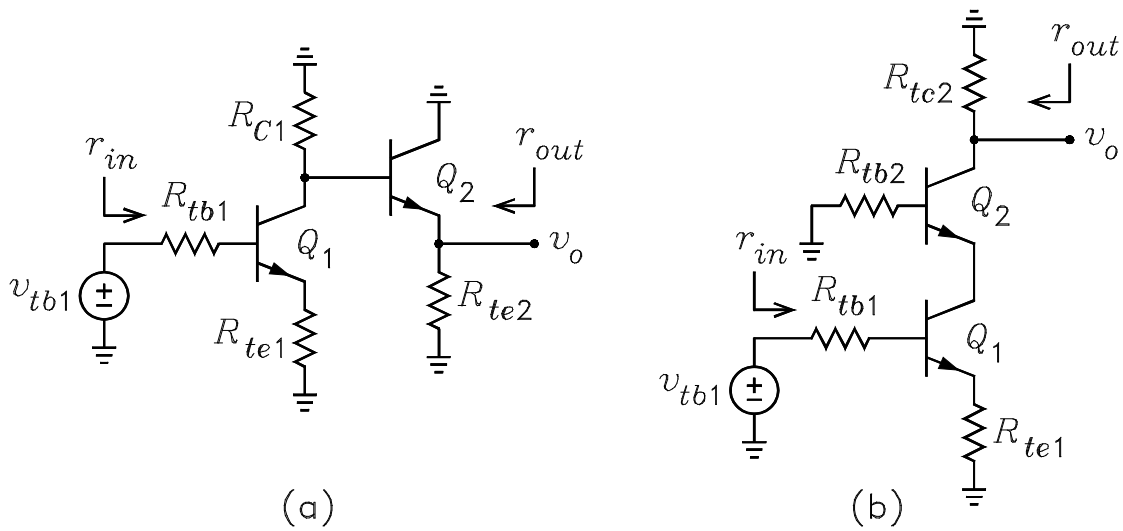

Figure 12: (a) A CE/CC amplifier. (b) A CE/CB amplifier.

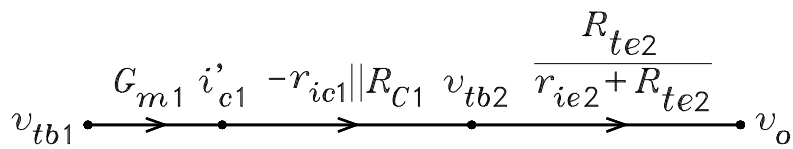

Figure 13: Flow graph for the voltage gain of the CE/CC amplifier.

From the flow graph, the voltage gain can be written

$$\begin{aligned}\frac{v_o}{v_{tb1}} &= \frac{i'_{c1}}{v_{tb1}} \times \frac{v_{tb2}}{i'_{c1}} \times \frac{v_o}{v_{tb2}} \\ &= G_{m1} \times -(r_{ic1} \parallel R_{C1}) \times \frac{R_{te2}}{r_{ie2} + R_{te2}}\end{aligned}\quad (50)$$

where r_{ie2} is calculated with $R_{tb2} = r_{ic1} \parallel R_{C1}$ and

$$r_{ic1} = r_{o1} \parallel \left(1 + \frac{\beta R_{te1}}{R_{tb1} + r_{x1} + r_{\pi1} + R_{te1}} \right) + R_{te1} \parallel (R_{tb1} + r_{x1} + r_{\pi1})$$

The input and output resistances are given by

$$r_{in} = R_{tb1} + r_{ib1} = R_{tb1} + r_{x1} + r_{\pi1} + (1 + \beta) R_{te1} \quad (51)$$

$$r_{out} = r_{ie2} \parallel R_{te2} = \frac{R_{tb1} + r_{x1} + r_{\pi1}}{1 + \beta} \parallel R_{te2} \quad (52)$$

The circuit is an inverting amplifier consisting of an inverting stage followed by a non-inverting stage.

Example 6 For the CE/CC amplifier in Figure 12(a) it is given that $R_{tb1} = 1 \text{ k}\Omega$, $R_{te1} = 50 \Omega$, $R_{C1} = 20 \text{ k}\Omega$, and $R_{te2} = 200 \Omega$. For both transistors, $I_C = 1 \text{ mA}$, $\beta = 100$, $r_x = 0$, $r_o = 50 \text{ k}\Omega$, and $V_T = 25 \text{ mV}$. Solve for the voltage gain, input resistance, and output resistance of the circuit.

Solution: $I_B = I_C/\beta = 0.01 \text{ mA}$, $\alpha = \beta/(1 + \beta) = 100/101$, $I_E = I_C/\alpha = 1.01 \text{ mA}$, $r_\pi = V_T/I_B = 2.5 \text{ k}\Omega$, $g_m = I_C/V_T = 0.04 \text{ S}$, $r_e = V_T/I_E = 25/1.01 = 24.8 \Omega$.

$$G_{m1} = \frac{1}{\frac{R_{tb1} + r_x + r_\pi}{\beta} + \frac{R_{te1}}{\alpha}} = \frac{1}{\frac{1\text{k} + 2.5\text{k}}{100} + \frac{50}{0.990}} = \frac{1}{85.5}$$

$$\begin{aligned}r_{ic1} &= r_o \left(1 + \frac{\beta R_{te}}{R_{tb} + r_x + r_\pi + R_{te}} \right) + (R_{tb} + r_x + r_\pi) \parallel R_{te} \\ &= 50\text{k} \left(1 + \frac{100 \times 50}{1\text{k} + 2.5\text{k} + 50} \right) + (1\text{k} + 2.5\text{k}) \parallel 50 = 120 \text{ k}\Omega\end{aligned}$$

$$r_{ie2} = \frac{R_{tb2} + r_x + r_\pi}{1 + \beta} = \frac{R_{C1} \parallel r_{ic1} + r_x + r_\pi}{1 + \beta} = \frac{10\text{k} \parallel 120\text{k} + 2.5\text{k}}{101} = 116 \Omega$$

$$\frac{v_o}{v_{tb1}} = G_{m1} \times [-(r_{ic1} \parallel R_{C1})] \times \frac{R_{te2}}{r_{ie2} + R_{te2}} = -\frac{1}{85.5} \times 120\text{k} \parallel 20\text{k} \times \frac{200}{116 + 200} = -127$$

$$r_{in} = R_{tb1} + r_{ib1} = 1\text{k} + 2.5\text{k} + 101 \times 50 = 8.55 \text{ k}\Omega$$

$$r_{out} = r_{ie2} \parallel R_{te2} = \frac{116 \times 200}{116 + 200} = 73.4 \Omega$$

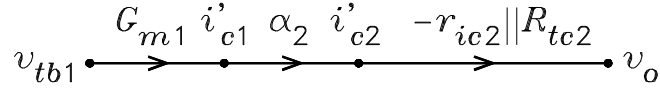

Figure 14: Flow graph for the voltage gain.

A Cascode Amplifier

Figure 12(b) shows the ac signal circuit of a cascode amplifier. A flow graph for the voltage gain is shown in Figure 14. To write the gain expression, we use the Norton collector circuits for both Q_1 and Q_2 .

From the flow graph, we can write

$$\frac{v_o}{v_{tb1}} = \frac{i'_{c1}}{v_{tb1}} \times \frac{i'_{c2}}{i'_{c1}} \times \frac{v_o}{i'_{c2}} = G_{m1} \times \alpha_2 \times -r_{ic2} || R_{tc2}$$

Note that setting $i_{c2(sc)}/i_{c1(sc)} = \alpha_2$ is an approximation that neglects the current through r_{o1} . The input and output resistances are given by

$$r_{in} = R_{tb1} + r_{ib1}$$

$$r_{out} = R_{tc2}$$

The resistance seen looking out of the collector of Q_1 is r_{ie2} . The circuit is a non-inverting amplifier consisting of two inverting stages in cascade.

A second cascode amplifier is shown in Fig. 16(a) where a pnp transistor is used for the second stage. In this circuit, we consider i_{e2} to be positive into the emitter and i_{c2} to be positive out of the collector. A flow graph for the voltage gain is shown in Figure 15. To write the gain expression, we use the Norton collector circuits for both Q_1 and Q_2 .

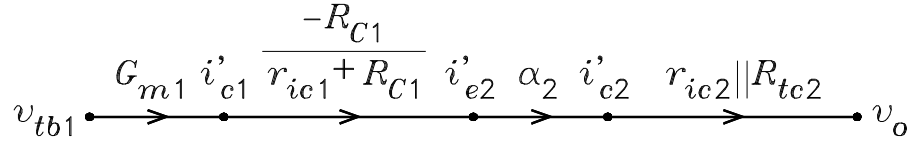

Figure 15: Flow graph for the voltage gain of the CE/CB amplifier.

From the flow graph, we can write

$$\frac{v_o}{v_{tb1}} = \frac{i'_{c1}}{v_{tb1}} \times \frac{i_{e2}}{i'_{c1}} \times \frac{i'_{c2}}{i_{e2}} \times \frac{v_o}{i'_{c2}} = G_{m1} \times \frac{-R_{C1}}{r_{ic1} + R_{C1}} \times \alpha_2 \times r_{ic2} || R_{tc2}$$

The expressions for r_{in} and r_{out} are the same as for the cascode amplifier in Fig. 12(b). If $R_{C1} \rightarrow \infty$, the gain expressions for the two cascode amplifiers are the same.

A Differential Amplifier

Figure 16(b) shows the ac signal circuit of a differential amplifier. For the case of an active tail bias supply, the resistor R_Q represents its small-signal ac resistance. We assume that the transistors

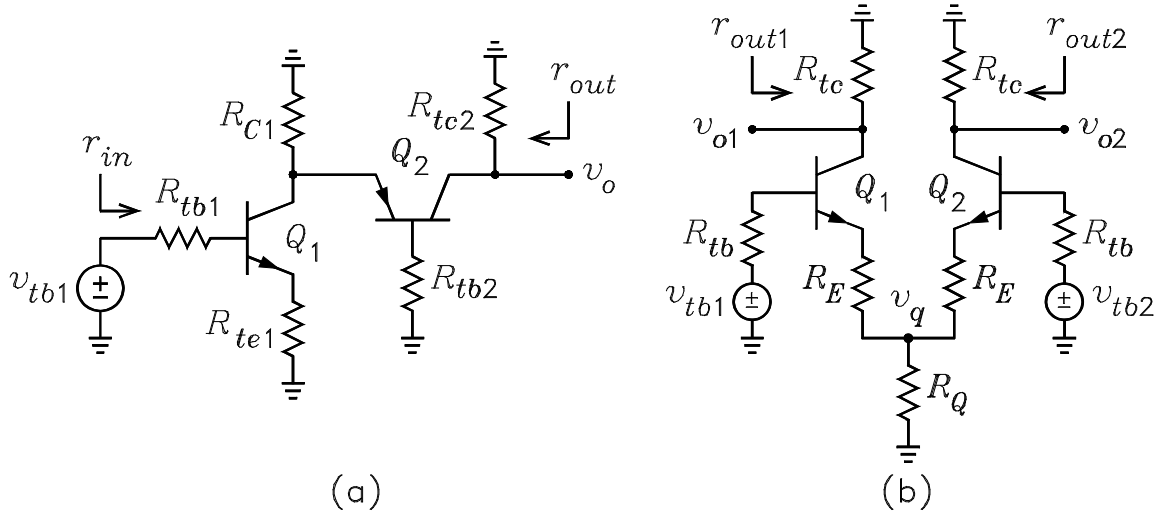

Figure 16: (a) Second cascode amplifier. (b) Differential amplifier.

are identical, biased at the same currents and voltages, and have identical small-signal parameters. Looking out of the emitter of Q_1 , the Thévenin voltage and resistance are given by

$$v_{te1} = v_{e2(oc)} \frac{R_Q}{R_Q + R_E + r_{ie}} = v_{tb2} \frac{R_Q}{R_Q + R_E + r_{ie}} \quad (53)$$

$$R_{te1} = R_E + R_Q \parallel (R_E + r_{ie}) \quad (54)$$

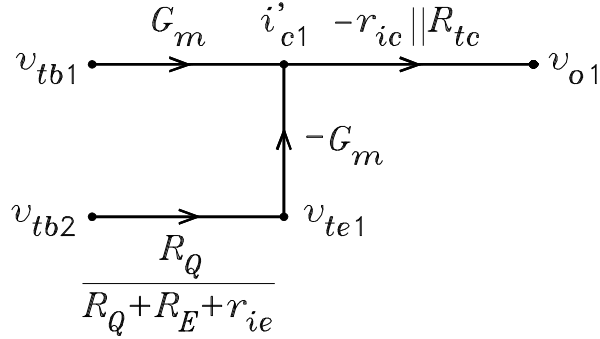

Figure 17: Flow graph for v_{o1} for the differential amplifier.

A flow graph for the v_{o1} output is shown in Figure 17. The small-signal collector voltage of Q_1 is given by

$$\begin{aligned} v_{o1} &= v_{tb1} \times G_m \times -(r_{ic} \parallel R_{tc}) + v_{tb2} \frac{R_Q}{R_Q + R_E + r_{ie}} \times -G_m \times -(r_{ic} \parallel R_{tc}) \\ &= -G_m \left(v_{tb1} - \frac{R_Q}{R_Q + R_E + r_{ie}} v_{tb2} \right) (r_{ic} \parallel R_{tc}) \end{aligned} \quad (55)$$

By symmetry, v_{o2} is obtained by interchanging the subscripts 1 and 2 in this equation. The small-signal resistance seen looking into either output is

$$r_{out} = R_{tc} \parallel r_{ic} \quad (56)$$

where r_{ic} calculated with $R_{te} = R_E + R_Q \parallel (R_E + r_{ie})$. The input resistance seen by either input with the other input grounded is $r_{in} = r_{ib}$.

If $R_Q \rightarrow \infty$, the expression for v_{o1} simplifies to

$$v_{o1} = -G_m (v_{tb1} - v_{tb2}) (r_{ic} \parallel R_{tc})$$

In this case $R_{te} = 2R_E + r_{ie}$. The output is proportional to the difference between the two input signals.

Differential and Common-Mode Gains

A second solution of the diff amp can be obtained by replacing v_{tb1} and v_{tb2} with differential and common-mode components as follows:

$$v_{tb1} = \frac{v_{tb1} - v_{tb2}}{2} + \frac{v_{tb1} + v_{tb2}}{2} = \frac{v_{i(d)}}{2} + v_{i(cm)} \quad (57)$$

$$v_{tb2} = \frac{v_{tb1} - v_{tb2}}{2} - \frac{v_{tb1} + v_{tb2}}{2} = \frac{v_{i(d)}}{2} - v_{i(cm)} \quad (58)$$

where $v_{i(d)}$ is the differential input voltage given by

$$v_{i(d)} = v_{tb1} - v_{tb2} \quad (59)$$

and $v_{i(cm)}$ is the common-mode input voltage given by

$$v_{i(cm)} = \frac{v_{tb1} + v_{tb2}}{2} \quad (60)$$

Superposition of $v_{i(d)}$ and $v_{i(cm)}$ can be used to solve for v_{o1} and v_{o2} . With $v_{i(cm)} = 0$, the effects of $v_{tb1} = v_{i(d)}/2$ and $v_{tb2} = -v_{i(d)}/2$ are to cause $v_q = 0$ in Figure 16. Thus the v_q node can be grounded and the circuit can be divided into two common-emitter stages in which $R_{te(d)} = R_E$ for each transistor. In this case, $v_{o1(d)}$ can be written

$$\begin{aligned} v_{o1(d)} &= \frac{i_{c1(sc)}}{v_{tb1(d)}} \times \frac{v_{o1(d)}}{i_{c1(sc)}} \times v_{tb1(d)} = G_{m(d)} \times (-r_{ic} \parallel R_{tc}) \times \frac{v_{i(d)}}{2} \\ &= \frac{1}{2} G_{m(d)} \times (-r_{ic} \parallel R_{tc}) (v_{tb1} - v_{tb2}) \end{aligned} \quad (61)$$

By symmetry $v_{o2(d)} = -v_{o1(d)}$.

With $v_{i(d)} = 0$, the effects of $v_{tb1} = v_{tb2} = v_{i(cm)}$ are to cause the emitter currents in Q_1 and Q_2 to change by the same amounts. If R_Q is replaced by two parallel resistors of value $2R_Q$, it follows by symmetry that the circuit can be separated into two common-emitter stages each with $R_{te(cm)} = R_E + 2R_Q$. In this case, $v_{o1(cm)}$ can be written

$$\begin{aligned} v_{o1(cm)} &= \frac{i_{c1(sc)}}{v_{tb1(cm)}} \times \frac{v_{o1(cm)}}{i_{c1(sc)}} v_{tb1(cm)} = G_{m(cm)} (-r_{ic} \parallel R_{tc}) v_{i(cm)} \\ &= G_{m(cm)} \times (-r_{ic} \parallel R_{tc}) \left(\frac{v_{tb1} + v_{tb2}}{2} \right) \end{aligned} \quad (62)$$

By symmetry $v_{o2(cm)} = v_{o1(cm)}$. Note that the collector resistance r_{ic} is the same for both the differential and common-mode solutions.

We define the differential gain A_v and the common-mode gain A_{cm} as follows:

$$A_d = \frac{v_{o1}}{v_{i(d)}} = -\frac{v_{o2}}{v_{i(d)}} = \frac{1}{2} G_{m(d)} \times (-r_{ic} \parallel R_{tc}) \quad (63)$$

$$A_{cm} = \frac{v_{o1}}{v_{i(cm)}} = -\frac{v_{o2}}{v_{i(cm)}} = G_{m(cm)} (-r_{ic} || R_{te}) \quad (64)$$

By superposition, the total solutions for the output voltages are given by

$$\begin{aligned} v_{o1} &= A_d v_{i(d)} + A_{cm} v_{i(cm)} = A_d (v_{tb1} - v_{tb2}) + A_{cm} \left(\frac{v_{tb1} + v_{tb2}}{2} \right) \\ &= \left(A_d + \frac{A_{cm}}{2} \right) v_{i1} + \left(A_d + \frac{A_{cm}}{2} \right) v_{i2} \end{aligned} \quad (65)$$

$$\begin{aligned} v_{o2} &= -A_d v_{i(d)} + A_{cm} v_{i(cm)} = -A_d (v_{tb1} - v_{tb2}) + A_{cm} \left(\frac{v_{tb1} + v_{tb2}}{2} \right) \\ &= \left(-A_d + \frac{A_{cm}}{2} \right) v_{i1} + \left(-A_d + \frac{A_{cm}}{2} \right) v_{i2} \end{aligned} \quad (66)$$

Although they may look different, these solutions are identical to the solutions obtained above.

The common-mode rejection ratio $CMRR$ is defined by

$$CMRR = \frac{A_d}{A_{cm}} = \frac{G_{m(d)}}{G_{m(cm)}} = \frac{\frac{1}{2} \frac{\alpha}{r_{ie} + R_E}}{\frac{\alpha}{r_{ie} + R_E + 2R_Q}} = \frac{1}{2} + \frac{R_Q}{r_{ie} + R_E} \quad (67)$$

This is often expressed in dB with the relation $CMRR_{dB} = 20 \log (CMRR)$. For a perfect differential amplifier, $R_Q = \infty$ and thus $CMRR = \infty$. If the large r_0 approximations are not used, the $CMRR$ becomes much more difficult to solve for and will not be covered here.

Because R_{te} is different for the differential and common-mode circuits, G_m and r_{ib} are different. However, the total solution $v_{o1} = v_{o1(d)} + v_{o1(cm)}$ is the same as that given by Eq. (55), and similarly for v_{o2} . Note that r_{ic} is the same for both solutions and is calculated with $R_{te} = R_E + R_Q || (R_E + r_{ie})$. The small-signal base currents can be written $i_{b1} = v_{i(cm)}/r_{ib(cm)} + v_{i(d)}/r_{ib(d)}$ and $i_{b2} = v_{i(cm)}/r_{ib(cm)} - v_{i(d)}/r_{ib(d)}$. If $R_Q \rightarrow \infty$, the common-mode gain approaches zero when the r_0 approximations are used, which is the case here. In this case, the differential solutions can be used for the total solutions. If $R_Q \gg R_E + r_{ie}$, the common-mode solutions are often approximated by zero to simplify working differential amplifier problems.

Small-Signal High-Frequency Models

Figure 18 shows the hybrid- π and T models for the BJT with the base-spreading resistance r_x , the base-emitter capacitance c_π , and the base-collector capacitance c_μ added. The capacitor c_{cs} is the collector-substrate capacitance which is present in monolithic integrated-circuit devices but is omitted in discrete devices. These capacitors model charge storage in the device which affects its high-frequency performance. The capacitors are given by

$$c_\pi = c_{je} + \frac{\tau_F I_C}{V_T} \quad (68)$$

$$c_\mu = \frac{c_{jc}}{[1 + V_{CB}/\phi_C]^{m_c}} \quad (69)$$

$$c_{cs} = \frac{c_{jcs}}{[1 + V_{CS}/\phi_C]^{m_c}} \quad (70)$$

where I_C is the dc collector current, V_{CB} is the dc collector-base voltage, V_{CS} is the dc collector-substrate voltage, c_{je} is the zero-bias junction capacitance of the base-emitter junction, τ_F is

the forward transit time of the base-emitter junction, c_{jc} is the zero-bias junction capacitance of the base-collector junction, c_{jcs} is the zero-bias collector-substrate capacitance, ϕ_C is the built-in potential, and m_c is the junction exponential factor. For integrated circuit lateral pnp transistors, c_{cs} is replaced with a capacitor c_{bs} from base to substrate, i.e. from the B node to ground.

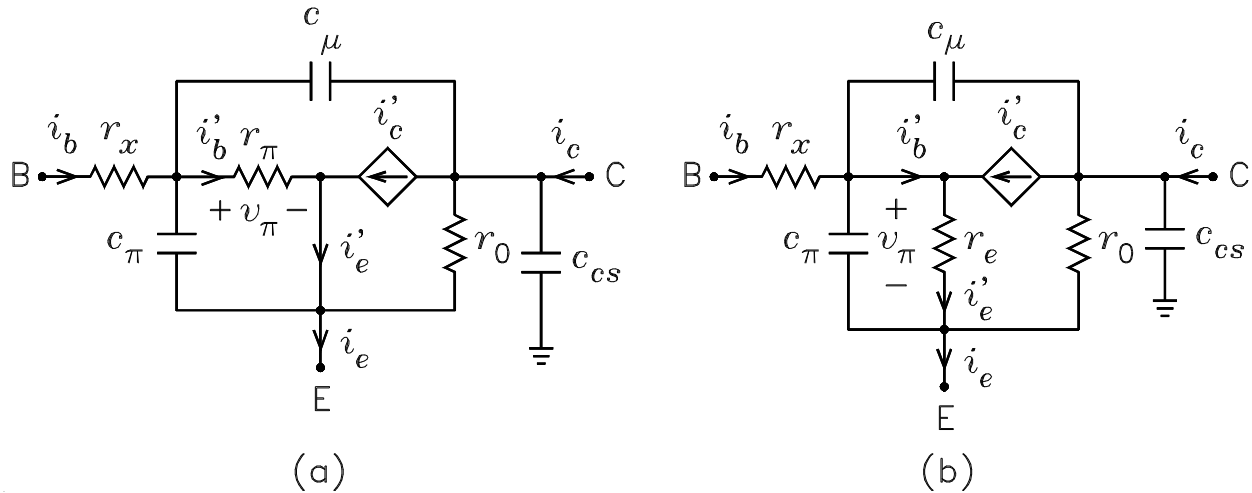

Figure 18: High-frequency small-signal models of the BJT. (a) Hybrid- π model. (b) T model.

In these models, the currents are related by

$$i'_c = g_m v_\pi = \beta i'_b = \alpha i'_e \quad (71)$$

These relations are the same as those in Eq. (24) with i_b replaced with i'_b .