

Complementary CC Amplifier

Figure 1 shows a complementary common-collector stage. This is commonly used as the final output stage in op amps and audio power amplifiers. Compared to a non-complementary CC amplifier, it can supply large positive and negative load currents with low power dissipation in the absence of a signal. The npn BJT supplies positive load current while the pnp BJT supplies negative load current.

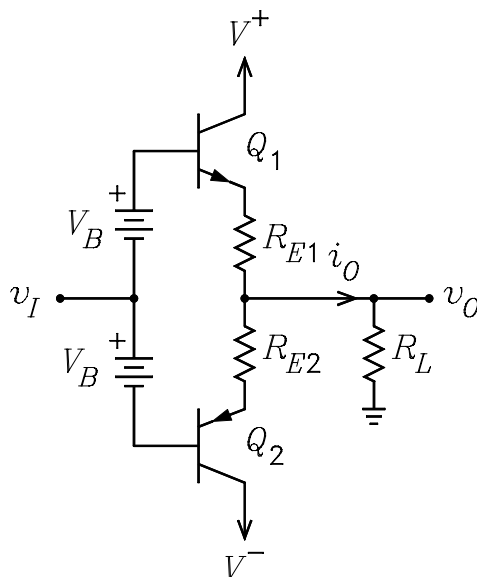

Figure 1: Complementary common-collector amplifier.

Let us first examine the performance of the circuit with $V_B = 0$. For $v_I = 0$, both transistors are cut off. In order to obtain a positive output voltage, v_I must be increased until Q_1 turns on. Denote the turn-on voltage for Q_1 by V_γ . Similarly, denote the turn-on voltage for Q_2 by $-V_\gamma$. When $-V_\gamma < v_I < V_\gamma$, both transistors are off and there is very little output voltage. For $v_I > V_\gamma$, Q_1 turns on and v_O goes positive. For $v_I < -V_\gamma$, Q_2 turns on and v_O goes negative. The plot of v_O versus v_I would resemble curve *a* in Fig. 2. A sine wave applied to the circuit would exhibit distortion in the crossover range for $-V_\gamma < v_I < V_\gamma$ as is illustrated by curve *a* in Fig. 3. The distortion in the waveform is called crossover distortion or center clipping.

For $V_B > 0$, a positive bias voltage is applied to the base of Q_1 and a negative bias voltage is applied to the base of Q_2 . As V_B is increased, both transistors turn on and emitter currents flow that are given by

$$I_{E1} = I_{E2} = \frac{2V_B - V_{BE1} - V_{BE2}}{R_{E1} + R_{E2}}$$

The bias voltage causes the portion of curve *a* in Fig. 2 for $v_I > 0$ to be shifted to the left and the portion for $v_I < 0$ to be shifted to the right. The effective sum curve changes into approximately a straight line as shown in curve *b* in Fig. 2. This eliminates the crossover distortion in the output waveform in shown by curve *b* in Fig. 3.

Once the transistors are turned on, the emitter currents are extremely sensitive to the value of V_B . To reduce this sensitivity, resistors are often used in series with the emitters as shown in Fig. 1. If an excessive emitter current flows, the voltage drops across R_{E1} and R_{E2} cause V_{BE1} and V_{BE2} to decrease, causing the current to decrease. For minimum power dissipation in these resistors, their value must be much smaller than that of R_L . In the design of op amps, the emitter resistors are usually omitted. In this case, the value

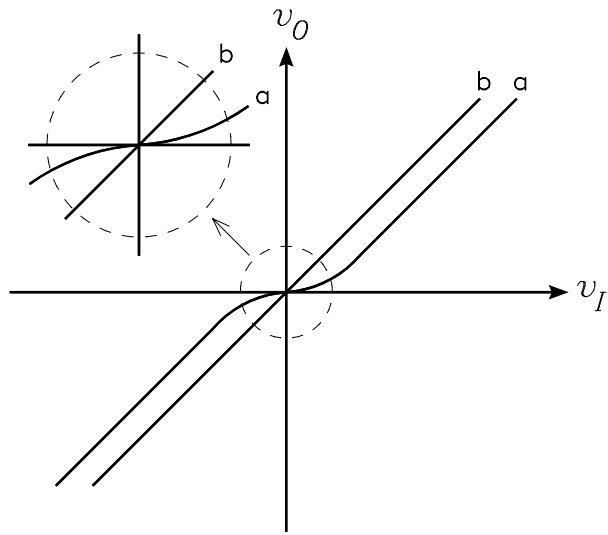

Figure 2: Plots of v_O versus v_I . Curve a - $V_B = 0$. Curve b - V_B adjusted to eliminate the deadband region.

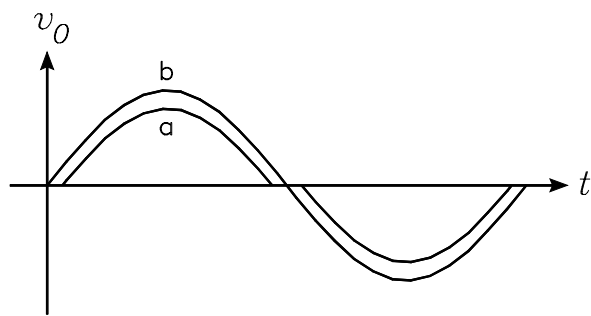

Figure 3: Sine wave (a) with and (b) without crossover distortion.

of V_B is chosen to bias the transistors just below cutoff. Although a small amount of crossover remains, it is minimized by the negative feedback that is used in the application of the op amps.

The circuit that is commonly used to bias a common-collector stage is the V_{BE} multiplier. Fig. 4 shows a simple V_{BE} multiplier consisting of transistor Q_3 connected between the bases of Q_1 and Q_2 . The voltage across the multiplier is given by

$$V_B = I_1 R_1 + V_{BE3}$$

If the base current in Q_3 is small compared to I_1 , we can write $I_1 = V_{BE3}/R_2$. When this is substituted into the equation for V_B , we obtain

$$V_B = \frac{V_{BE3}}{R_2} R_1 + V_{BE3} = V_{BE3} \left(1 + \frac{R_1}{R_2} \right)$$

It follows that the voltage V_B can be set by proper choice of the ratio R_1/R_2 .

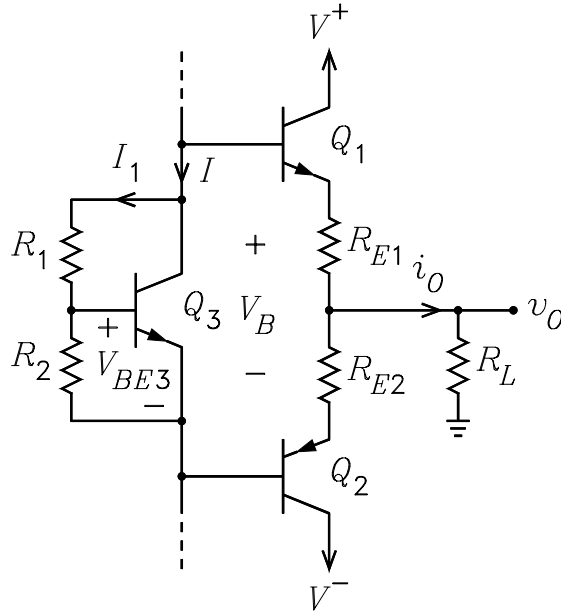

Figure 4: Complementary common-collector amplifier with a V_{BE} multiplier bias circuit.

The exact equation for V_B can be obtained by writing a node equation at the base node of Q_3 . The equation is

$$\frac{V_B - V_{BE}}{R_1} = \frac{V_{BE}}{R_2} + \frac{1}{\beta} \left(I - \frac{V_B - V_{BE}}{R_1} \right)$$

This can be solved for V_B to obtain

$$V_B = V_{BE} \left(\alpha + \frac{R_1}{R_2} \right) + \frac{I R_1}{1 + \beta}$$

where $\alpha = \beta / (1 + \beta)$ has been used. This agrees with the approximate solution above if β is large and $I R_1 \ll 1 + \beta$.