

The Common-Base Amplifier

Basic Circuit

Fig. 1 shows the circuit diagram of a single stage common-base amplifier. The object is to solve for the small-signal voltage gain, input resistance, and output resistance.

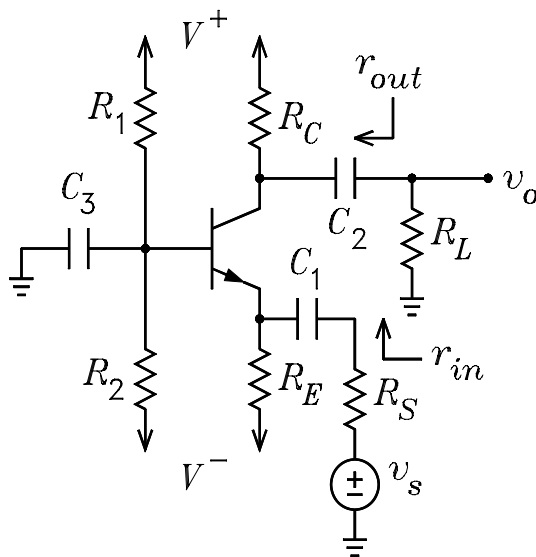

Figure 1: Common-base amplifier.

DC Solution

(a) Replace the capacitors with open circuits. Look out of the 3 BJT terminals and make Thévenin equivalent circuits as shown in Fig. 2.

$$V_{BB} = \frac{V^+R_2 + V^-R_1}{R_1 + R_2} \quad R_{BB} = R_1 || R_2$$

$$V_{EE} = V^- \quad R_{EE} = R_E \quad V_{CC} = V^+ \quad R_{CC} = R_C$$

(b) Make an “educated guess” for V_{BE} . Write the loop equation between the V_{BB} and the V_{EE} nodes. To solve for I_C , this equation is

$$V_{BB} - V_{EE} = I_B R_{BB} + V_{BE} + I_E R_{EE} = \frac{I_C}{\beta} R_{BB} + V_{BE} + \frac{I_C}{\alpha} R_{EE}$$

(c) Solve the loop equation for the currents.

$$I_C = \alpha I_E = \beta I_B = \frac{V_{BB} - V_{EE} - V_{BE}}{R_{BB}/\beta + R_{EE}/\alpha}$$

(d) Verify that $V_{CB} > 0$ for the active mode.

$$V_{CB} = V_C - V_B = (V_{CC} - I_C R_{CC}) - (V_{BB} - I_B R_{BB}) = V_{CC} - V_{BB} - I_C (R_{CC} - R_{BB}/\beta)$$

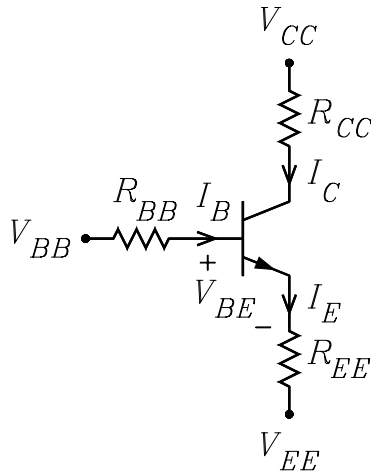

Figure 2: DC bias circuit.

Small-Signal or AC Solutions

(a) Redraw the circuit with $V^+ = V^- = 0$ and all capacitors replaced with short circuits as shown in Fig. 3.

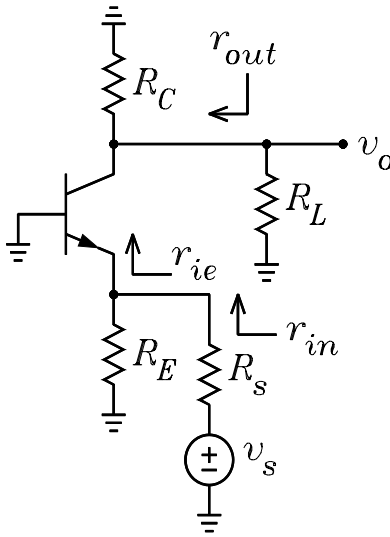

Figure 3: Signal circuit.

(b) Calculate g_m , r_π , r_e , and r_0 from the DC solution..

$$g_m = \frac{I_C}{V_T} \quad r_\pi = \frac{V_T}{I_B} \quad r_e = \frac{V_T}{I_E} \quad r_0 = \frac{V_A + V_{CE}}{I_C}$$

(c) Replace the circuits looking out of the base and emitter with Thévenin equivalent circuits as shown in Fig. 4.

$$v_{tb} = 0 \quad R_{tb} = 0 \quad v_{te} = v_s \frac{R_E}{R_s + R_E} \quad R_{te} = R_s || R_E$$

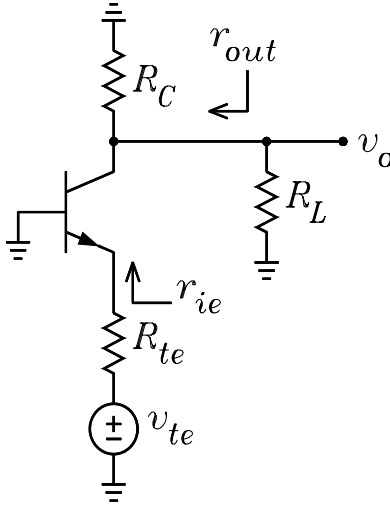

Figure 4: Signal circuit with Thévenin emitter circuit.

Exact Solution

(a) Replace the BJT in Fig. 4 with the Thévenin emitter circuit and the Norton collector circuit as shown in Fig. 5.

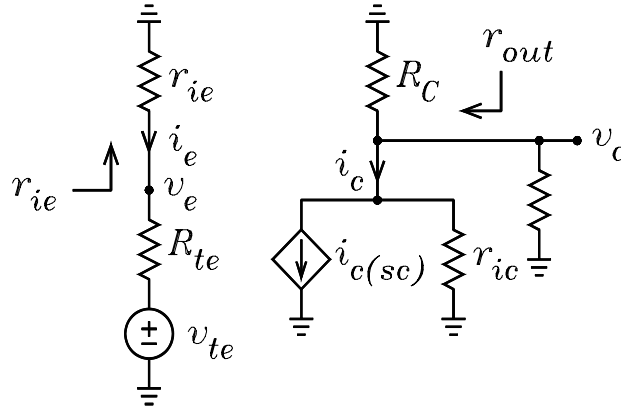

Figure 5: Emitter and collector equivalent circuits.

(b) Solve for $i_{c(sc)}$.

$$i_{c(sc)} = -G_{me}v_{te} = -G_{me}v_s \frac{R_E}{R_s + R_E}$$

$$G_{me} = \frac{1}{R_{te} + r'_e \parallel r_0} \frac{\alpha r_0 + r'_e}{r_0 + r'_e} \quad r'_e = \frac{r_x}{1 + \beta} + r_e$$

(c) Solve for v_o .

$$v_o = -i_{c(sc)} r_{ic} \parallel R_C \parallel R_L = G_{me} v_s \frac{R_E}{R_s + R_E} r_{ic} \parallel R_C \parallel R_L$$

$$r_{ic} = \frac{r_0 + r'_e \parallel R_{te}}{1 - \alpha R_{te} / (r'_e + R_{te})}$$

(d) Solve for the voltage gain.

$$A_v = \frac{v_o}{v_s} = \frac{R_E}{R_s + R_E} G_{me} r_{ic} \| R_C \| R_L$$

(e) Solve for r_{in} .

$$r_{in} = R_1 \| R_2 \| r_{ie} \quad r_{ie} = r'_e \frac{r_0 + R_{tc}}{r'_e + r_0 + R_{tc}/(1 + \beta)}$$

(f) Solve for r_{out} .

$$r_{out} = r_{ic} \| R_C$$

Example 1 For the CB amplifier in Fig. 1, it is given that $R_s = 100 \Omega$, $R_1 = 120 \text{ k}\Omega$, $R_2 = 100 \text{ k}\Omega$, $R_C = 4.3 \text{ k}\Omega$, $R_E = 5.6 \text{ k}\Omega$, $R_3 = 100 \Omega$, $R_L = 20 \text{ k}\Omega$, $V^+ = 15 \text{ V}$, $V^- = -15 \text{ V}$, $V_{BE} = 0.65 \text{ V}$, $\beta = 99$, $\alpha = 0.99$, $r_x = 20 \Omega$, $V_A = 100 \text{ V}$ and $V_T = 0.025 \text{ V}$. Solve for A_v , r_{in} , and r_{out} .

Solution. Because the dc bias circuit is the same as for the common-emitter amplifier example, the dc bias values, r_e , g_m , r_π , and r_0 are the same.

In the signal circuit, the Thévenin voltage and resistance seen looking out of the emitter are given by

$$v_{te} = \frac{R_E}{R_s + R_E} v_s = 0.9825 v_s \quad R_{te} = R_s \| R_E = 98.25 \Omega$$

The Thévenin resistances seen looking out of the base and the collector are

$$R_{tb} = 0 \quad R_{tc} = R_C \| R_L = 3.539 \text{ k}\Omega$$

Next, we calculate r'_e , G_{me} , r_{ic} , and r_{ie} .

$$r'_e = \frac{R_{tb} + r_x}{1 + \beta} + r_e = 12.03 \Omega \quad G_{me} = \frac{1}{R_{te} + r'_e \| r_0} \frac{\alpha r_0 + r'_e}{r_0 + r'_e} = \frac{1}{111.4} \text{ S}$$

$$r_{ic} = \frac{r_0 + r'_e \| R_{tc}}{1 - \alpha R_{te}/(r'_e + R_{te})} = 442.3 \text{ k}\Omega \quad r_{ie} = r'_e \frac{r_0 + R_{tc}}{r'_e + r_0 + R_{tc}/(1 + \beta)} = 12.83 \Omega$$

The output voltage is given by

$$v_o = G_{me} (r_{ic} \| R_{tc}) v_{te} = G_{me} (r_{ic} \| R_{tc}) \frac{R_E}{R_s + R_E} v_s = 30.97 v_s$$

Thus the voltage gain is

$$A_v = 30.97$$

The input and output resistances are

$$r_{in} = R_1 \| R_2 \| r_{ib} = 12.81 \Omega \quad r_{out} = r_{ic} \| R_C = 4.259 \text{ k}\Omega$$

Approximate Solutions

These solutions assume that $r_0 = \infty$ except in calculating r_{ic} . In this case, $i_{c(sc)} = i'_c = \alpha i'_e = \beta i_b$.

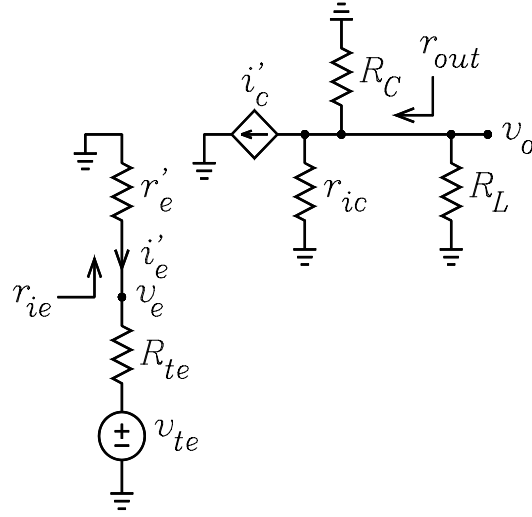

Figure 6: Simplified T model circuit.

Simplified T Model Solution

(a) After making the Thévenin equivalent circuits looking out of the base and emitter, replace the BJT with the simplified T model as shown in Fig. 6.

(b) Solve for i'_c and r_{ic} .

$$0 - v_{te} = i'_e (r'_e + R_{te}) = \frac{i'_c}{\alpha} (r'_e + R_{te}) \implies i'_c = -v_{te} \frac{\alpha}{r'_e + R_{te}}$$

$$r_{ic} = \frac{r_0 + r'_e \parallel R_{te}}{1 - \alpha R_{te} / (r'_e + R_{te})}$$

(c) Solve for v_o .

$$v_o = -i'_c r_{ic} \parallel R_C \parallel R_L = v_{te} \frac{\alpha}{r'_e + R_{te}} r_{ic} \parallel R_C \parallel R_L = v_s \frac{R_E}{R_s + R_E} \frac{\alpha}{r'_e + R_{te}} r_{ic} \parallel R_C \parallel R_L$$

(d) Solve for the voltage gain.

$$A_v = \frac{v_o}{v_s} = \frac{R_s}{R_s + R_E} \frac{\alpha}{r'_e + R_{te}} r_{ic} \parallel R_C \parallel R_L$$

(e) Solve for r_{ie} and r_{in} .

$$0 - v_e = i'_e r'_e \implies i'_e = -\frac{v_e}{r'_e}$$

$$r_{ie} = \frac{v_e}{-i'_e} = r'_e$$

$$r_{in} = r'_e \parallel R_E$$

(f) Solve for r_{out} .

$$r_{out} = r_{ic} \parallel R_C$$

Example 2 For Example 1, use the simplified T-model solutions to calculate the values of A_v , r_{in} , and r_{out} .

$$A_v = 0.9825 \times (8.978 \times 10^{-3}) \times (3.511 \times 10^3) = 30.97$$

$$r_{in} = 12 \Omega \quad r_{out} = 4.259 \text{ k}\Omega$$

π Model Solution

(a) After making the Thévenin equivalent circuits looking out of the base and emitter, replace the BJT with the π model as shown in Fig. 7.

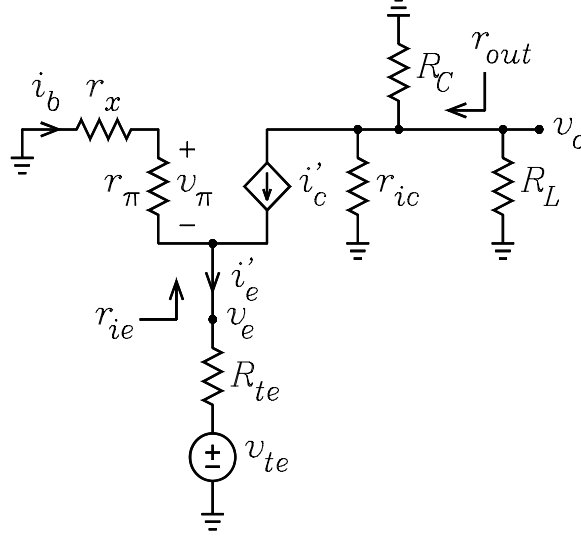

Figure 7: Hybrid- π model circuit.

(b) Solve for i'_c and r_{ic} .

$$0 - v_{te} = i_b r_x + v_\pi + i'_e R_{te} = \frac{i'_c}{\beta} r_x + \frac{i'_c}{g_m} + \frac{i'_c}{\alpha} R_{te} \implies i'_c = \frac{-v_{te}}{\frac{r_x}{\beta} + \frac{1}{g_m} + \frac{R_{te}}{\alpha}}$$

$$r_{ic} = \frac{r_0 + r'_e \parallel R_{te}}{1 - \alpha R_{te} / (r'_e + R_{te})}$$

(c) Solve for v_o .

$$v_o = -i'_c r_{ic} \parallel R_C \parallel R_L = \frac{v_{te}}{\frac{r_x}{\beta} + \frac{1}{g_m} + \frac{R_{te}}{\alpha}} r_{ic} \parallel R_C \parallel R_L = v_s \frac{R_E}{R_s + R_E} \frac{1}{\frac{r_x}{\beta} + \frac{1}{g_m} + \frac{R_{te}}{\alpha}} r_{ic} \parallel R_C \parallel R_L$$

(d) Solve for the voltage gain.

$$A_v = \frac{v_o}{v_s} = \frac{R_E}{R_s + R_E} \frac{1}{\frac{r_x}{\beta} + \frac{1}{g_m} + \frac{R_{te}}{\alpha}} r_{ic} \parallel R_C \parallel R_L$$

(e) Solve for r_{out} .

$$r_{out} = r_{ic} \parallel R_C$$

(f) Solve for r_{ie} and r_{in} .

$$0 - v_e = i_b (r_x + r_\pi) = \frac{i'_e}{1 + \beta} (r_x + r_\pi) \implies i'_e = -v_e \frac{1 + \beta}{r_x + r_\pi}$$

$$r_{ie} = \frac{v_e}{-i'_e} = \frac{r_x + r_\pi}{1 + \beta}$$

$$r_{in} = r_{ie} \parallel R_E$$

Example 3 For Example 1, use the π -model solutions to calculate the values of A_v , r_{in} , and r_{out} .

$$A_v = 0.9825 \times (8.978 \times 10^{-3}) \times (3.539 \times 10^3) = 30.97$$

$$r_{in} = 12 \Omega \quad r_{out} = 4.259 \text{ k}\Omega$$

T Model Solution

(a) After making the Thévenin equivalent circuits looking out of the base and emitter, replace the BJT with the T model as shown in Fig.??.

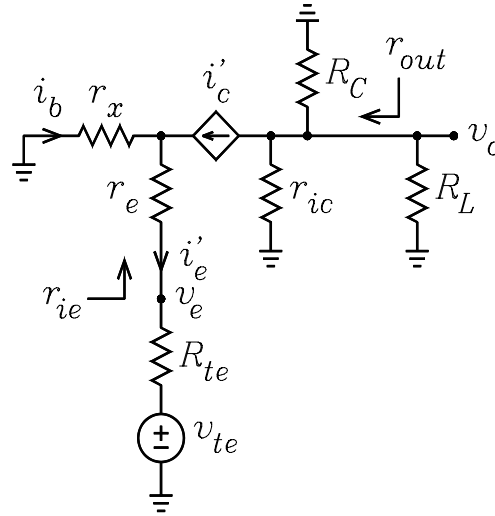

Figure 8: T model circuit.

(b) Solve for i'_c and r_{ic} .

$$0 - v_{te} = i_b r_x + i'_e (r_e + R_{te}) = \frac{i'_c}{\beta} r_x + \frac{i'_c}{\alpha} (r_e + R_{te}) \implies i'_c = \frac{-v_{te}}{\frac{r_x}{\beta} + \frac{r_e + R_{te}}{\alpha}}$$

$$r_{ic} = \frac{r_0 + r'_e \parallel R_{te}}{1 - \alpha R_{te} / (r'_e + R_{te})}$$

(c) Solve for v_o .

$$v_o = -i'_c r_{ic} \parallel R_C \parallel R_L = \frac{v_{te}}{\frac{r_x}{\beta} + \frac{r_e + R_{te}}{\alpha}} r_{ic} \parallel R_C \parallel R_L = v_s \frac{R_E}{R_s + R_E} \frac{1}{\frac{r_x}{\beta} + \frac{r_e + R_{te}}{\alpha}} r_{ic} \parallel R_C \parallel R_L$$

(d) Solve for the voltage gain.

$$A_v = \frac{v_o}{v_s} = \frac{R_E}{R_s + R_E} \frac{1}{\frac{r_x}{\beta} + \frac{r_e + R_{te}}{\alpha}} r_{ic} \| R_C \| R_L$$

(e) Solve for r_{ie} and r_{in} .

$$0 - v_e = i_b r_x + i'_e r_e = \frac{i'_e}{1 + \beta} r_x + i'_e r_e = i'_e \left(\frac{r_x}{1 + \beta} + r_e \right) \implies i'_e = \frac{-v_e}{\frac{r_x}{1 + \beta} + r_e}$$

$$r_{ie} = \frac{v_e}{-i'_e} = \frac{r_x}{1 + \beta} + r_e$$

$$r_{in} = R_E \| r_{ie}$$

(f) Solve for r_{out} .

$$r_{out} = r_{ic} \| R_C$$

Example 4 For Example 1, use the T-model solutions to calculate the values of A_v , r_{in} , and r_{out} .

$$A_v = 0.9825 \times (8.978 \times 10^{-3}) \times (3.539 \times 10^3) = 30.97$$

$$r_{in} = 12 \Omega \quad r_{out} = 4.259 \text{ k}\Omega$$