

Current Mirrors

Basic Current Mirror

Current mirrors are basic building blocks of analog design. Fig. 1(a) shows the basic npn current mirror. For its analysis, we assume identical transistors and neglect the Early effect, i.e. we assume $V_A \rightarrow \infty$. This makes the saturation current I_S and current gain β independent of the collector-base voltage V_{CB} . The input current to the mirror is labeled I_{REF} . This current might come from a resistor connected to the positive rail or a current source realized with a transistor or another current mirror. The emitters of the two transistors are shown connected to ground. These can be connected to a dc voltage, e.g. the negative supply rail.

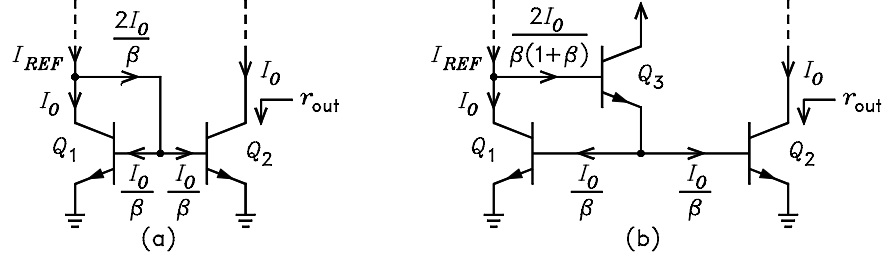

Figure 1: (a) Basic mirror. (b) Mirror with base current compensation.

The simplest way to solve for the output current is to sum the currents at the node where I_{REF} enters the mirror. Because the two transistors have their base-emitter junctions in parallel, it follows that both must have the same currents. Thus, we can write the equation

$$I_{REF} = I_O + \frac{2I_O}{\beta}$$

Solution for I_O yields

$$I_O = \frac{I_{REF}}{1 + 2/\beta}$$

Because the Early effect has been neglected in solving for I_O , the output resistance is infinite. If we include the Early effect and assume that it has negligible effect in the solution for I_O , the output resistance is given by

$$r_{out} = r_{o2} = \frac{V_{CB2} + V_A}{I_O}$$

For a more accurate analysis, we can include the Early effect in calculating the output current. If the transistors have the same parameters, we can write

$$I_{C1} = I_{S0} \exp\left(\frac{V_{BE}}{V_T}\right) \quad I_{B1} = \frac{I_{C1}}{\beta_0}$$

$$I_O = I_{S0} \left(1 + \frac{V_{CB2}}{V_A}\right) \exp\left(\frac{V_{BE}}{V_T}\right) \quad I_{B2} = \frac{I_O}{\beta_0 (1 + V_{CB2}/V_A)}$$

By taking the ratio of I_O to I_{C1} , we obtain

$$I_O = \left(1 + \frac{V_{CB2}}{V_A}\right) I_{C1}$$

Summing currents at the node where I_{REF} enters the circuit yields

$$I_{REF} = I_{C1} + \frac{I_{C1}}{\beta_0} + \frac{I_O}{\beta_0(1 + V_{CB2}/V_A)} = I_{C1} + \frac{2I_{C1}}{\beta_0}$$

Thus I_{C1} is given by

$$I_{C1} = \frac{I_{REF}}{1 + 2/\beta_0}$$

It follows that I_O is given by

$$I_O = \left(1 + \frac{V_{CB2}}{V_A}\right) I_{C1} = \frac{I_{REF}(1 + V_{CB2}/V_A)}{1 + 2/\beta_0}$$

The output resistance is given above.

Note that the effect of a finite β is to reduce I_O but the effect of the Early effect is to increase it. Because of the Early effect, the output current is commonly greater than the input current. One way of obtaining a better match between the input and output currents is to use series emitter resistors on the transistors. If the current in one transistor increases, it causes the voltage across its emitter resistor to increase, which causes a decrease in its base-emitter voltage. This causes the current to decrease, thus causing the two transistors to have more equal currents. A typical value for the emitter resistors is 100Ω . With these resistors, R_{te2} is no longer zero so that the output resistance is increased. It is given by $r_{out} = r_{ic2}$ which can be much greater than r_{02} .

Current Mirror with Base Current Compensation

Figure 1(b) shows the basic current mirror with a third transistor added. The collector of Q_3 must be connected to a positive reference voltage, e.g. the positive supply rail, which biases it in the active mode. If we neglect the Early effect and assume all transistors are identical, we can write

$$I_{REF} = I_O + \frac{2I_O}{\beta(1 + \beta)}$$

Solution for I_O yields

$$I_O = \frac{I_{REF}}{1 + 2/[\beta(1 + \beta)]}$$

For a non-infinite Early voltage and $V_{CB1} = V_{BE3} \ll V_A$, it can be shown that the output current is given by

$$I_O = \frac{I_{REF}(1 + V_{CB2}/V_A)}{1 + 2/[\beta_0(1 + \beta_3)]}$$

where

$$\beta_3 = \beta_0 \left(1 + \frac{V_{CB3}}{V_A}\right)$$

The Wilson Current Mirror

A Wilson current mirror is shown in Fig. 2(a). We neglect the Early effect in the analysis and assume the transistors to have identical parameters. The emitter current in Q_3 is I_O/α . This current is the input to a basic current mirror consisting of Q_1 and Q_2 . It is mirrored into the collector of Q_1 by dividing by $(1 + 2/\beta)$. At the node where I_{REF} enters the mirror, we can write

$$I_{REF} = \frac{I_O/\alpha}{1 + 2/\beta} + \frac{I_O}{\beta} = I_O \frac{1 + \beta}{2 + \beta} + \frac{I_O}{\beta}$$

Solution for I_O yields

$$I_O = \frac{I_{REF}}{\frac{1+\beta}{2+\beta} + \frac{1}{\beta}}$$

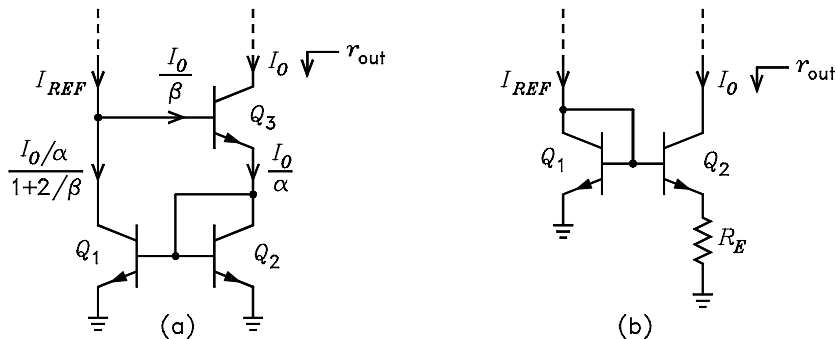

Figure 2: (a) Wilson mirror. (b) Low-level mirror.

The advantage of the Wilson mirror over the current mirrors examined above is that it has a much higher output resistance. This is caused by two positive feedback effects. To see how this occurs, suppose a test current source is connected between the mirror output and ground. If the source delivers current to the output node, the voltage increases. This causes a current to flow through r_{o3} , causing the emitter voltage of Q_3 and the base voltage of Q_1 to increase. The increase in voltage at the emitter of Q_3 causes its collector voltage to increase because Q_3 is a common-base stage for an emitter input. The increase in voltage at the base of Q_1 causes the collector voltage of Q_1 and the base voltage of Q_3 to decrease because Q_1 is a common-emitter stage for a base input. The decrease in voltage at the base of Q_3 causes its collector voltage to increase because Q_3 is a common-emitter stage for a base input. Thus there are two positive feedback effects which cause the collector voltage of Q_3 to increase to a larger value. Because r_{out} is the ratio of the collector voltage of Q_3 to the current in the test source, it follows that the output resistance is increased.

Low-Level Current Mirror

The circuit shown in Fig. 2(b) is a low-level current mirror. It can be used when it is desired to have a much lower output current than input current. For the analysis, we neglect the Early effect, assume identical transistors, and assume that $\beta \rightarrow \infty$. We can write

$$I_{REF} = I_S \exp\left(\frac{V_{BE1}}{V_T}\right) \quad I_O = I_S \exp\left(\frac{V_{BE1} - I_O R_E}{V_T}\right)$$

By taking ratios, we obtain

$$\frac{I_{REF}}{I_O} = \exp\left(\frac{I_O R_E}{V_T}\right)$$

This equation cannot be solved for I_O . However, if I_{REF} and I_O are specified, it can be solved for R_E to obtain

$$R_E = \frac{V_T}{I_O} \ln\left(\frac{I_{REF}}{I_O}\right)$$

As an example, suppose $I_{REF} = 1$ mA, $V_T = 25$ mV, and $I_O = 50$ μ A. It follows from this equation that $R_E = 1498$ Ω . The effect of this large a value of R_E on r_{out} is to make it greater than r_{o2} . To calculate r_{out} , we must know the small-signal Thévenin resistance R_{tb2} looking out of the base of Q_2 . Q_1 is a bjt connected as a diode and exhibits a small-signal resistance $r_{o1} \parallel [r_{x1}/(1 + \beta_1) + V_T/I_{E1}] \simeq V_T/I_{E1} = 25$ Ω . This is in parallel with the small-signal resistance looking up into the I_{REF} source. Thus an upper bound on R_{tb2} is 25 Ω . Let us assume $r_{o2} = 40$ k Ω , $r_{x2} = 0$, $\alpha_2 = 0.995$, and $\beta_2 = 199$. It follows that $r_{ie2} = R_{tb2}/(1 + \beta) + \alpha V_T/I_{C2} = 497.6$ Ω . Thus r_{out} is given by

$$r_{out} = r_{ie2} = \frac{40\text{k} + 497.6 \parallel 1498}{1 - 0.995 \times 1498 / (497.6 + 1498)} = 159.5 \text{ k}\Omega$$

This is larger than r_{o2} by a factor of almost 4.

The Transconductance Op Amp

An example application of the current mirror is the transconductance op amp. The circuit is shown in Fig. 3. The circuit consists of an input diff amp and four Wilson current mirrors. For the analysis, we assume $\beta \rightarrow \infty$ and $V_A \rightarrow \infty$ for each bjt so that the output current from each mirror is equal to the input current. We assume that I_{ABC} splits equally between the emitters of Q_1 and Q_2 . Thus the total currents in Q_1 and Q_2 , respectively, are given by

$$i_{C1} = \frac{I_{ABC}}{2} + i_{c1} \quad i_{C2} = \frac{I_{ABC}}{2} + i_{c2} = \frac{I_{ABC}}{2} - i_{c1}$$

The latter expression for i_{C2} follows because $i_{c1} + i_{c2} = 0$.

It follows from the mirrored currents that the output current is given by

$$i_o = 2i_{c1}$$

If we neglect base currents and the Early effect, $i_{c1} = i_{e1} = (v_{i1} - v_{i2})/2r_e$, where $r_e = 2V_T/I_{ABC}$. Thus i_o is given by

$$i_o = \frac{I_{ABC}}{2V_T} (v_{i1} - v_{i2})$$

Thus the transconductance gain is set by the current I_{ABC} . The gain can be varied by varying I_{ABC} . Because $I_{ABC} \geq 0$, the circuit operates as a two-quadrant multiplier. The circuit symbol for the transconductance op-amp is shown in Fig. 4.

An example application of the transconductance op amp is a circuit which generates an amplitude modulated signal. The circuit is shown in Fig. 5. Let v_i and I_{ABC} be given by

$$v_i = V_1 \sin \omega_c t \quad I_{ABC} = I_Q (1 + m \sin \omega_m t)$$

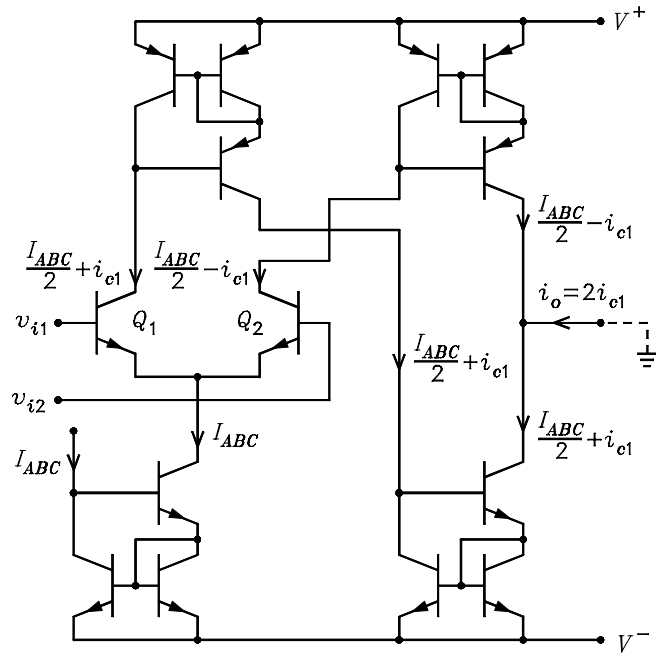

Figure 3: Transconductance op amp.

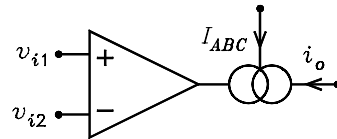

Figure 4: Circuit symbol for the transconductance op amp.

where ω_c is the carrier frequency, ω_m is the modulating frequency, and m is the modulation index which must satisfy $-1 < m < 1$. The current i_o is given by

$$i_o = \frac{I_{ABC}}{2V_T} \frac{v_i R_2}{R_1 + R_2}$$

If we assume that C_F is an open circuit at the operating frequencies, the current i_o must flow through R_F . Because the second op amp forces the voltage at its inverting input to be zero, the output voltage is given by

$$v_o = i_o R_F = \frac{I_{ABC}}{2V_T} \frac{v_i R_2}{R_1 + R_2} R_F = \frac{I_Q R_F}{2V_T} \frac{V_1 R_2}{R_1 + R_2} \sin \omega_c t (1 + m \sin \omega_m t)$$

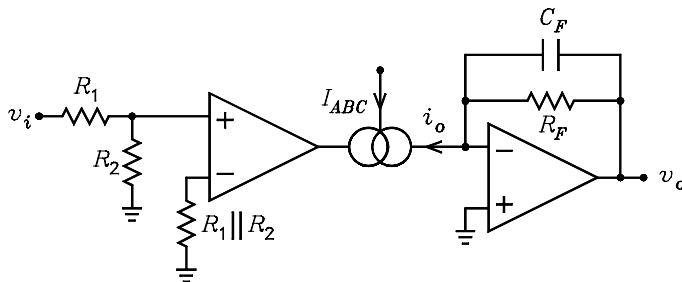

Figure 5: AM modulator.

An example waveform for v_o for the case $m = 0.6$ is shown in Fig. 6

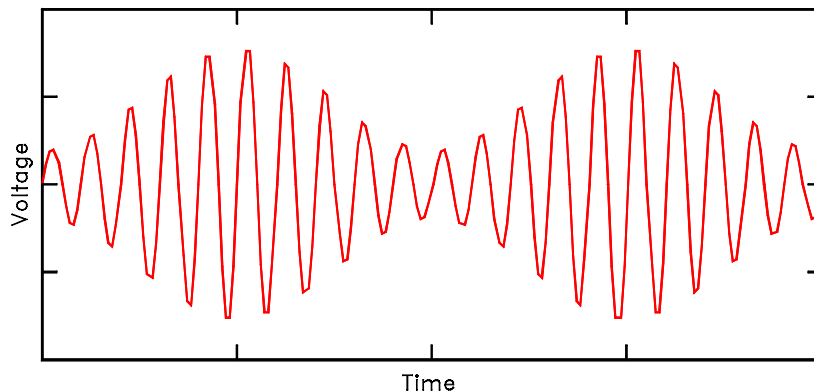

Figure 6: AM modulated waveform.

The purpose of the voltage divider formed by R_1 and R_2 at the input to the transconductance op amp is to attenuate the input signal so that it does not overload the input differential amplifier. The resistor $R_1 \parallel R_2$ is in series with the noninverting input so that both inputs to the differential amplifier see the same source resistance. Typically, R_1 and R_2 are chosen so that $R_1 \parallel R_2$ is no larger than about 100Ω . The capacitor C_F is necessary for proper high-frequency response. The capacitor must be chosen experimentally to prevent the gain of the circuit from peaking up at some high frequency where the circuit can oscillate. A method of determining the optimum value of C_F is to drive the circuit with a square wave for v_i and $m = 0$ so that $I_{ABC} = I_Q$, i.e. a dc current. The capacitor can be experimentally adjusted to minimize any ringing on the output waveform without degrading the bandwidth of the circuit.