

Cascode Amplifier Example - Spring 2002

$$R_P(x,y) := \frac{x \cdot y}{x + y}$$

Function for calculating parallel resistors.

$$R_1 := 390000 \quad R_2 := 200000 \quad R_3 := 56000 \quad R_4 := 100$$

$$R_C := 20000 \quad R_E := 4300 \quad R_S := 1000 \quad R_L := 10000$$

$$V_{\text{plus}} := 35 \quad V_{\text{minus}} := -30 \quad V_{BE} := 0.65 \quad V_T := 0.025 \quad \beta := 199 \quad \alpha := 0.995$$

$$r_x := 20 \quad r_o := 50000$$

$v_s := 1$ With $v_s = 1$, the voltage gain is equal to v_o , that is $A_v = v_o$.

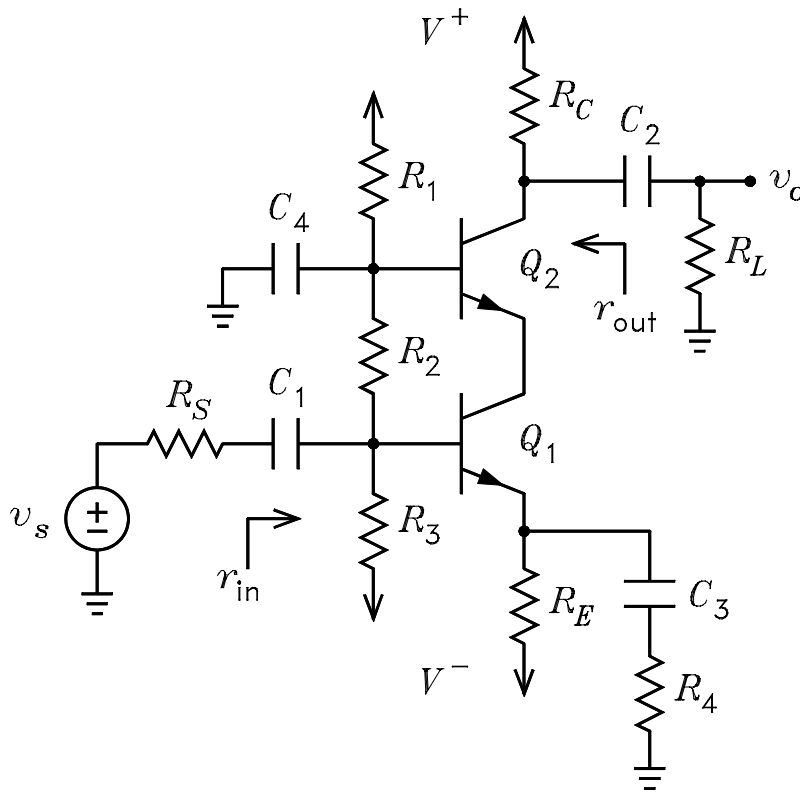

First, the dc bias solution

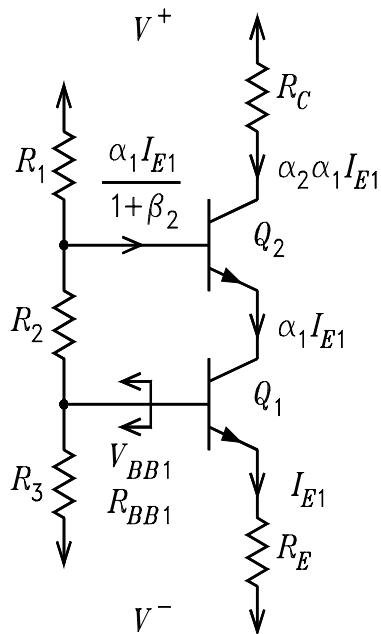

Solve for the Thevenin equivalent circuit looking out of the base of Q1

$$V_{BB1} = \frac{V_{plus} \cdot R_3 + V_{minus} \cdot (R_1 + R_2)}{R_1 + R_2 + R_3} - \frac{\alpha \cdot I_{E1}}{1 + \beta} \cdot \frac{R_1}{R_1 + R_2 + R_3} \cdot R_3$$

$$R_{BB1} := R_P(R_1 + R_2, R_3)$$

The bias loop equation is

$$V_{BB1} - V_{minus} = \frac{I_{E1}}{1 + \beta} R_{BB1} + V_{BE} + I_{E1} \cdot R_E$$

It follows that the solution for I_{E1} is

$$I_{E1} := \frac{\frac{V_{plus} \cdot R_3 + V_{minus} \cdot (R_1 + R_2)}{R_1 + R_2 + R_3} - V_{minus} - V_{BE}}{\frac{R_{BB1}}{1 + \beta} + R_E + \frac{\alpha}{1 + \beta} \cdot \frac{R_1 \cdot R_3}{R_1 + R_2 + R_3}}$$

$$I_{E1} = 1.0552 \cdot 10^{-3}$$

$$r_{e1} := \frac{V_T}{I_{E1}} \quad r_{e1} = 23.6922$$

$$I_{E2} := \alpha \cdot I_{E1} \quad I_{E2} = 1.0499 \cdot 10^{-3}$$

$$r_{e2} := \frac{V_T}{I_{E2}} \quad r_{e2} = 23.8113$$

Now, check to see that Q1 and Q2 are in the active mode

$$V_{B1} := V_{BE} + I_{E1} \cdot R_E + V_{\text{minus}} \quad V_{B1} = -24.8126$$

$$V_{B2} := \frac{V_{\text{plus}} \cdot (R_2 + R_3) + V_{\text{minus}} \cdot R_1}{R_1 + R_2 + R_3} - \frac{I_{E2}}{1 + \beta} \cdot R_P(R_1, R_2 + R_3) \quad V_{B2} = -5.0528$$

$$V_{C1} := V_{B2} - V_{BE} \quad V_{C1} = -5.7028$$

$$V_{CB1} := V_{C1} - V_{B1} \quad V_{CB1} = 19.1098 \quad \text{Thus active mode for Q1.}$$

$$V_{C2} := V_{\text{plus}} - \alpha \cdot I_{E2} \cdot R_C \quad V_{C2} = 14.1065$$

$$V_{CB2} := V_{C2} - V_{B2} \quad V_{CB2} = 19.1594 \quad \text{Thus active mode for Q2.}$$

Now for the ac solution

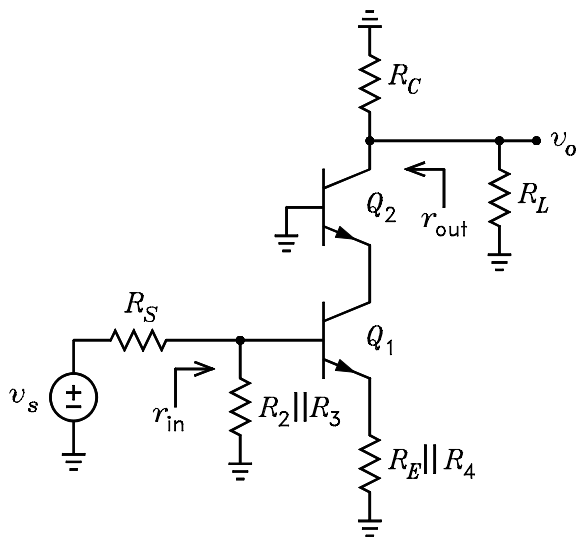

Make a Thevenin equivalent circuit looking out of the base of Q1

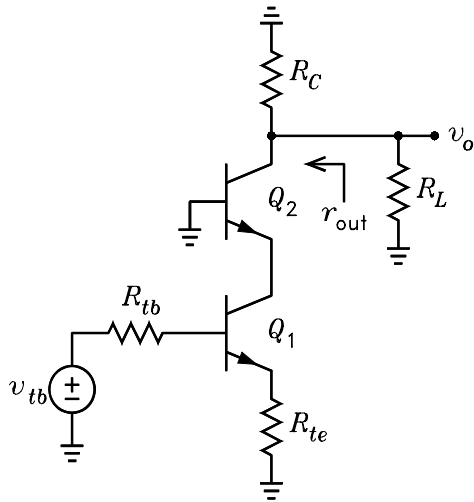

$$v_{tb1} := v_s \frac{R_P(R_2, R_3)}{R_S + R_P(R_2, R_3)}$$

$$v_{tb1} = 0.9777$$

$$R_{tb1} := R_P(R_S, R_P(R_2, R_3))$$

$$R_{tb1} = 977.6536$$

$$R_{te1} := R_P(R_E, R_4) \quad R_{te1} = 97.7273$$

$$r'_{e1} := \frac{R_{tb1} + r_x}{1 + \beta} + r_{e1} \quad r'_{e1} = 28.6805$$

$$r'_{e2} := \frac{r_x}{1 + \beta} + r_{e2} \quad r'_{e2} = 23.9113$$

Next make a Thevenin equivalent circuit looking out of the emitter of Q2

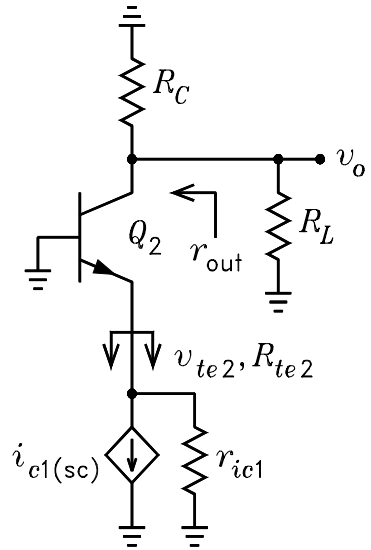

$$r_{ic1} := \frac{r_0 + R_P(r'_{e1}, R_{te1})}{1 - \frac{\alpha \cdot R_{te1}}{r'_{e1} + R_{te1}}} \quad r_{ic1} = 2.1678 \cdot 10^5$$

$$G_{mb1} := \frac{\alpha}{r'_{e1} + R_{te1}} \cdot \frac{r_0 - \frac{R_{te1}}{\beta}}{r_0 + R_P(r'_{e1}, R_{te1})}$$

$$i_{c1sc} := v_{tb1} \cdot G_{mb1} \quad i_{c1sc} = 7.692 \cdot 10^{-3}$$

$$v_{te2} := -i_{c1sc} \cdot r_{ic1} \quad v_{te2} = -1.6674 \cdot 10^3$$

$$R_{te2} := r_{ic1} \quad R_{te2} = 2.1678 \cdot 10^5$$

Now make a Norton equivalent circuit looking into the collector of Q1. It follows that the circuit for the output voltage and output resistance is

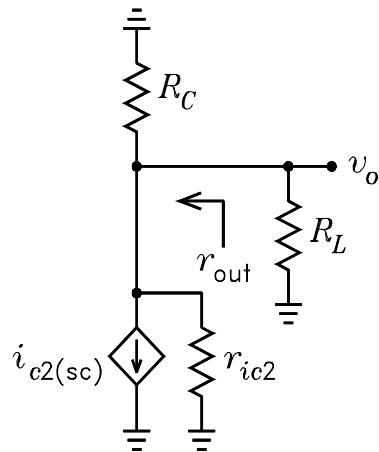

$$R_{tc2} := R_P(R_C, R_L) \quad R_{tc2} = 6.6667 \cdot 10^3$$

$$G_{me2} := \frac{\alpha}{r'_{e2} + R_{tc2}} \cdot \frac{r_0 + \frac{r'_{e2}}{\alpha}}{r_0 + R_P(r'_{e2}, R_{tc2})}$$

$$i_{c2sc} := -G_{me2} \cdot v_{te2} \quad i_{c2sc} = 7.6527 \cdot 10^{-3}$$

$$r_{ic2} := \frac{r_0 + R_P(r'_{e2}, R_{tc2})}{1 - \frac{\alpha \cdot R_{tc2}}{r'_{e2} + R_{tc2}}} \quad r_{ic2} = 9.7899 \cdot 10^6$$

$$v_o := -i_{c2sc} \cdot R_P(r_{ic2}, R_{tc2})$$

$$A_v := v_o \quad A_v = -50.9832 \quad \text{This is the voltage gain.}$$

$$r_{out} := R_P(R_C, r_{ic2}) \quad r_{out} = 1.9959 \cdot 10^4$$

The circuit for the input resistance is

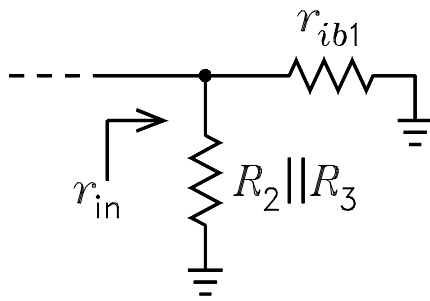

$$r_{ie2} := r'_{e2} \cdot \frac{r_0 + R_{tc2}}{r'_{e2} + r_0 + \frac{R_{tc2}}{1 + \beta}} \quad r_{ie2} = 27.0685$$

$$R_{tc1} := r_{ie2} \quad R_{tc1} = 27.0685$$

$$r_{ib1} := r_x + (1 + \beta) \cdot (r_{e1} + R_P(R_{te1}, r_0 + R_{tc1})) - \frac{\beta \cdot R_{te1} \cdot R_{tc1}}{R_{tc1} + r_0 + R_{te1}}$$

$$r_{ib1} = 2.4255 \cdot 10^4$$

$$r_{in} := R_P(r_{ib1}, R_P(R_2, R_3)) \quad r_{in} = 1.5604 \cdot 10^4$$

The following simpler solution is based on the r_o approximations for Q2 .

$$i_{c2sc} := \alpha \cdot i_{c1sc} \cdot \frac{r_{ic1}}{r_{ie2} + r_{ic1}} \quad i_{c2sc} = 7.6526 \cdot 10^{-3} \quad \text{The } \frac{r_{ic1}}{r_{ie2} + r_{ic1}} \text{ is a current divider.}$$

$$v_o := -i_{c2sc} \cdot R_P(r_{tc2}, r_{ic2})$$

$$A_v := v_o$$

$$A_v = -50.9823$$

This is the voltage gain.

$$r_{out} := R_P(r_{ic2}, R_C)$$

$$r_{out} = 1.9959 \cdot 10^4$$

$$r_{ib1} := r_x + (1 + \beta) \cdot (r_{e1} + R_{te1}) \quad r_{ib1} = 2.4304 \cdot 10^4$$

$$r_{in} := R_P(r_{ib1}, R_P(R_2, R_3)) \quad r_{in} = 1.5624 \cdot 10^4$$