

GEORGIA INSTITUTE OF TECHNOLOGY
School of Electrical and Computer Engineering

Course ECE 2040
Circuit Analysis

November 27, 2000

Problem Set #13–Solutions

Problem 13.1:

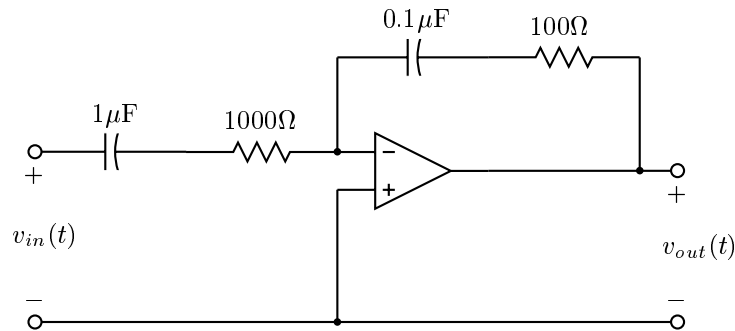

Plot the asymptotic Bode plot for the magnitude of the frequency response of the above circuit

Solution:

$$H(s) = -\frac{100 + \frac{1}{10^{-7}s}}{1000 + \frac{1}{10^{-6}s}}$$

$$= -\frac{1}{10} \cdot \frac{s + 10^5}{s + 10^3}$$

$$H(j\omega) = \frac{1}{10} \cdot \frac{j\omega + 10^5}{j\omega + 10^3} = -10 \frac{1 + j10^{-5}\omega}{1 + j10^{-3}\omega}$$

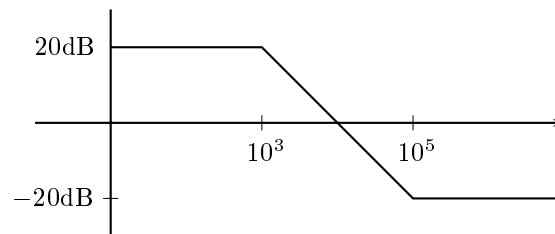

Problem 13.2: Sketch Bode magnitude and phase plots for the following system functions

(a) $H(s) = \frac{1}{s+10}$

(b) $H(s) = 1 - 10s$

(c) $H(s) = \frac{s-20}{s+200}$

Solution:

(a) For this the gain is 0.1 (= -20 dB) for low frequencies and rolls off at 20 dB/decade for high frequencies.

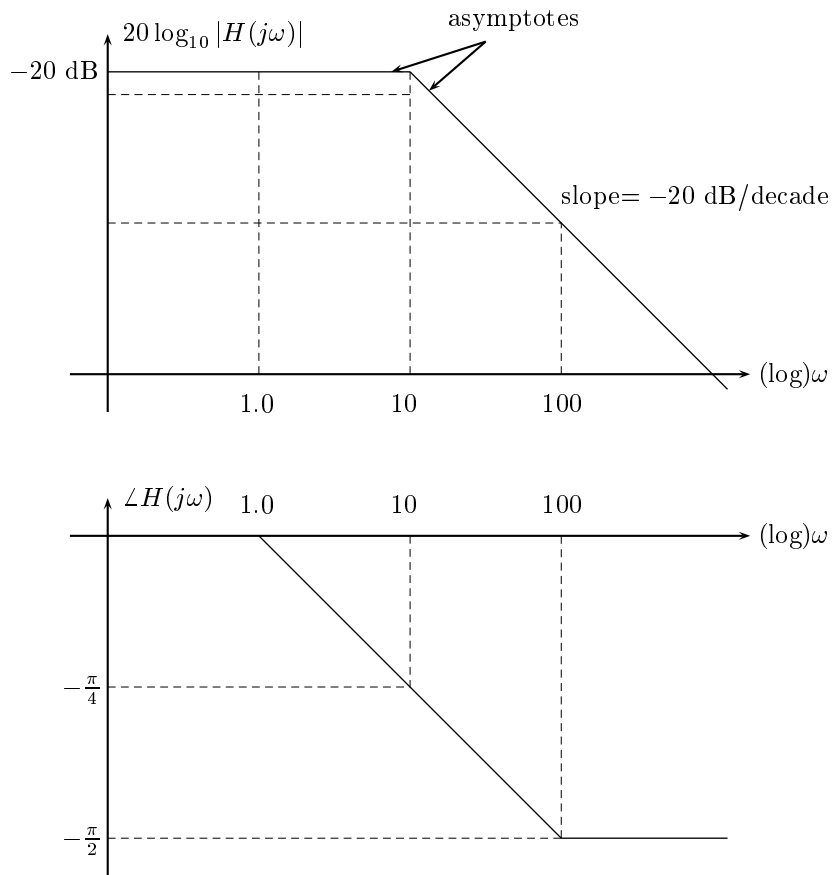

(b) Here the break frequency is 0.1 rad/s and for low frequencies the magnitude gain is 0 dB. The phase is zero at low frequencies and $-\frac{\pi}{2}$ for high ones.

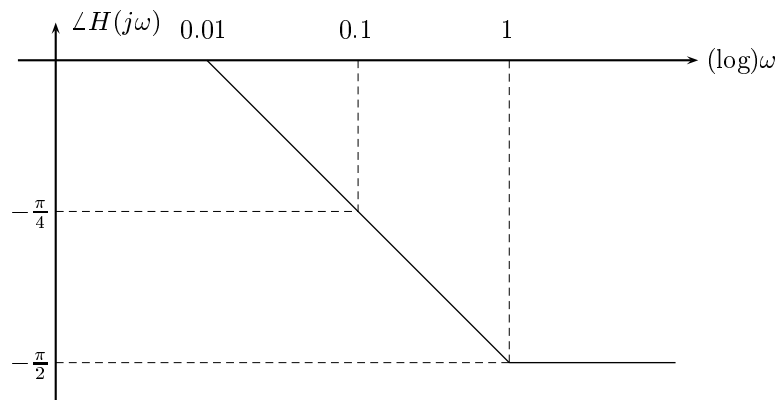
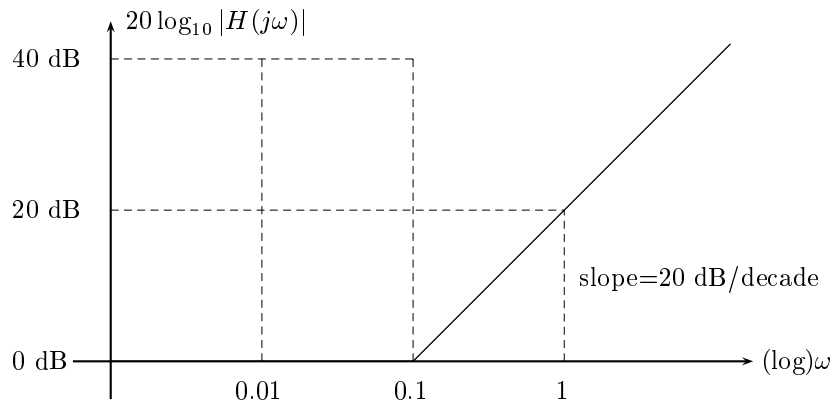

- (c) At frequencies below 20 the gain is constant at 0.1 (= -20 dB). At frequencies above 200 it is constant at 1.0. The phase is $-\pi$ at low frequencies and 0 at high ones.

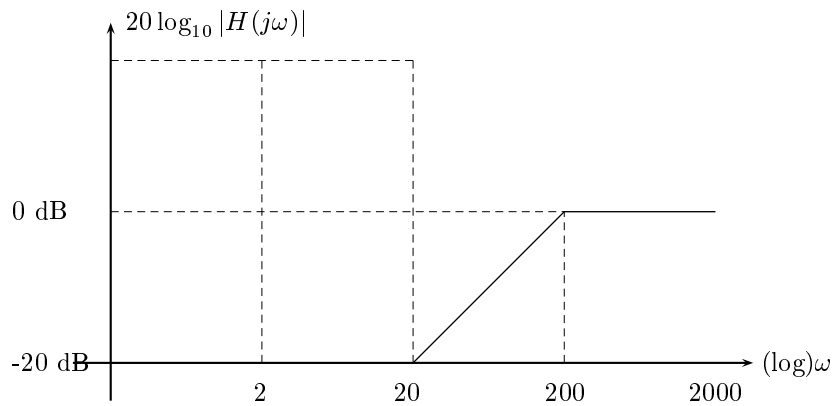

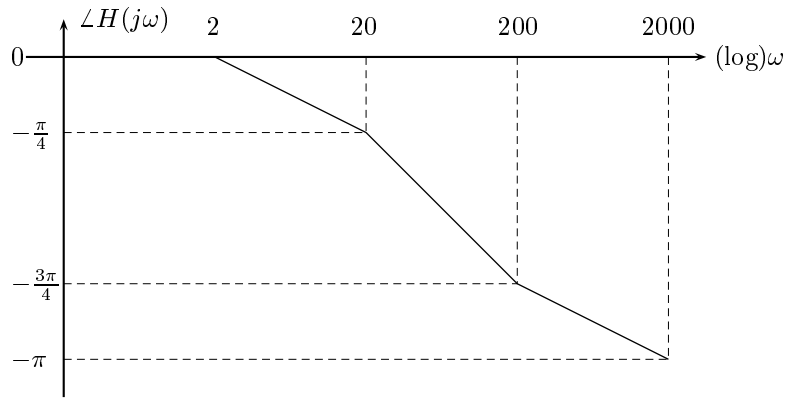

Problem 13.3: A circuit with the system function

$$H(s) = \frac{ks}{(s+a)(s+b)}$$

has the Bode magnitude plot shown below.

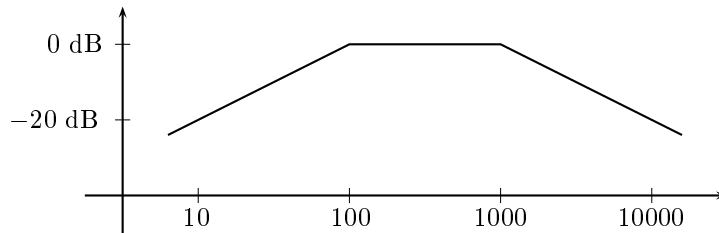

Determine the values of k , a , and b .

Solution: This system function consists of four components: a constant term, a zero at the origin, and two real poles. The Bode magnitude plot is, therefore, the sum of four components. The zero at the origin accounts for the low frequency increase in the frequency response. The change in the slope from 20 dB/decade to 0 dB/decade is caused by a pole at 100 rad/second. The second change in slope from 0 dB/decade to -20 dB/decade is caused by the other. Therefore

$$\begin{aligned} a &= 100 \\ b &= 1000 \text{ or vice versa.} \end{aligned}$$

To determine the gain, we know that the gain at 100 radians/second is approximately -6db.

$$|H(j100)| = \frac{1}{\sqrt{2}} = \frac{k100}{|j100 + 100| \cdot |j100 + 1000|}$$

Therefore,

$$k = 1000.$$

Problem 13.4:

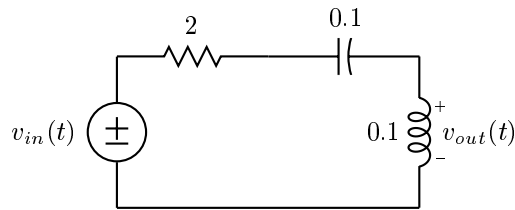

- (a) Calculate the system function of the above circuit.
- (b) Draw the Bode magnitude plot for the circuit.

Solution:

(a)

$$H(s) = \frac{Ls}{Ls + R + \frac{1}{Cs}} = \frac{LCs^2}{LCs^2 + RCs + 1} = \frac{s^2}{s^2 + \frac{R}{L}s + \frac{1}{LC}} = \frac{s^2}{s^2 + 20s + 100}$$

(b)

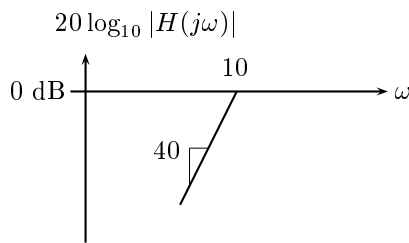

Problem 13.5: The Bode magnitude plot for a circuit is shown below. We are told that all of the poles of the system and all of its zeros have negative real parts (i.e., they lie in the left-half of the s -plane). Determine the system function of the circuit.

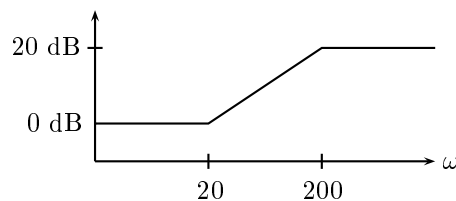

Solution: Since the Bode asymptotes break up at 20 rad/sec with a slope of 20 dB/decade, the system has a real zero at $s = -20$. At $\omega = 200$ the Bode plot has a second break point which reduces the slope by 20 dB/decade. Thus the system also has a real pole at $s = -200$.

$$H(s) = \frac{10(s + 20)}{s + 200}$$

The constant gain is necessary to give the circuit a gain at DC of 1 (=0dB).
