

GEORGIA INSTITUTE OF TECHNOLOGY
School of Electrical and Computer Engineering

Course ECE 2040

Circuit Analysis

Assigned: September 1, 2000

Due: September 8, 2000

Problem Set #2

Reading: Read the following sections from the class notes:

Chapter 1, Sections 1.4.4, 1.5

Chapter 2, Sections 2.1.1–2.1.3

Appendix A, All sections

Reading: Read the following sections from Dorf and Svoboda:

Chapter 2, Section 2.8; (definitions of dependent sources)

Announcement: The first quiz will be held during the class hour on Wednesday, September 13, 2000. It will be a closed book test, although calculators are permitted (but probably not necessary). It will cover the same material that is covered in Problem Sets 1 and 2.

Problem 2.1: Find the current $i_1(t)$ for the circuit shown in Figure 1.

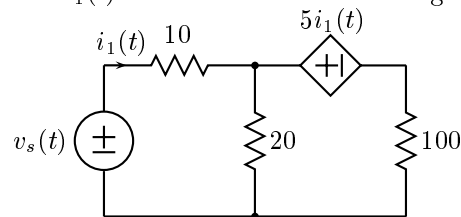

Figure 1: Circuit for Problem 2.1.

Problem 2.2: Determine the voltage $v(t)$ in the circuit in Figure 2.

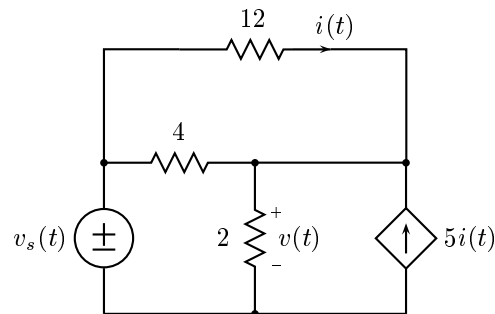

Figure 2: Figure for Problem 2.2.

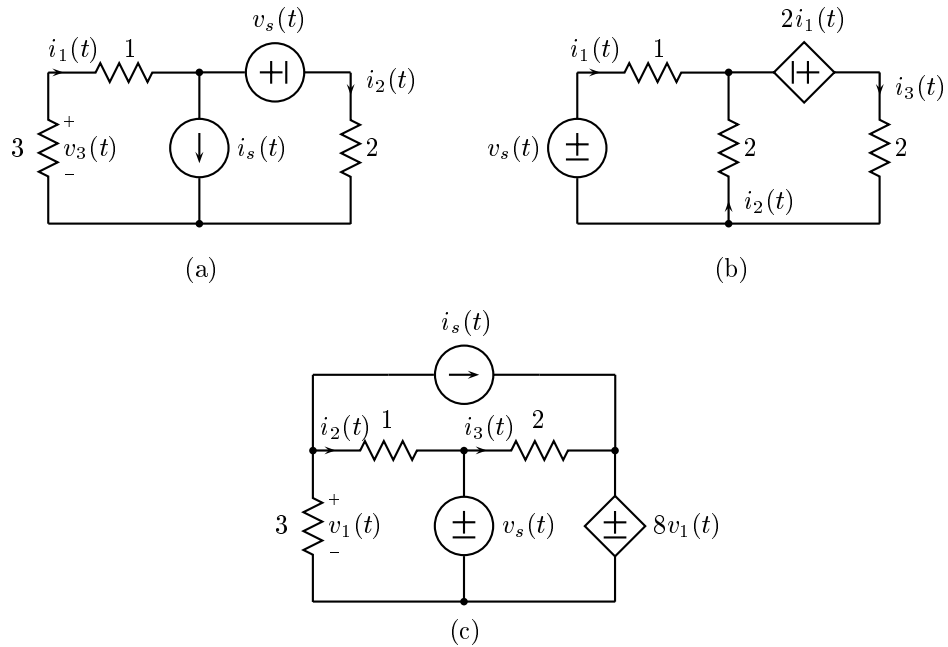

Figure 3: Networks for Problem 2.3.

Problem 2.3: This problem is concerned with the three networks shown in Figure 3.

- (a) For the network in (a)
 - (i.) Draw the basic network.
 - (ii.) Identify the closed paths in the original network that correspond to meshes in the basic network.
 - (iii.) Identify the closed surfaces in the original network that correspond to nodes in the basic network.
- (b) Repeat for the network in (b).
- (c) Repeat for the network in (c).

Problem 2.4: For each of the networks in Problem 2.3 above, write the complete set of linear equations that defines the equilibrium using the basic networks that you found. Put these equations in matrix-vector form and solve them for the indicated variables using MATLAB.

Problem 2.5: Solve for $i(t)$ in the circuit below.

