

EE4601

Communication Systems

Lecture 23

Noncoherent Detection

Noncoherent Detection

With noncoherent detection, the carrier phase is not recovered at the receiver. Information is transmitted in amplitude and frequency only, not in the phase of the carrier.

Transmit:

$$s_i(t) = \sqrt{\frac{2E}{T}} \cos(2\pi f_c t) \quad 0 \leq t \leq T$$

Receive:

$$r(t) = \sqrt{\frac{2E}{T}} \cos(2\pi f_c t + \Phi) + n(t)$$

Assume: Φ is a random variable with *pdf*

$$f_{\Phi}(\phi) = \begin{cases} \frac{1}{2\pi} & -\pi \leq \phi \leq \pi \\ 0 & \text{else} \end{cases}$$

Noncoherent Detection

Note that f_c is usually very large.

$$c = f_c \lambda_c \rightarrow \lambda_c = \frac{c}{f_c}$$

At 1 GHz, $\lambda_c \approx 0.3$ m

Therefore, a change in radio path length of 30 cm causes a 2π change in carrier phase.

A vehicle (aircraft) travelling 1000 km/h will travel 278 m/s and experience a carrier phase change of $278/0.3 \times 2\pi = 1853\pi$ rad/s.

Rather than try and track this rapidly varying carrier phase, we may use a non-coherent receiver that does not require the carrier phase.

Square-Law Correlation Detector

$$r(t) = \sqrt{\frac{2E}{T}} \cos \Phi \cos(2\pi f_c t) - \sqrt{\frac{2E}{T}} \sin \Phi \sin(2\pi f_c t) + n(t)$$

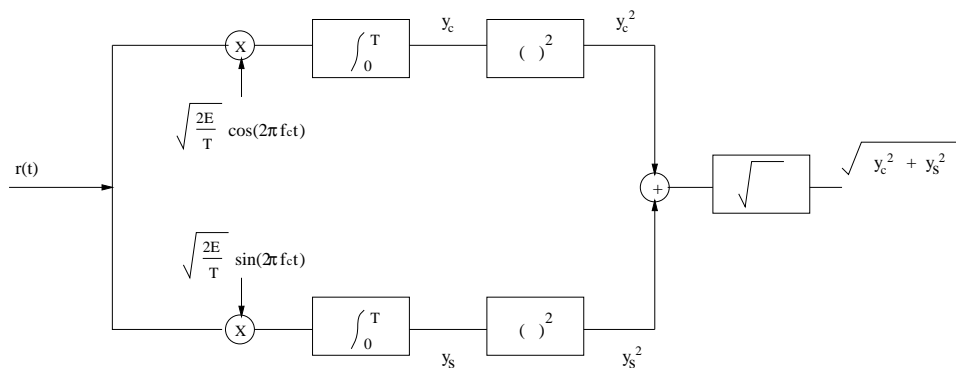

In the absence of noise $n(t)$,

$$y_c = \sqrt{E} \cos \Phi, \quad y_s = \sqrt{E} \sin \Phi$$

$$y_c^2 + y_s^2 = E \quad \text{the energy in the waveform}$$

The above receiver is called a *square-law correlation detector*.

Noncoherent BFSK

Information can only be transmitted in amplitude and frequency. Consider BFSK waveforms where

$$s_1(t) = \sqrt{\frac{2E}{T}} \cos(2\pi f_c t)$$
$$s_2(t) = \sqrt{\frac{2E}{T}} \cos(2\pi(f_c + \Delta f)t)$$

Suppose these waveforms are transmitted on an ideal channel with a propagation delay t_d . Then the noiseless received waveforms are

$$s_1(t) = \sqrt{\frac{2E}{T}} \cos(2\pi f_c(t - t_d)) = \sqrt{\frac{2E}{T}} \cos(2\pi f_c t + \Phi_1)$$
$$s_2(t) = \sqrt{\frac{2E}{T}} \cos(2\pi(f_c + \Delta f)t - 2\pi(f_c + \Delta f)t_d) = \sqrt{\frac{2E}{T}} \cos(2\pi(f_c + \Delta f)t + \Phi_2)$$

where $\Phi_1 = -2\pi f_c t_d$ and $\Phi_2 = -2\pi(f_c + \Delta f)t_d$. If we choose $\Delta f = \frac{1}{T}$, then received waveforms $s_1(t)$ and $s_2(t)$ are orthogonal regardless of Φ_1 and Φ_2 .

Noncoherent BFSK

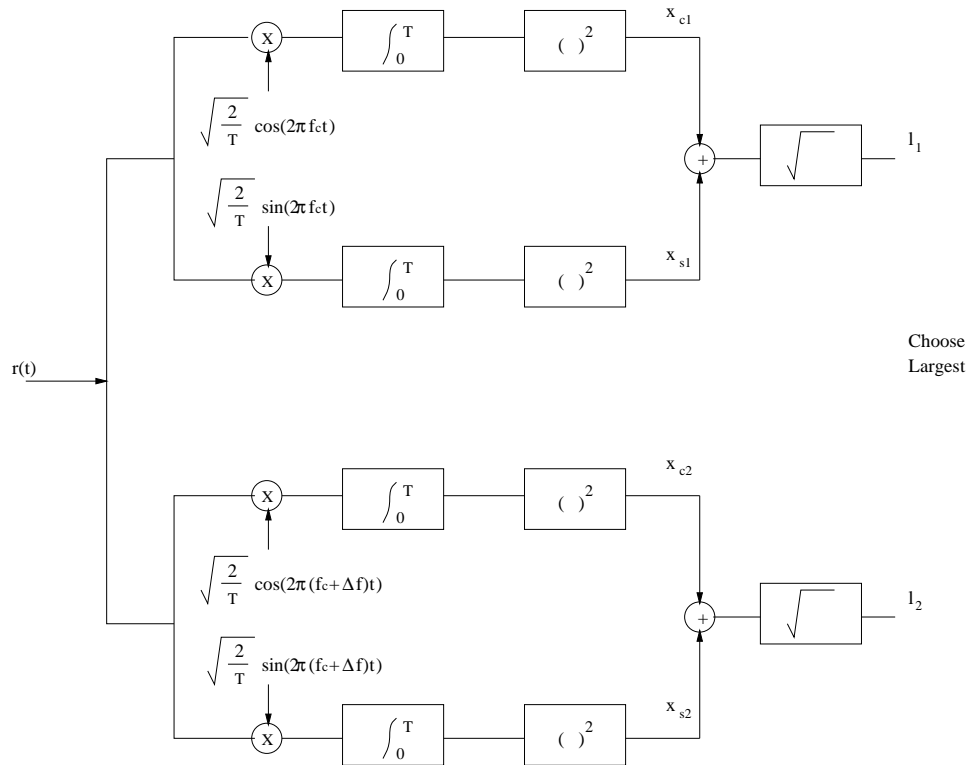

Error Probability of Noncoherent BFSK

Assume $s_1(t)$ was sent. The probability of bit error is

$$P_b = P(l_2 > l_1)$$

To find P_b , we need the conditional pdfs of l_1 and l_2 given that $s_1(t)$ was sent.

$$\begin{aligned}x_{c1} &= \int_0^T r(t) \sqrt{\frac{2}{T}} \cos(2\pi f_c t) dt \\ &= \int_0^T \left(\sqrt{\frac{2E}{T}} \cos(2\pi f_c t + \Phi_1) + n(t) \right) \sqrt{\frac{2}{T}} \cos(2\pi f_c t) dt \\ &= \sqrt{E} \cos \Phi_1 + n_{c1}\end{aligned}$$

Error Probability of Noncoherent BFSK

$$\begin{aligned}x_{s1} &= \int_0^T r(t) \sqrt{\frac{2}{T}} \sin(2\pi f_c t) dt \\&= \int_0^T \left(\sqrt{\frac{2E}{T}} \cos(2\pi f_c t + \Phi_1) + n(t) \right) \sqrt{\frac{2}{T}} \sin(2\pi f_c t) dt \\&= \sqrt{E} \sin \Phi_1 + n_{s1}\end{aligned}$$

The detector output is

$$l_1 = \sqrt{x_{c1}^2 + x_{s1}^2}$$

Error Probability of Noncoherent BFSK

Likewise,

$$\begin{aligned}x_{c2} &= \int_0^T \left(\sqrt{\frac{2E}{T}} \cos(2\pi f_c t + \Phi_1) + n(t) \right) \sqrt{\frac{2}{T}} \cos(2\pi(f_c + \Delta_f)t) dt \\ &= n_{c2} \\ x_{s2} &= \int_0^T \left(\sqrt{\frac{2E}{T}} \cos(2\pi f_c t + \Phi_1) + n(t) \right) \sqrt{\frac{2}{T}} \sin(2\pi(f_c + \Delta_f)t) dt \\ &= n_{s2}\end{aligned}$$

The first term in each integral is zero because $s_1(t)$ and $s_2(t)$ are orthogonal for any Φ_1 and Φ_2 .

The detector output is

$$l_2 = \sqrt{x_{c2}^2 + x_{s2}^2} = \sqrt{n_{c2}^2 + n_{s2}^2}$$

Error Probability of Noncoherent BFSK

$$n_{c1} = \int_0^T n(t) \sqrt{\frac{2}{T}} \cos(2\pi f_c t) dt$$
$$n_{s1} = \int_0^T n(t) \sqrt{\frac{2}{T}} \sin(2\pi f_c t) dt$$

n_{c1} and n_{s1} are Gaussian random variables with

$$E[n_{c1}] = E[n_{s1}] = 0, \quad \sigma_{n_{c1}}^2 = \sigma_{n_{s1}}^2 = \frac{N_0}{2}, \quad E[n_{c1}n_{s1}] = 0$$

The fact that that $E[n_{c1}n_{s1}] = 0$ follows from the property

$$\frac{2}{T} \int_0^T \cos(2\pi f_c t) \sin(2\pi f_c t) dt = 0$$

for $f_c T \gg 1$.

Error Probability of Noncoherent BFSK

Likewise

$$n_{c2} = \int_0^T n(t) \sqrt{\frac{2}{T}} \cos(2\pi(f_c + \Delta_f)t) dt$$
$$n_{s2} = \int_0^T n(t) \sqrt{\frac{2}{T}} \sin(2\pi(f_c + \Delta_f)t) dt$$

n_{c2} and n_{s2} are Gaussian random variables with

$$E[n_{c2}] = E[n_{s2}] = 0, \sigma_{n_{c2}}^2 = \sigma_{n_{s2}}^2 = \frac{N_0}{2}, E[n_{c2}n_{s2}] = 0$$

Since $s_1(t)$ and $s_2(t)$ are orthogonal, it also follows that

$$E[n_{c1}n_{c2}] = 0, E[n_{c1}n_{s2}] = 0, E[n_{s1}n_{c2}] = 0, E[n_{s1}n_{s2}] = 0$$

Hence, n_{c1} , n_{s1} , n_{c2} , n_{s2} are i.i.d. Gaussian $\sim N(0, N_0/2)$.