

A Resonant Technique to Measure the Dielectric Properties of Planar Materials

William R. Humbert* and Waymond R. Scott, Jr.

School of Electrical and Computer Engineering

Georgia Institute of Technology

Atlanta, GA 30332-0250

Abstract - A previously introduced resonant measurement technique is extended to include dielectric sheets. The technique is not limited by the sheet's thickness or dielectric constant because it involves a full-wave analysis of the fixture. A method to account for conduction loss due to the surface resistance of the metal walls of the fixture is presented. Experimental results are presented and compared to previously reported values and are in excellent agreement.

Introduction

The increasing use of low-loss dielectric materials demands the ability to accurately measure their electrical properties. Resonant measurement techniques are often employed in cases where high accuracy is required for low-loss materials. The authors previously introduced a new resonant technique for measuring cylindrical dielectric rods [1]. The presented work is a demonstration of the capability of the technique to accurately determine the permittivity and loss tangent of various dielectric sheets. In [2], a similar resonant fixture is used to determine the electrical properties of dielectric sheets. However, the technique is limited to thin dielectric films with relatively low dielectric constants because of a perturbational method that is applied in the analysis. Use of the present technique involves a full-wave analysis of the fixture, and thus is not limited by the dielectric sample's thickness or dielectric constant.

The fixture used is rotationally symmetric and is shown in Figure 1 in the $\rho - z$ plane. It consists of two rotationally symmetric metallic plates placed opposing each other, where each plate has a central opening leading to an extended circular section. The fixture has circular and radial waveguide sections with dimensions denoted by subscripts c and r respectively. The radial waveguide section contains the dielectric sheet while the circular waveguide section is air-filled and provides access for coupling to the resonator. At the junction of these waveguide regions is the core of the resonator. With properly chosen dimensions, h_r and D_c , the resonant mode will be confined in the region near the core of the resonator and produce exponentially decaying fields in the circular and radial waveguide regions; consequently, h_c and D_r can be chosen to be finite sizes.

A perturbational analysis is used with the edge-based finite-element method to model the fixture. The fields of the lossy resonator are approximated by those of a loss-less resonator. With the measured resonant frequency, a root-finding technique is used with the finite-element method to determine the permittivity. In doing so, the electromagnetic fields are also calculated. With the measured quality factor, the calculated fields are used to determine the loss tangent.

Analysis

The TE_{011} mode is used to reduce measurement errors associated with air gaps at

William R. Humbert is supported by the Electromagnetics and Reliability Directorate at Rome Laboratory, Hanscom AFB, MA.

dielectric-conductor interfaces. The TE_{011} mode does not have an \vec{E} -field component normal to the air gaps; therefore, measurements made using this mode are not strongly affected by possible air gaps.

In and near the resonator core, the field distributions are complicated due to the complex geometry, and thus, no closed form expression for the field exists. However, sufficiently far from the resonator core, the field distributions are essentially due to a single waveguide mode in the circular and radial waveguide regions. In the upper circular waveguide region, the field is essentially the TE_{01} circular waveguide mode. The mode is ϕ -independent, has one variation in the ρ direction, and has the z dependence $e^{-k_z z}$. For resonance to occur, the fields must decay, therefore, k_z must be positive. In the radial waveguide region, the field is essentially the TE_{01} radial waveguide mode. It is ϕ -independent, has one variation in the z direction, and has the ρ dependence $K_0(k_\rho \rho)$. Again, for resonance to occur the fields must decay, and thus, k_ρ must be positive.

Figure 2 is a diagram illustrating all possible operating points for the TE_{011} mode. The operating boundaries are set by the cut-off conditions in the circular and radial waveguide regions, $k_z D_c = 0$ and $k_\rho D_c = 0$ respectively. For example, for $\epsilon'_{rm} = 3$, the TE_{011} mode will only resonate when h_r/D_c is between 0.01 and 0.46. The TE_{011} mode will not resonate for any point outside the $k_z D_c = 0$ and $k_\rho D_c = 0$ curves. Points outside of these boundaries correspond to complex wave numbers which yields propagating waves and prevents resonance. Curves at which $k_z D_c$ and $k_\rho D_c = 1, 2,$ and 4 are also included. This allows the rates of decay in each of the waveguide regions to be determined at particular operating points. For example, with $\epsilon'_{rm} = 10$ and $h_r/D_c = 0.021$, the mode will resonate with decay rates $k_z D_c \approx 4$ and $k_\rho D_c \gg 4$.

Experimental Results

At resonance and with the measurement fixture empty (air-filled), the dielectric loss is insignificant. Therefore, the measured quality factor is approximately equal to the quality factor due to the conduction loss. In this case, the resonant frequency and quality factor were measured and used to determine the permittivity of air and the surface resistance of the metal walls. In Table I, the relative permittivity and

TABLE I
MEASURED PERMITTIVITY FOR AIR AND SURFACE RESISTANCE FOR ALUMINUM PLATES.

h_r/D_c	f_0 (GHz)	Q_c	ϵ'_{ra}	$R_s/\sqrt{f_0}$ ($\times 10^{-7}$)
0.400	17.704	7000	1.00039	5.4

the surface resistance are presented. The measured value of the permittivity of air compares well to the known value of air at atmospheric pressure, room temperature, and 50 % humidity, $\epsilon'_{ra} = 1.00064$. The measured value of the surface resistance is within the range of expected values for aluminum and will be used when calculating the loss tangent in subsequent measurements.

The resonant frequency and the loaded quality factor were measured for several dielectric sheets. The results are displayed in Table II along with previously reported values and their sources. Once again, the measurement technique produces excellent

results in determining the permittivity of the various materials. The measured values for the loss tangent are also in very good agreement with the reported values. The lower limit on the measurable loss tangent is set by the conduction loss in the fixture. For the polycrystalline Al_2O_3 sample, very good results were obtained for the loss tangent even though the conduction loss was more than 10 times that of the dielectric loss ($Q_c = 10, 700, Q_d = 160, 000$).

TABLE II
MEASURED PERMITTIVITY AND LOSS TANGENT FOR VARIOUS DIELECTRIC SHEETS.

Mat.	Presented Work				Previously Reported		
	h_r/D_c	f_0 (GHz)	ϵ'_{rm}	$\tan\delta_m$ ($\times 10^{-5}$)	ϵ'_{rm}	$\tan\delta_m$ ($\times 10^{-5}$)	Src.
TEF.	0.083	18.239	2.06	44	2.05-2.08	20-37	[3],[4]
TEF.	0.172	16.613	2.06	30	2.05-2.08	20-37	[3],[4]
TEF.	0.251	15.252	2.07	20	2.05-2.08	20-37	[3],[4]
ALM.	0.040	14.143	9.49	10	9.39-9.80	9-10	Manf., [5]
ALM.	0.081	11.266	9.58	10	9.39-9.80	9-10	Manf., [5]
ALM.	0.121	9.830	9.55	12	9.39-9.80	9-10	Manf., [5]
FSD. SIL.	0.073	16.230	3.83	22	3.83	20	[6]
LSAT	0.027	11.633	4580	1.6	22.8	1.0	[7]
LaAlO_3	0.014	14.065	23.72	3.7	23.7	2.0	[7]
LaAlO_3	0.027	11.421	23.90	2.4	23.7	2.0	[7]
LaAlO_3	0.041	9.694	23.81	2.2	23.7	2.0	[7]
Al_2O_3	0.015	17.501	9.41	2.0	9.37	2.0	Manf. [7]
Al_2O_3	0.017	17.173	9.36	1.8	9.37	2.0	Manf., [7]
Al_2O_3	0.032	15.054	9.33	1.7	9.37	2.0	Manf., [7]

References

- [1] William R. Humbert and Waymond R. Scott Jr. A New Technique for Measuring the Permittivity and Loss tangent of Cylindrical Dielectric Rods. *IEEE Microwave Guided Wave Lett.*, vol. 6:262-264, July 1996.
- [2] Godon Kent. Dielectric Resonances for Measuring Dielectric Properties. *Microwave Journal*, pages 99-114, October 1988.
- [3] R. J. Cook. Microwave Cavity Methods. In *High Frequency Dielectric Measurement*, pages 12-27, Teddington, UK, March 1972. National Physics Laboratory.
- [4] Arthur von Hippel, editor. *Dielectric Materials and Applications*. Artech House, 1954.
- [5] Reinmut K. Hoffman, editor. *Handbook of Microwave Integrated Circuits*. Artech House, Inc., 1987.
- [6] William E. Courtney. Analysis and Evaluation of a Method of Measuring the Complex Permittivity and Permeability of Microwave Insulators. *IEEE Trans. Microwave Theory Tech.*, MTT-18:476-485, August 1970.
- [7] Claudio Zuccaro et al. Materials for HTS-shielded Dielectric Resonators. To be published: *IEEE Trans. App. Superconductivity*, June 1997.

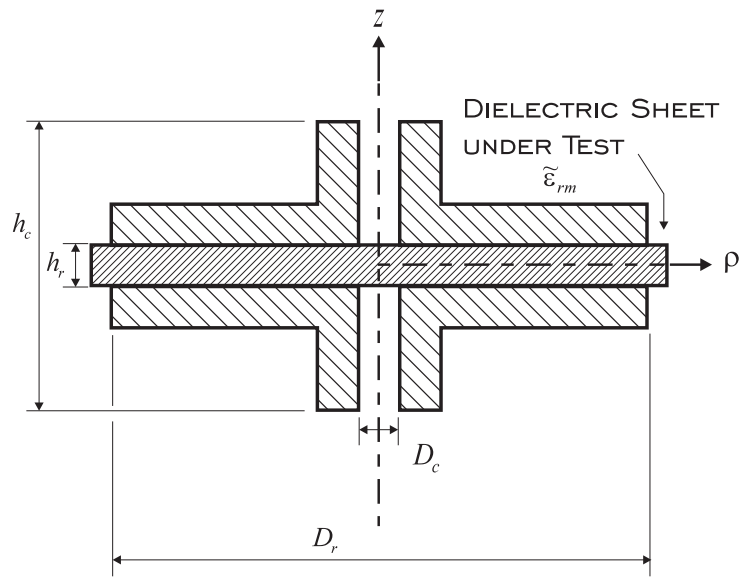

Figure 1. Diagram of device used for measuring dielectric sheets.

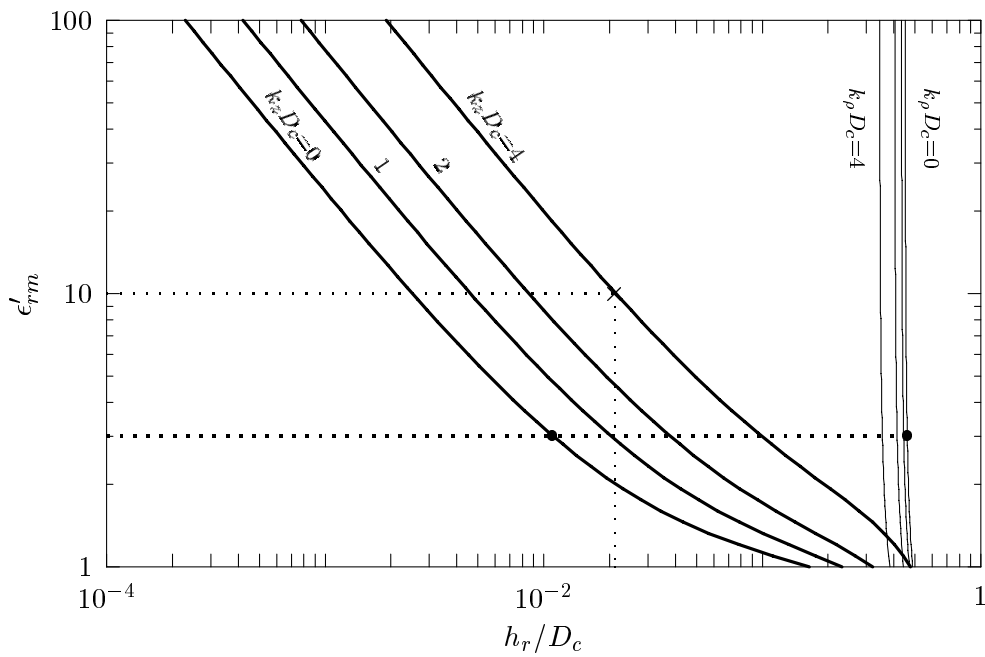

Figure 2. Diagram depicting valid operating regions of the TE_{011} mode